

道依茨**226B**系列发电机组用柴油机零件图册

PARTS CATALOGUE FOR DEUTZ 226B SERIES GENERATING DIESEL ENGINE

前 言

为使 226B 系列发电机组用柴油机在使用、维护等工作上的方便特汇编本图册，以供用户在使用中查阅参考，本图册汇编了四种柴油机，其它机型亦可参考。

图册基本上按零件的相互位置关系绘制而成，明细栏中有零件件号，件数、适用的柴油机设计号、标准件的规格标准、中文名称、英文名称。

随着技术的不断提高，本图册的内容将有所变化，不再另行通知，特请用户注意。

FOREWORD

This parts catalogue is specially prepared for customers to facilitate the use of 226B series diesel engine in operation and maintenance. It only includes the main models manufactured in the works at present, with regard to other models, the customers may refer to it.

The illustrations are grouped under the heading of each assembly and numbered individually part No., Quantity, Model, English designation, and so on are written in the parts list.

With the development of technical and production, the catalogue will be revised. Please pay attention to our revised edition.

目 录 CONTENTS

01-----机体总成一 -----.1 CRANKCASE ASSEMBLY(一)	08-----气缸盖总成-----29 COYLINDER HEAD ASSEMBLY	17-----13020109 高压油管总成-----55 HIGH PRESSURE PIPE ASSEMBLY
01-----机体总成二-----4 CRANKCASE ASSEMBLY (二)	09-----凸轮轴总成-----32 CAMSHAFT ASSEMBLY	17-----13020107 高压油管总成-----56 HIGH PRESSURE PIPE ASSEMBLY
01-----机体总成三-----6 CRANKCASE ASSEMBLY(三)	10-----摇臂座总成-----34 ROCKER ARM BRACKET ASSEMBLY	13020106
01-----机体总成四-----8 CRANKCASE ASSEMBLY(四)	11-----机油泵总成-----36 OIL PUMP ASSEMBLY	17 -----13020088 高压油管总成-----57 HIGH PRESSURE PIPE ASSEMBLY
01-----13020109 机体总成五-----10 CRANKCASE ASSEMBLY(五)	12-----润滑油进油管总成-----38 LUBRICATING OIL LINE ASSEMBLY	18-----13020109 中间垫块总成-----59 ADAPTER ASSEMBLY
13020107	13-----13020109 润滑油管总成一-----41 OIL SUCTION LINE ASSEMBLY(一)	13020107
01-----13020106 机体总成五-----12 13020088	13-----13020107 润滑油管总成一-----42 OIL SUCTION LINE ASSEMBLY(一)	18-----13020106 中间垫块总成-----60 13020088
CRANKCASE ASSEMBLY(五)	13-----13020088 润滑油管总成一 -----43 OIL SUCTION LINE ASSEMBLY(一)	ADAPTER ASSEMBLY
01-----机体总成六-----14 CRANKCASE ASSEMBLY(六)	13-----润滑油管总成二-----45 OIL SUCTION LINE ASSEMBLY(二)	19-----13020109 进、排气系统一-----63 AIR INTAKE EXHAUST SYSTEM(一)
02-----油底壳总成-----16 OLL PAN ASSEMBLY	14-----高压油泵总成-----47 FUEL INJECTION PUMP ASSEMBLY	19-----13020109 进、排气系统二-----65 AIR INTAKE EXHAUST SYSTEM(二)
03-----曲轴总成-----18 CRANKSHAFT ASSEMBLY	15-----喷油器总成-----49 FUEL INJECTOR ASSEMBLY	19-----13020107 进、排气系统总成-----67 AIR INTAKE EXHAUST SYSTEM ASSEMBLY
04-----二级平衡机构总成-----21 MASS BLANCER ASSEMBLY	16-----13020109 燃油滤清器总成-----51 FUEL FILTER ASSEMBLY	19-----13020106 进、排气系统总成-----70 AIR INTAKE EXHAUST SYSTEM ASSEMBLY
05-----连杆总成-----23 CONNECTING ROD ASSEMBLY	13020107	19-----13020088 进、排气系统总成-----71 AIR INTAKE EXHAUST SYSTEM ASSEMBLY
06-----活塞总成-----25 PISTON ASSEMBLY	16-----13020106 燃油滤清器总成-----53 13020088...	20-----13020109 空滤器总成-----74 AIR FILTER ASSEMBLY
07-----气缸盖罩总成-----27 CYLINDER HEAD COVER ASSEMBLY	FUEL FILTER ASSEMBLY	20-----13020107 空滤器总成-----76 AIR FILTER ASSEMBLY
		13020106

目 录 CONTENTS

20-----13020088 空滤器总成-----78	27-----发动机支架总成 -----103	
AIR FILTER ASSEMBLY	ENGINE BRACKET ASSEMBLY	
21----- 13020109 消音器总成-----80	28-----13020109 水箱总成-----105	
SILENCER ASSEMBLY	RADIATOR ASSEMBLY	
21-----13020107 消音器总成-----82	13020107	
SILENCER ASSEMBLY	28----- 13020106 水箱总成-----106	
21----- 13020106 消音器总成-----84	13020088	
SILENCER ASSEMBLY	RADIATOR ASSEMBLY	
21----- -13020088 消音器总成-----85	29-----燃油回油管总成-----108	
SILENCER ASSEMBLY	LEAK OFF LINE ASSEMBLY	
22-----冷却系统总成-----87	30-----防护罩总成-----110	
COOLING SYSTEM ASSEMBLY	SHEILD ASSEMBLY	
13020107		
22----- 13020106 冷却系统总成-----90		
13020088		
COOLING SYSTEM ASSEMBLY		
23-----飞轮壳总成-----93		
FLYWHEEL HOUSING ASSEMBLY		
24-----三角带总成-----95		
NARRON V-BELT ASSEMBLY		
25-----启动机总成-----97		
STARTER ASSEMBLY		
26-----13020109 发电机及支架总成-----99		
ALTERNATOR AND BRACKET ASSEMBLY		
13020107		
26-----13020106 发电机及支架总成----101		
13020088		
ALTERNATOR AND BRACKET ASSEMBLY		

机体总成一 CRANKCASE ASSEMBLY(一)

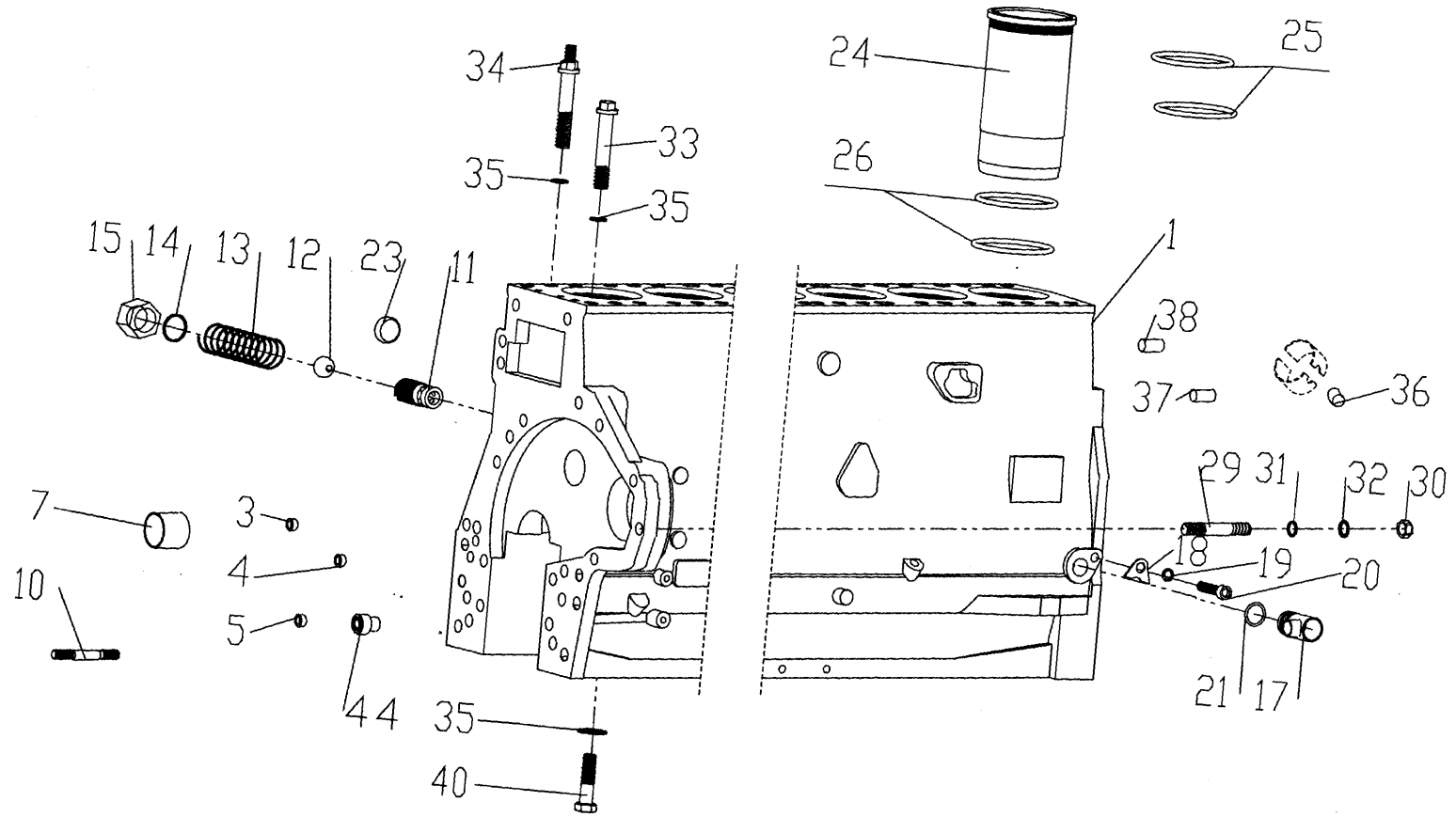

机体总成一 CRANKCASE ASSEMBLY(一)

序号 Pos.	图号 Teile. Number	组别 Sort	柴油机设计号 (件数) Engine SN Stk.				规格标准 DIN/Fremdfabr. Nr.	中文名称 Denomination	英文名称 Designation
			13020109	13020107	13020106	13020088			
1	13023112	01	1					机体组件	ENGINE BLOCK
1	13023132	01		1				机体组件	ENGINE BLOCK
1	12273329	01			1			机体组件	ENGINE BLOCK
1	12273346	01				1		机体组件	ENGINE BLOCK
3	12151365	08	10	8	6	6	290/s-8	塞子	PLUG
4	12273515	01	2	2	2	2	290/-12	塞子	PLUG
5	12273557	01	3	3	3	3	290/-13	塞子	PLUG
7	12159599	01	1	1	1	1		凸轮轴衬套	BEARING BUSH
10	01153348	01	1	1	1	1	M8 * 25 - 10.9 Zn DGB898	双头螺柱	STUD
11	12167053	01	1	1		1		螺杆	SCREW FITTING
12	01116958	01	1	1		1	9GB308	球	BALL
13	01221356	01	1	1		1		弹簧	COMPRESSINO SPRING
14	13023361	01	1	1		1	16JB982	组合密封垫圈	SEALINE RING
15	12167057	01	1	1		1		帽形螺母	ACORN NUT
17	12160117	01	1	1		1		焊接弯管	MANIFOLD
18	12160129	01	1	1		1		固定板	RETAINING PLATE
19	01177981	01	1	1		1	Q40308	弹簧垫圈	SPRING LOCK WASHER
20	01151498	01	1	1		1	M8 * 16 - 12.9 GB70	内六角圆柱头螺钉	CHEESE HEAD SCREW
21	01153869	01	1	1		1	20.3 * 24 H2927	O型密封圈	O-SEAL
23	01152717	01	5	3	2	2	50 DIN443	碗形塞	COVER
24	13024173	01	6	4	3	3		气缸套	CYLINDER LINER

机体总成一 CRANKCASE ASSEMBLY(一)

序号 Pos.	图号 Teile. Number	组别 Sort	柴油机设计号 (件数) Engine SN Stk.				规格标准 DIN/Fremdfabr. Nr.	中文名称 Denomination	英文名称 Designation
			13020109	13020107	13020106	13020088			
25	01153805	01	12	8	6	6	116 * 4 - NBR - 1 - 60H2927	O 型密封圈	O - SEAL
26	01153804	01	12	8	6	6	114 * 1.6 H2927	O 型密封圈	O - SEAL
29	01113477	01	4	4	4	4	Q1201035	双头螺柱	STUD
30	13021999	01	4	4	4	4		六角螺母	HEXAGON BOLT
31	123166773	01	4	4	4	4	Q41210F9	平垫圈	PLAIN WASHER
32	01117867	01	4	4	4	4		齿形垫圈	TOOTH LOCK WASHER
33	12200620	01	16	10	10	10		气缸盖螺栓	CYLINDER HEAD BOLT
34	12200621	01	8	4				气缸盖螺栓	CYLINDER HEAD BOLT
34	13023589	01		2	2	2		气缸盖螺栓	CYLINDER HEAD BOLT
35	12165568	43	38	26	20	20		平垫圈	PLAIN WASHER
36	01115413	01	7	5	4	4	Q5280408	弹性圆柱销	STRAIGHT PIN
37	01105156	01	3	3	3	3	Q5210818	圆柱销	PARALLEL PIN
38	01105182	01	2	2	2	2	Q5211028	圆柱销	PARALLEL PIN
40	12164651	01	14	10	8	8		六角头螺栓	HEXAGON BOLT
44	12159445	01	1	1		1		套管	SLEEVE

机体总成二 CRANKCASE ASSEMBLY(二)

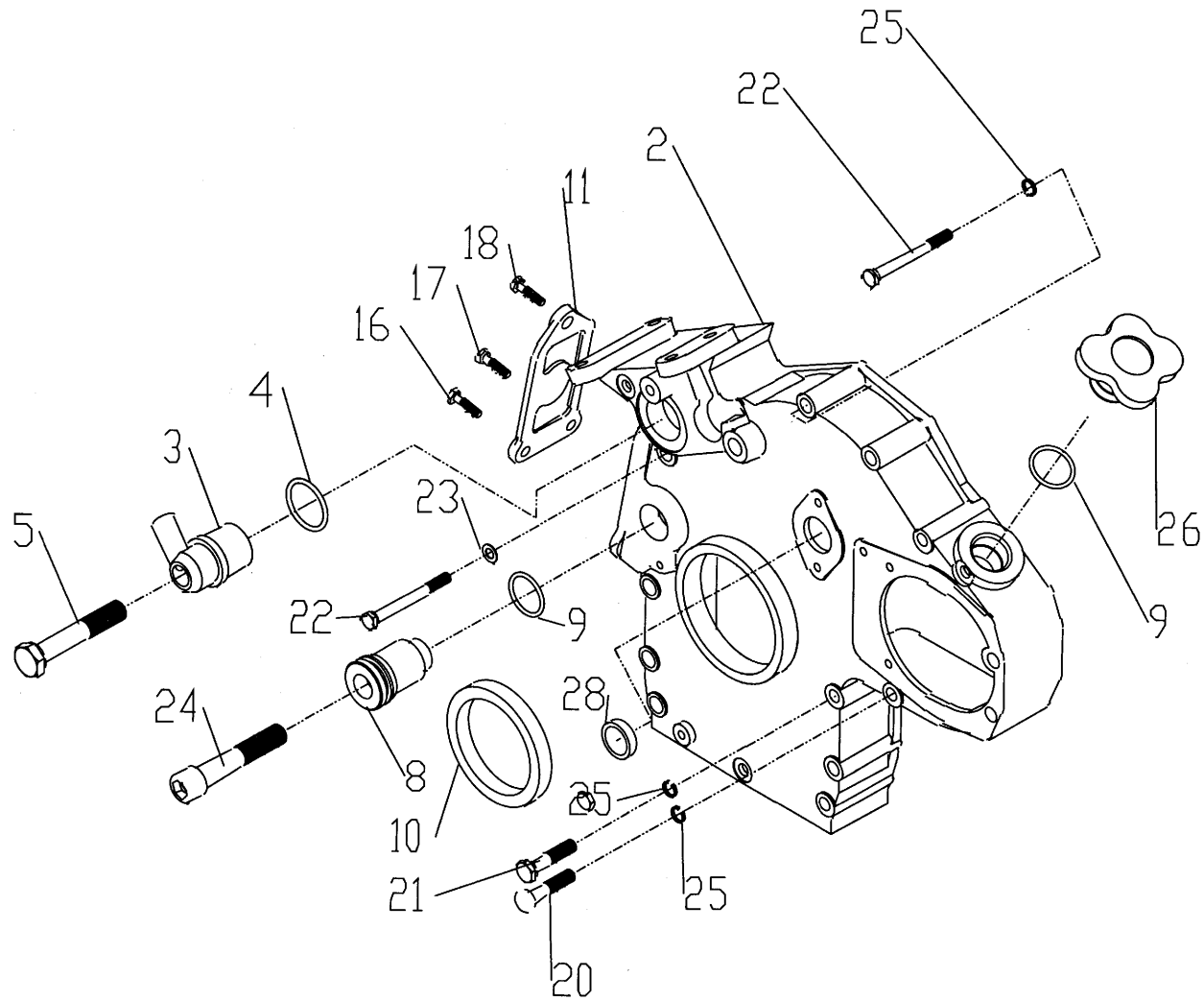

机体总成二 CRANKCASE ASSEMBLY(二)

序号 Pos.	图号 Teile. Number	组别 Sort	柴油机设计号 (件数) Engine SN Stk.				规格标准 DIN/Fremdfabr. Nr.	中文名称 Denomination	英文名称 Designation
			13020109	13020107	13020106	13020088			
2	13021714	01	1	1	1	1		前墙盖	CRANKC. END COVER
3	12158431	01	1	1	1	1		呼吸器体	HOUSING/CASE
4	01161340	01	1	1	1	1	40 * 4 - NBR - 1 - 60H2927	O 形密封圈	O - SEAL
5	01111096	01	1	1	1	1	Q150B0690	六角头螺栓	HEXAGON BOLT
8	12190581	01	1	1	1	1		轴	FLANGED BUSH
9	06214722	01	2	2	2	2	32 * 4 - NBR - 1 - 70H2927	O 形密封圈	O - SEAL
10	12188100	01	1	1	1	1		径向密封圈组件	ROTARY SHAFT SEAL
11	13020243	01	1	1	1	1		盖板	SHIELD
16	01112331	01	1	1	1	1	Q150B0825	六角头螺栓	HEXAGON BOLT
17	01137083	01	1	1	1	1	Q150B0820	六角头螺栓	HEXAGON BOLT
18	01112416	01	1	1	1	1	Q150B1025	六角头螺栓	HEXAGON BOLT
20	01139584	02	1	1	1	1	Q150B0835	六角头螺栓	HEXAGON BOLT
21	01111151	01	5	5	5	5	Q150B0845	六角头螺栓	HEXAGON BOLT
22	01111184	01	6	6	6	6	Q150B0875	六角头螺栓	HEXAGON BOLT
23	01118647	01	1	1	1	1	A8 * 11.5 - Cu DIN7603	密封垫圈	SEALING RING
24	01151462	01	1	1	1	1	M10 * 90 - 10.9 GB70	内六角圆柱头螺钉	CHEESE HEAD SCREW
25	01177981	01	11	11	11	11	Q40308	弹簧垫圈	SPRING LOCK WASHER
26	12165572	01	1	1	1	1		六角头螺塞	SCREW PLUG
28	01152711	01	1	1	1	1	30 DIN443	碗形塞	COVER

机体总成三 CRANKCASE ASSEMBLY(三)

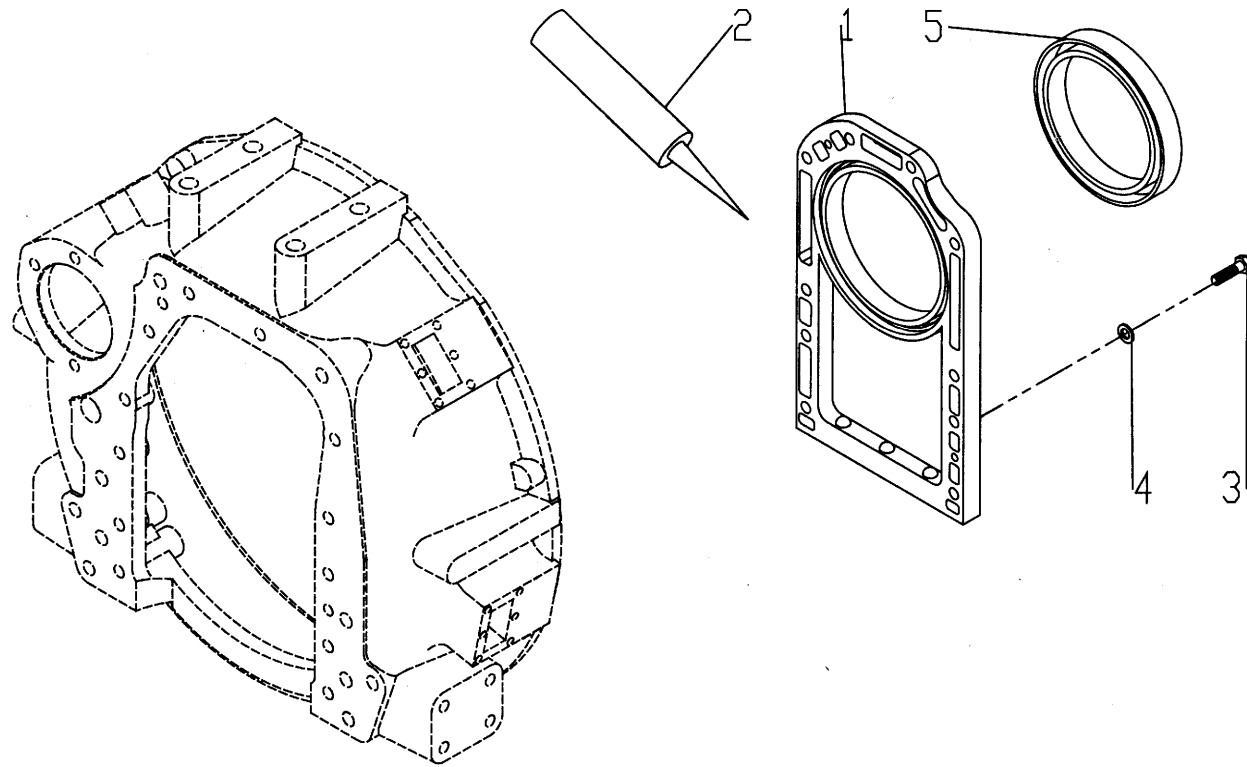

机体总成三 CRANKCASE ASSEMBLY(三)

序号 Pos.	图号 Teile. Number	组别 Sort	柴油机设计号 (件数) Engine SN Stk.				规格标准 DIN/Fremdfabr. Nr.	中文名称 Denomination	英文名称 Designation
			13020109	13020107	13020106	13020088			
1	12272177	09	1	1	1	1		后油封盖	REAR OIL SEAL COVER
2	01016240	01	*	*	*	*		密封剂	PACKING COMPOUND
3	01112331	01	10	10	10	10	Q150B0825	六角头螺栓	HEXAGON BOLT
4	01107281	01	10	10	10	10	Q41808	波形弹性垫圈	SPRING WASHER
5	12189888	05	1	1	1	1		径向密封圈	ROTARY SHAFT SEAL

机体总成四 CRANKCASE ASSEMBLY (四)

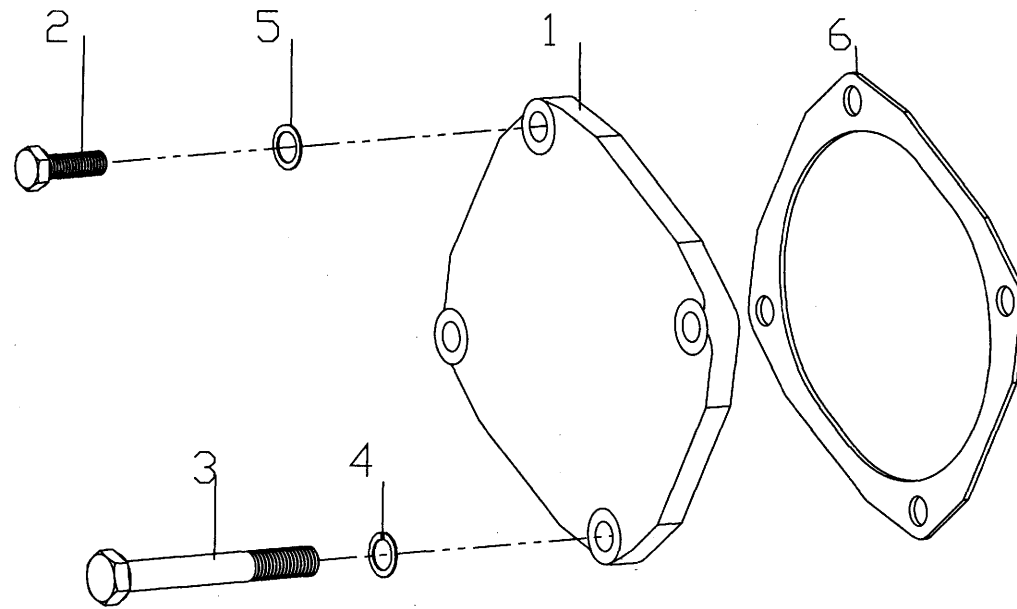

机体总成四 CRANKCASE ASSEMBLY(四)

序号 Pos.	图号 Teile. Number	组别 Sort	柴油机设计号 (件数) Engine SN Stk.				规格标准 DIN/Fremdfabr. Nr.	中文名称 Denomination	英文名称 Designation
			13020109	13020107	13020106	13020088			
1	12166808	01	1	1	1	1		堵盖 COVER	
2	01112331	16	1	2	2	2	Q150B0825	六角头螺栓 HEXAGON BOLT	
2	01112339	16	1				Q150B0830	六角头螺栓 HEXAGON BOLT	
3	01111198	01	2	2	2	2	Q150B0890	六角头螺栓 HEXAGON BOLT	
4	01177981	01	3	3	3	3	Q40308	弹簧垫圈 SPRING LOCK WASHER	
5	01118654	01	1	1	1	1	A8 * 14Cu DIN7603	密封垫圈 SEALING RING	
6	12189678	83	1	1	1	1		垫片 GASKET	

机体总成五

13020109

CRANKCASE ASSEMBLY (五)

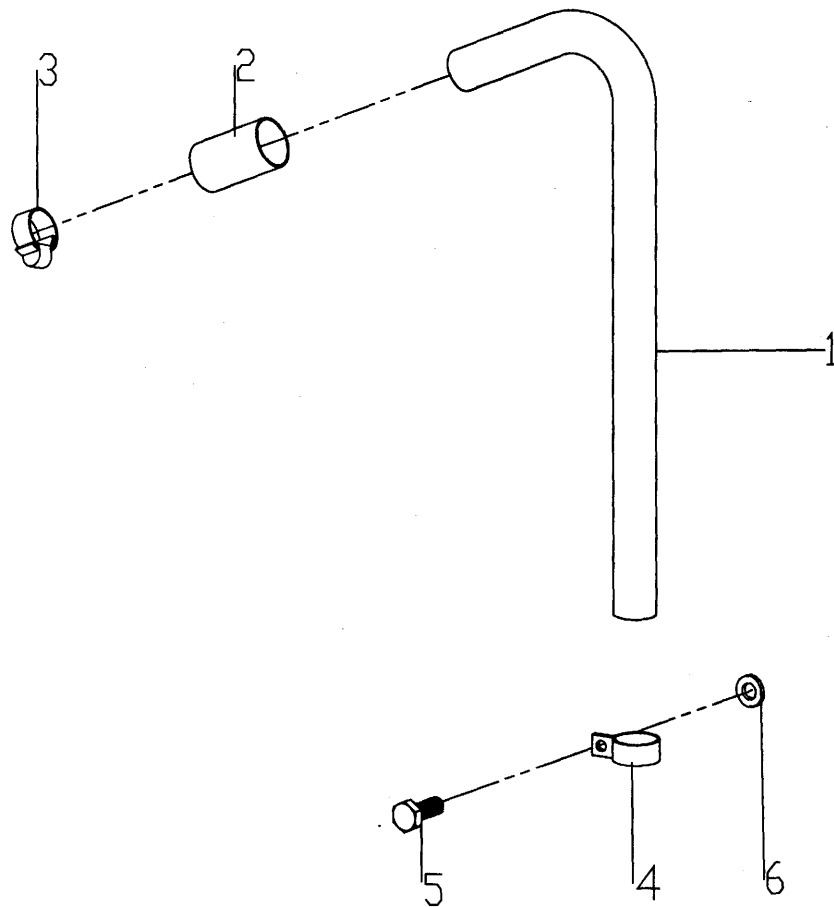

机体总成五 CRANKCASE ASSEMBLY(五)

序号 Pos.	图号 Teile. Number	组别 Sort	柴油机设计号 (件数) Engine SN Stk.				规格标准 DIN/Fremdfabr. Nr.	中文名称 Denomination	英文名称 Designation
			13020109	13020107	13020106	13020088			
1	12158667	01	1				弯管	PIPE CONNECTION	
2	01222738	01	1				软管	HOSE	
3	01137412	01	2			A116 - 25 - WIDIN3017	软管卡箍	HOST CLIP	
4	12151721	01	1			RS1100 20/20	软管卡箍	HOST CLIP	
5	00117083	01	1			Q150B0820	六角头螺栓	HEXAGON BOLT	
6	02404201	01	1				垫片	PLAIN WASHER	

13020107
13020106
13020088

机体总成五

CRANKCASE ASSEMBLY (五)

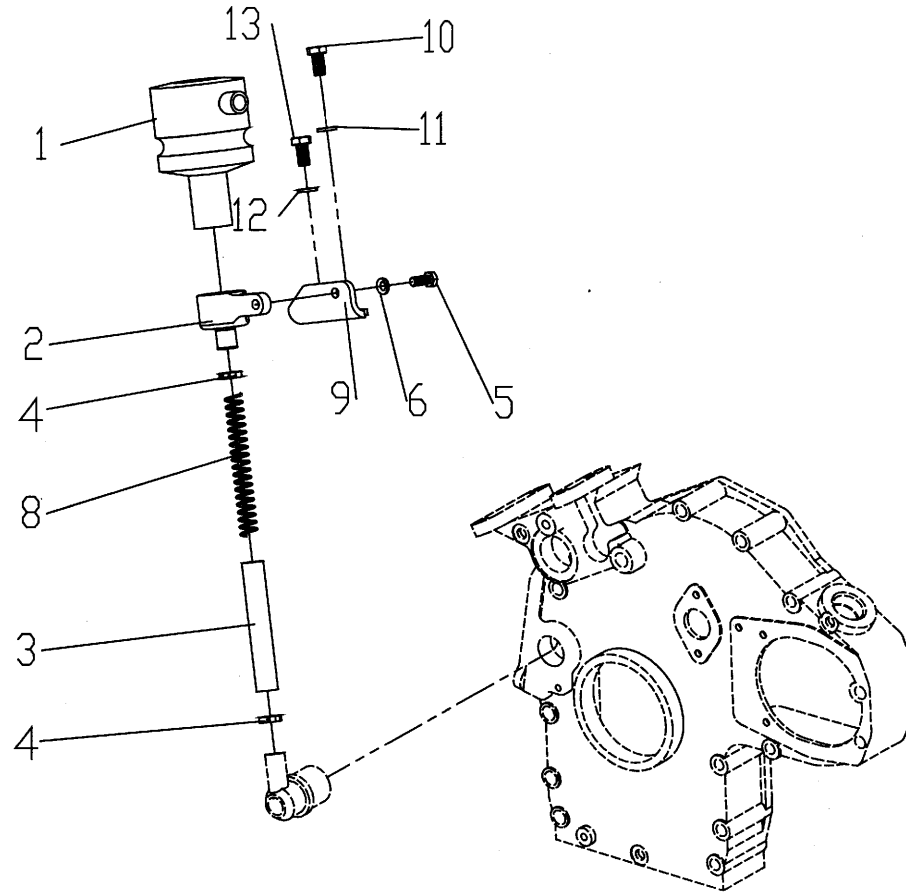

机体总成五 CRANKCASE ASSEMBLY(五)

序号 Pos.	图号 Teile. Number	组别 Sort	柴油机设计号 (件数) Engine SN Stk.				规格标准 DIN/Fremdfabr. Nr.	中文名称 Denomination	英文名称 Designation
			13020109	13020107	13020106	13020088			
1	12270387	01		1	1	1		油气分离器 OIL AND GAS SEPARATOR	
2	12270388	01		1	1	1		曲轴箱通风装置接头 AIRINESS TIE - IN	
3	01396634	01		1	1	1		软管 HOSE	
4	01137412	01		2	2	2		软管卡箍 HOST CLIP	
5	01112339	01		1	1	1	Q105B0830	六角头螺栓 HEXAGON BOLT	
6	01177981	01		1	1	1	Q40308	弹簧垫圈 SPRING LOCK WASHER	
8	12270389	01		1	1	1		弹簧 SPRING	
9	13024068	01		1	1	1		支架 BRACKET	
10	01112405	01		1	1	1	Q150B1020	六角头螺栓 HEXAGON BOLT	
11	01152752	01		1	1	1	Q40110	平垫圈 PLAIN WSHER	
12	01151002	01		1	1	1	Q40112	平垫圈 PLAIN WSHER	
13	13022007	01		1	1	1	Q150B1220	六角头螺栓 HEXAGON BOLT	

机体总成六 CRANKCASE ASSEMBLY(六)

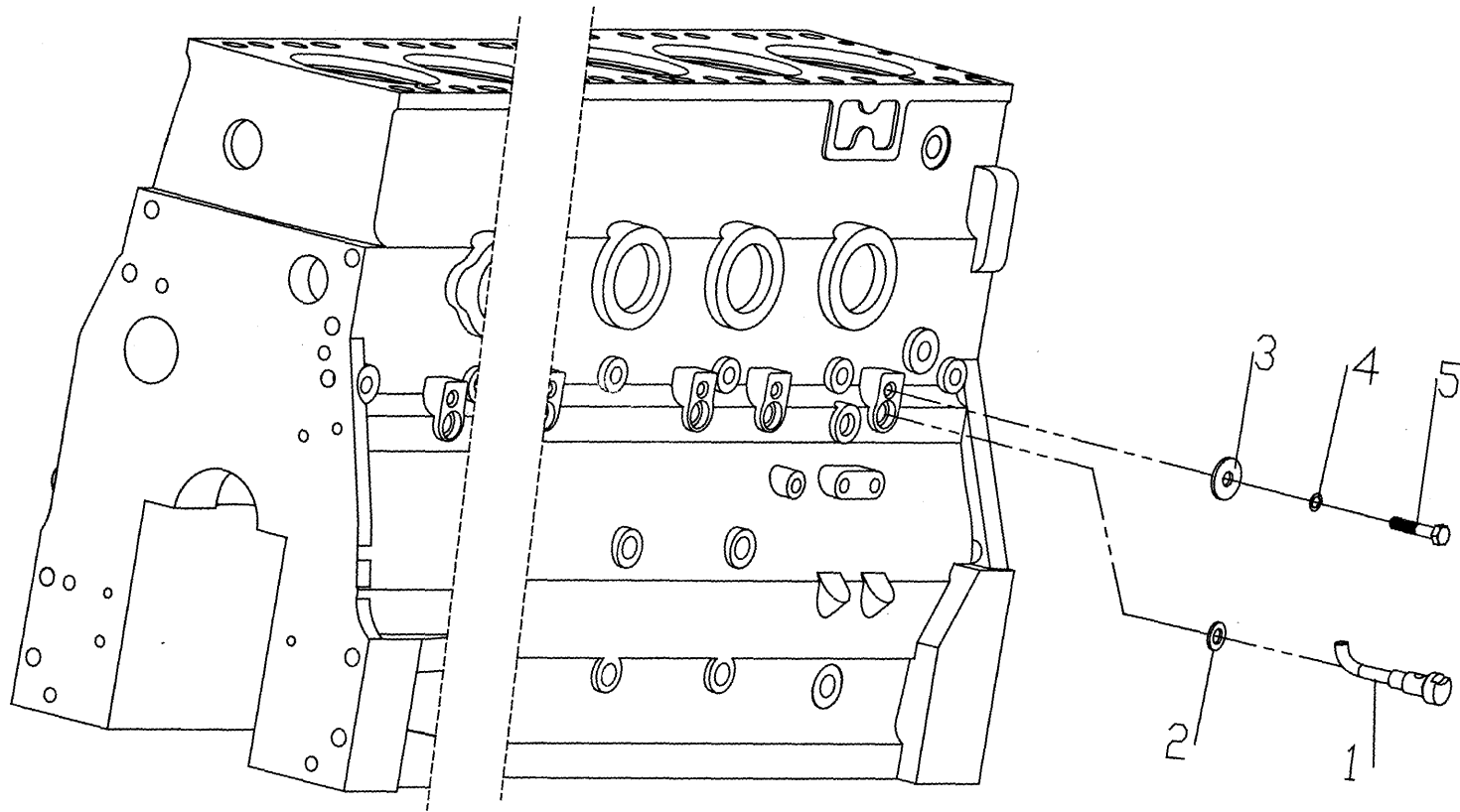

机体总成六 CRANKCASE ASSEMBLY(六)

序号 Pos.	图号 Teile. Number	组别 Sort	柴油机设计号 (件数) Engine SN Stk.				规格标准 DIN/Fremdfabr. Nr.	中文名称 Denomination	英文名称 Designation
			13020109	13020107	13020106	13020088			
1	12273763	01	6	4		3	冷却油喷嘴组件	NOZZLE	
2	01166001	01	6	4		3	O型密封圈	O - SEAL	
3	12164637	01	6	4		3	垫片	PLAIN WASHER	
4	01177981	01	6	4		3	弹簧垫圈	SPRING LOCK WASHER	
5	01151569	01	6	4		3	六角头螺栓	HEXAGON BOLT	

油底壳总成 OIL PAN ASSEMBLY

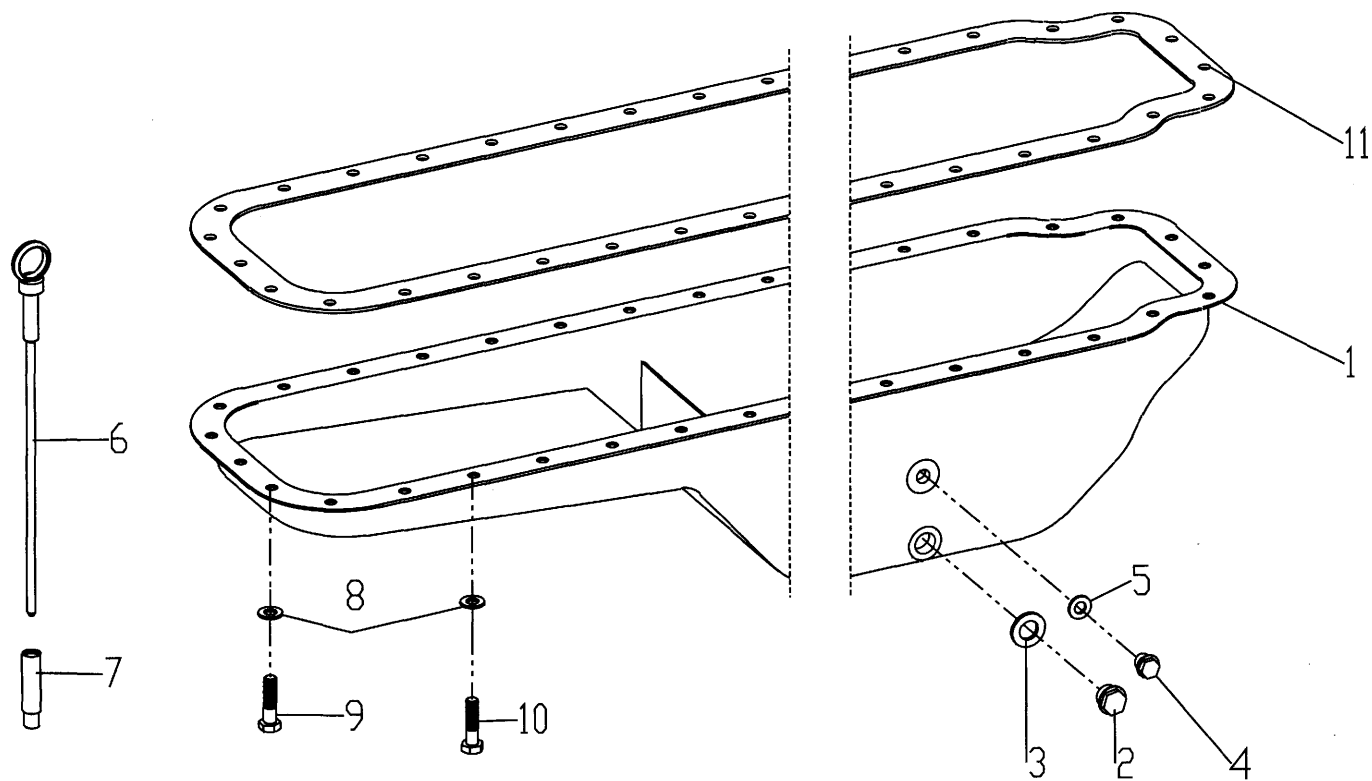

油底壳总成 OLL PAN ASSEMBLY

序号 Pos.	图号 Teile. Number	组别 Sort	柴油机设计号 (件数) Engine SN Stk.				规格标准 DIN/Fremdfabr. Nr.	中文名称 Denomination	英文名称 Designation
			13020109	13020107	13020106	13020088			
1	13022882	02	1					油底壳 OIL PAN	
1	12274896	02		1				油底壳 OIL PAN	
1	12273946	02			1	1		油底壳 OIL PAN	
2	01110445	02	1	1	1	1	G1/2A - ST DIN910	六角头螺塞 SCREW PLUG	
3	13023364	02	1	1	1	1	22JB982	组合密封垫圈 SEALING RING	
4	01133632	02	1	1	1	1	M14 * 1.5 - 5.8 DIN910	六角头螺塞 SCREW PLUG	
5	13023362	02	1	1	1	1	14 JB982	组合密封垫圈 SEALING RING	
6	12272672	02	1					油标尺 DIPSTICK	
6	12270444	02		1				油标尺 DIPSTICK	
6	12270442	02			1	1		油标尺 DIPSTICK	
7	12190556	02	1					油尺 TUBE	
7	13020273	02		1	1	1		油尺管管 TUBE	
8	01214459	08	33	25	21	21		平垫片 PLAIN WASHER	
9	01137083	02	7	7	7	7	Q150B0820	六角头螺栓 HEXAGON BOLT	
10	01112339	02	26	18	14	14	Q150B0830	六角头螺栓 HEXAGON BOLT	
11	13022863	02	1					密封垫片 SEALING WASHER	
11	12270876	02		1				密封垫片 SEALING WASHER	
11	12270875	02			1	1		密封垫片 SEALING WASHER	

曲轴总成 CRANKSHAFT ASSEMBLY

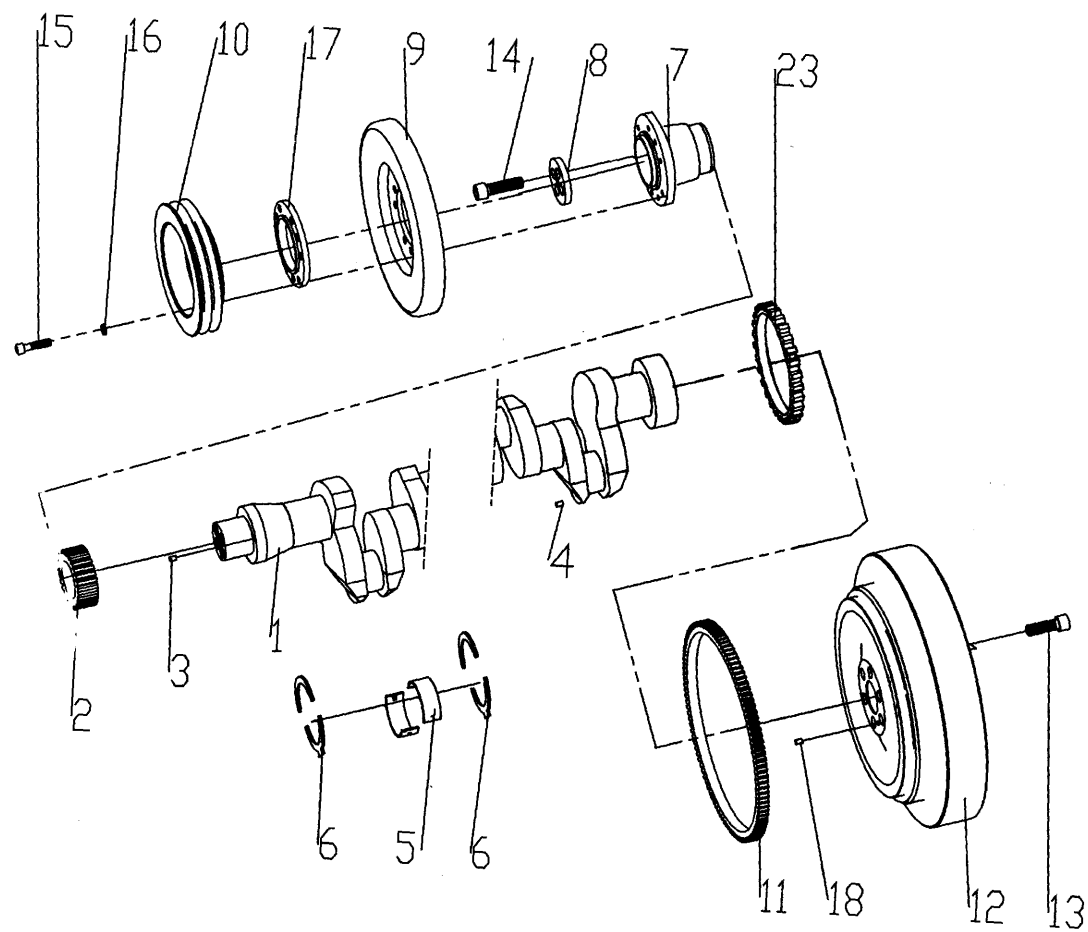

曲轴总成 CRANKSHAFT ASSEMBLY

序号 Pos.	图号 Teile. Number	组别 Sort	柴油机设计号 (件数) Engine SN Stk.				规格标准 DIN/Fremdfabr. Nr.	中文名称 Denomination	英文名称 Designation
			13020109	13020107	13020106	13020088			
1	12272497	05	1				Q5280414	曲轴	CRANKSHAFT
1	12272491	05		1				曲轴	CRANKSHAFT
1	12272487	05			1	1		曲轴	CRANKSHAFT
2	12273248	05	1	1	1	1		曲轴正时齿轮	TIMING GEAR
3	01115416	05	1	1	1	1		弹性圆柱销	DOWEL PIN
4	12151364	05	6	4	3	3		堵塞	PLUG
5	12189561	05	7					主轴瓦组件	MAIN BEARING
5	12160569	05		5	4	4		主轴瓦组件	MAIN BEARING
6	12160535	05	2	2	2	2		止推片组件	THRUST PIECES
7	12189567	05	1					轮毂	HUB
7	12160595	05		1				轮毂	HUB
7	12188194	05			1	1		轮毂	HUB
8	12160534	05	1	1	1	1		垫片	PLAIN WASHER
9	12272805	05	1					减震器	VIBRATION DAMPER
10	12272796	05	1					皮带轮	V - GROOVED PULLEY
10	13022503	05		1	1	1		皮带轮	V - GROOVED PULLEY
11	12166719	05	1	1	1	1		齿圈	GEAR RIM
12	13021863	05	1					飞轮	FLYWHEEL
12	13023261	05		1	1	1		飞轮	FLYWHEEL
13	01110847	05	6					M16 * 50 - 12.9GB70	内六角圆柱头螺钉
13	01112682	05		6	6	6	M16 * 40 - 12.9GB70	内六角圆柱头螺钉	HEXAGON BOLT

曲轴总成 CRANKSHAFT ASSEMBLY

序号 Pos.	图号 Teile. Number	组别 Sort	柴油机设计号 (件数) Engine SN Stk.				规格标准 DIN/Fremdfabr. Nr.	中文名称 Denomination	英文名称 Designation
			13020109	13020107	13020106	13020088			
14	01152870	05	4		4	4	N16 * 60 - 12.9GB70	内六角圆柱头螺钉	HEXAGON BOLT
14	01110847	05		4			M16 * 50 - 12.9GB70	内六角圆柱头螺钉	HEXAGON BOLT
15	01110678	05	9				M10 * 45 - 12.9GB70	内六角圆柱头螺钉	HEXAGON BOLT
15	01110659	05		6	6	6	M10 * 30 - 12.9GB70	内六角圆柱头螺钉	HEXAGON BOLT
16	01178365	05	9	6	6	6	Q40310	弹簧垫圈	SPRING LOCK WASHER
17	13022924	05	1					连接盘	ADAPTER
17	13020311	05			1	1			
18	01125638	05	1	1	1	1	Q5280610	弹性圆柱销	STRAIGHT PIN
23	12166718	05		1				二级平衡机构齿圈	MASS BLANCER GEAR RIM

二级平衡机构总成 MASS BLANCER ASSEMBLY

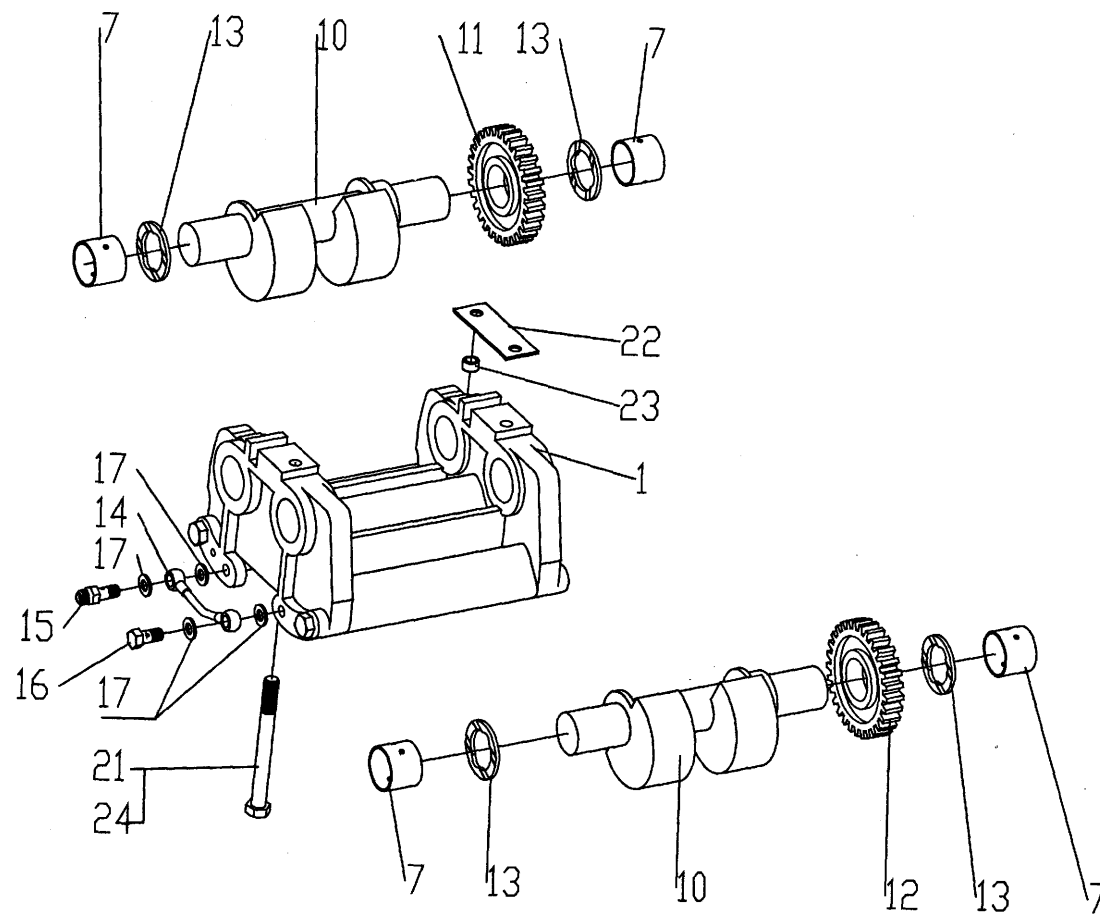

二级平衡机构总成 MASS BLANCER ASSEMBLY

序号 Pos.	图号 Teile. Number	组别 Sort	柴油机设计号 (件数) Engine SN Stk.				规格标准 DIN/Fremdfabr. Nr.	中文名称 Denomination	英文名称 Designation
			13020109	13020107	13020106	13020088			
1	12200346	05		1			二级平衡机构壳体组件	MASS BLANCER	
7	12200347	05		4			轴用衬套	LINING	
10	12200350	05		2			轴	SHAFT	
11	12200351	05		1			驱动齿轮	DRIVING GEAR	
12	12200352	05		1			从动齿轮	DRIVEN GEAR	
13	12200353	05		4			平衡止推片	THRUST PIECES	
14	12158826	16		1			润滑油管	LUBRICANT OIL PIPE	
15	12158759	05		1			接头	TIE - IN	
16	01153236	05		1		D6M - STH3102	空心螺栓	HOLLOW SCREW	
17	01118664	05		4		A10 * 14 - Cu DIN7603	密封垫圈	SEAL RING	
21	01151514	05		2		Q150B10105	六角头螺栓	HEXAGON BOLT	
22	12160137	05		6			调整垫片	SHIM	
23	12159449	05		2			定位套	LOCALIZER	
24	13021979	05		2		Q150B10110	六角头螺栓	HEXAGON BOLT	

连杆总成 CONNECTING ROD ASSEMBLY

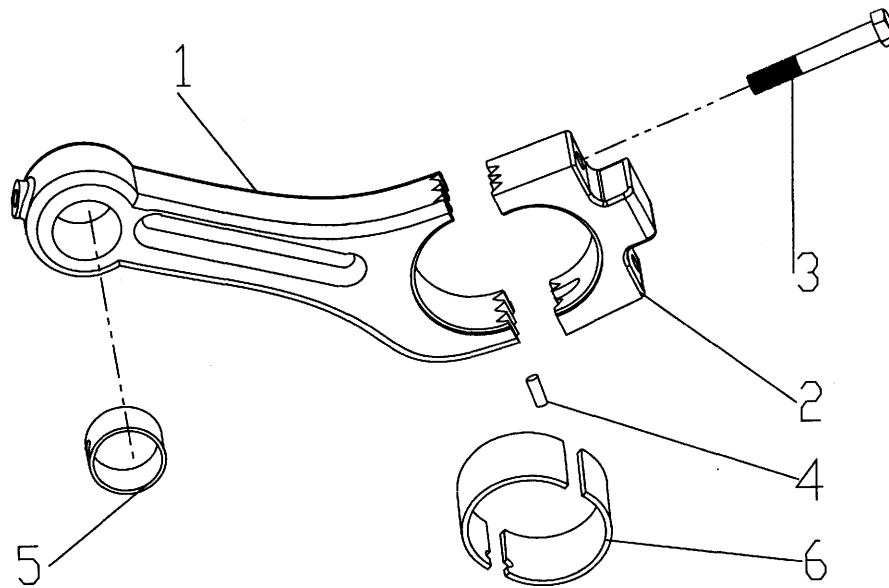

连杆总成 CONNECTING ROD ASSEMBLY

序号 Pos.	图号 Teile. Number	组别 Sort	柴油机设计号 (件数) Engine SN Stk.				规格标准 DIN/Fremdfabr. Nr.	中文名称 Denomination	英文名称 Designation
			13020109	13020107	13020106	13020088			
1	12273053	06	6	4	3	3	Q5280416	连杆体	CONNECTING ROD
2	12273054	06	6	4	3	3		连杆盖	CONNECTING COVER
3	12167047	06	12	8	6	6		连杆螺栓	BIG END BOLT
4	01154162	06	6	4	3	3		弹性圆柱销	STRAIGHT PIN
5	12159598	06	6	4	3	3		连杆衬套	BIG END BUSH
6	12200123	07	6					连杆瓦组件	BIG END BEARING
6	12160570	07		4	3	3	连杆瓦组件	BIG END BEARING	

活塞总成 PISTON ASSEMBLY

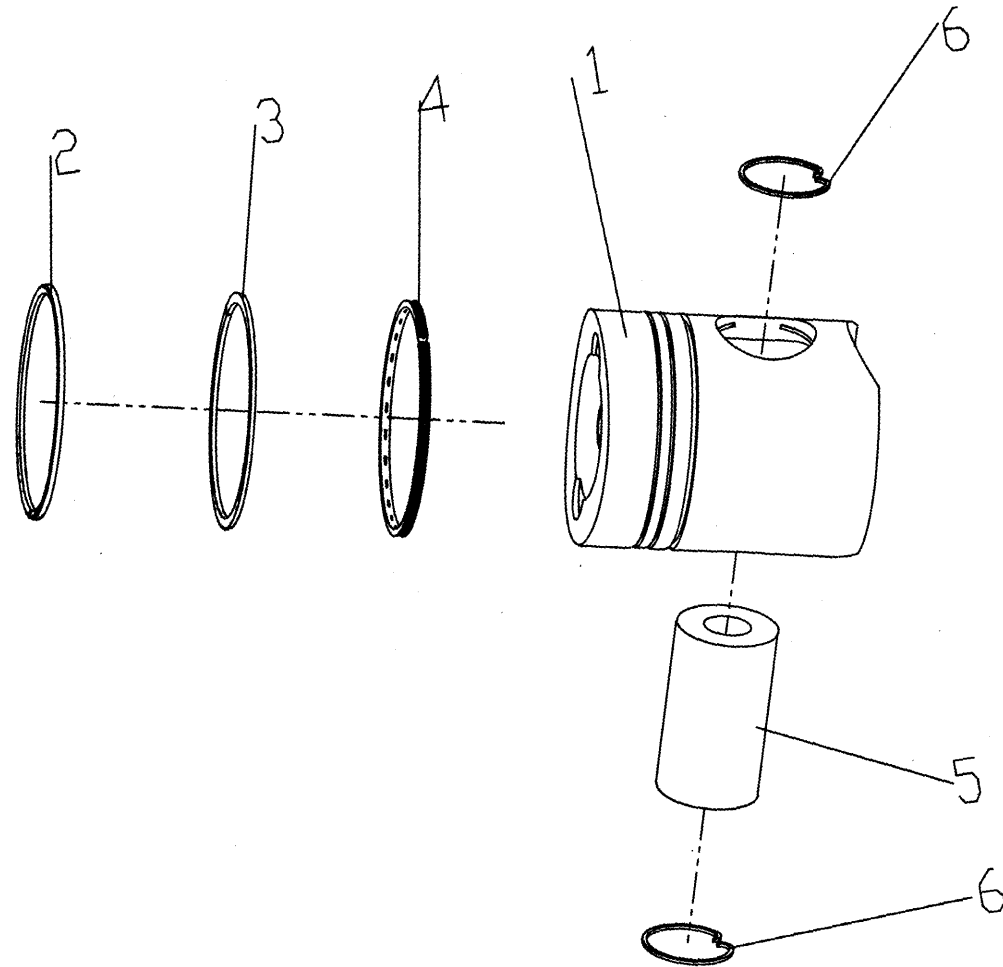

活塞总成 PISTON ASSEMBLY

序号 Pos.	图号 Teile. Number	组别 Sort	柴油机设计号 (件数) Engine SN Stk.				规格标准 DIN/Fremdfabr. Nr.	中文名称 Denomination	英文名称 Designation
			13020109	13020107	13020106	13020088			
1	12272090	07	6	4		3	活塞	PISTON	
1	12273861	07			3		活塞	PISTON	
2	12272097	07	6	4		3	梯形环	SET OF PIST. RINGS	
2	12152402	07			3		梯形环	SET OF PIST. RINGS	
3	12272098	07	6	4		3	锥面环	SET OF PIST. RINGS	
3	12270164				3		锥面环	SET OF PIST. RINGS	
4	12152429	07	6	4	3	3	螺旋撑簧油环	SET OF PIST. RINGS	
5	12152378	07	6	4		3	活塞销	PISTON PIN	
5	01154078	07			3		活塞销	PISTON PIN	
6	12151395	07	12	8	6	6	弹性挡圈	SPRING CLIP	

气缸盖罩总成 CYLINDER HEAD COVER ASSEMBLY

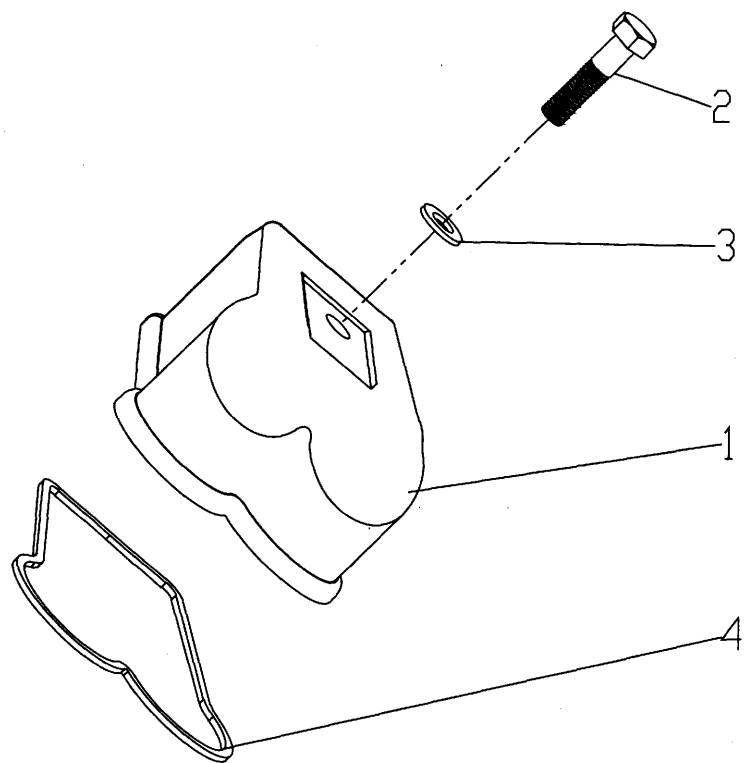

气缸盖罩总成 CYLINDER HEAD COVER ASSEMBLY

序号 Pos.	图号 Teile. Number	组别 Sort	柴油机设计号 (件数) Engine SN Stk.				规格标准 DIN/Fremdfabr. Nr.	中文名称 Denomination	英文名称 Designation
			13020109	13020107	13020106	13020088			
1	12159819	08	6	4	3	3		气缸盖罩 CYLINDER HEAD COVER	
2	01139584	08	6	4	3	3	Q150B0835	六角头螺栓 HEXAGON BOLT	
3	01118654	08	6	4	3	3	A8 * 14 - Cu DIN7603	密封垫圈 SEALING RING	
4	12270879	08	6	4	3	3		气缸盖罩密封垫 GASKET, CYLINDER HEAD COVER	

气缸盖总成 CYLINDER HEAD ASSEMBLY

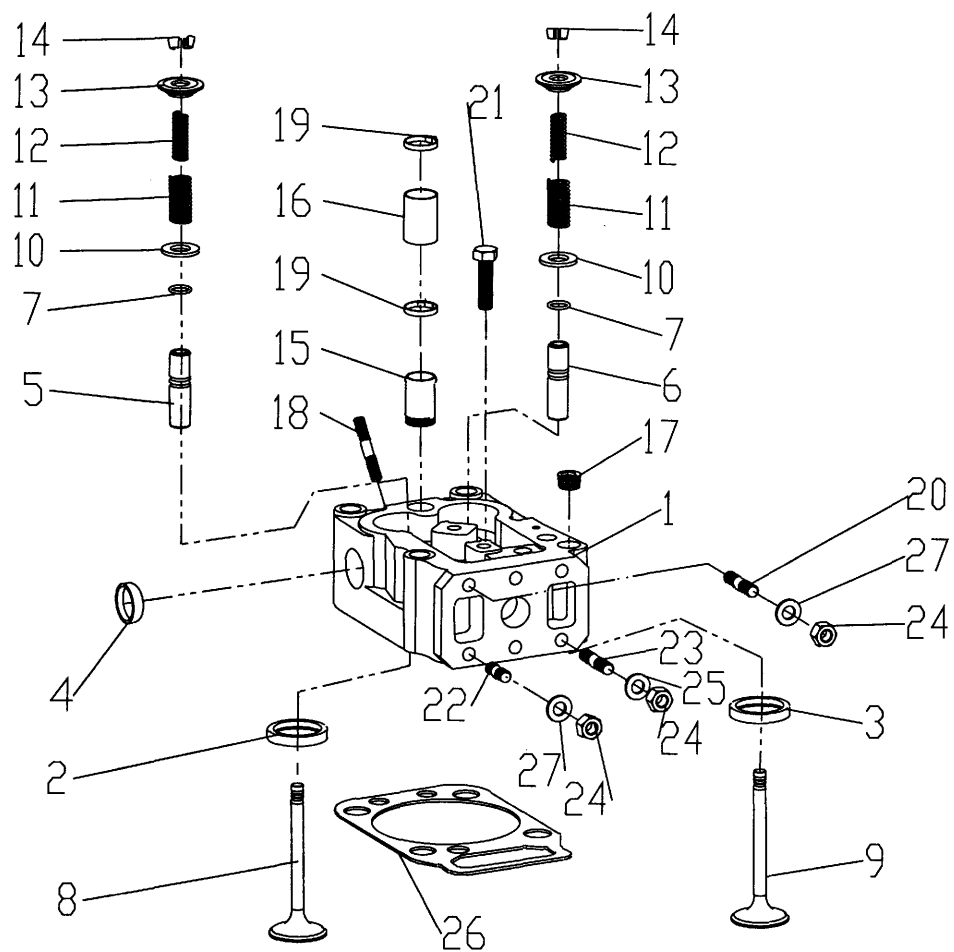

气缸盖总成 CYLINDER HEAD ASSEMBLY

序号 Pos.	图号 Teile. Number	组别 Sort	柴油机设计号 (件数) Engine SN Stk.				规格标准 DIN/Fremdfabr. Nr.	中文名称 Denomination	英文名称 Designation
			13020109	13020107	13020106	13020088			
1	15040081	08	6					气缸盖	CYLINDER HEAD
1	12273865	08		4	3	3		气缸盖	CYLINDER HEAD
2	12188202	08	6	4	3	3		进气门座	INLET VALVE SEAT
3	12188201	08	6	4	3	3		排气门座	EXHAUST VALVE SEAT
4	01152710	08	24	12	9	9		碗形塞	COVER
5	12189512	08	6	4	3	3		气门导管(进)	VALVE GUIDE
6	12159459	08	6	4	3	3		气门导管(排)	VALVE GUIDE
7	01153875	08	12	8	6	6	9*1.5-FRM-1-82-H2927	O型密封圈	O-SEAL
8	12159606	08	6	4	3	3		进气门	INLET VALVE
9	12159608	08	6	4	3	3		排气门	EXHAUST VALVE
10	12167040	08	12	8	6	6		垫片	PLAIN WASHER
11	01222051	08	12	8	6	6		气门弹簧(外)	COMPRESSION SPRING
12	01222009	08	12	8	6	6		气门弹簧(内)	COMPRESSION SPRING
13	12164645	08	12	8	6	6		气门弹簧座	SPRING CAP
14	12164698	08	24	16	12	12		气门锁夹	VALVE COLLET
15	12188750	08	6					管接头	PIPE CONNECTION
16	12200327	08	6					软管	TUBING CONNECTION
17	01104736	08	6	8	6	6	M22*1.5-5.8-DIN906	内六角锥形螺塞	SCREW PLUG
18	01152538	08	12	8	6	6	Q1200840	双头螺柱	HOSE CLIP
19	12151665	08	12					软管卡箍	HOST CLIP
20	01152500	08	12	4	3	3	12010100	双头螺柱	STUD

气缸盖总成 CYLINDER HEAD ASSEMBLY

序号 Pos.	图号 Teile. Number	组别 Sort	柴油机设计号 (件数) Engine SN Stk.				规格标准 DIN/Fremdfabr. Nr.	中文名称 Denomination	英文名称 Designation
			13020109	13020107	13020106	13020088			
21	01112445	08	12	8	6	6	Q150B1040	六角头螺栓	HEXAGON BOLT
22	01113465	08	12				Q1201025	双头螺柱	STUD
22	01113472				8	6	6	Q1201030	双头螺柱
23	01152504	08	12	8	6	6	Q1201040	双头螺柱	STUD
24	13020378	08	24	20	15	15	M10 - 10(对边 15)	六角螺母	NUT
25	12163182	08	12	8	6	6		垫片	PLAIN WASHER
26	12272058	08	6	4	3	3		气缸盖密封垫	CYLINDER HEAD GASKET
27	12167216	08		12	9	9		垫片	PLAIN WASHER

凸轮轴总成 CAMSHAFT ASSEMBLY

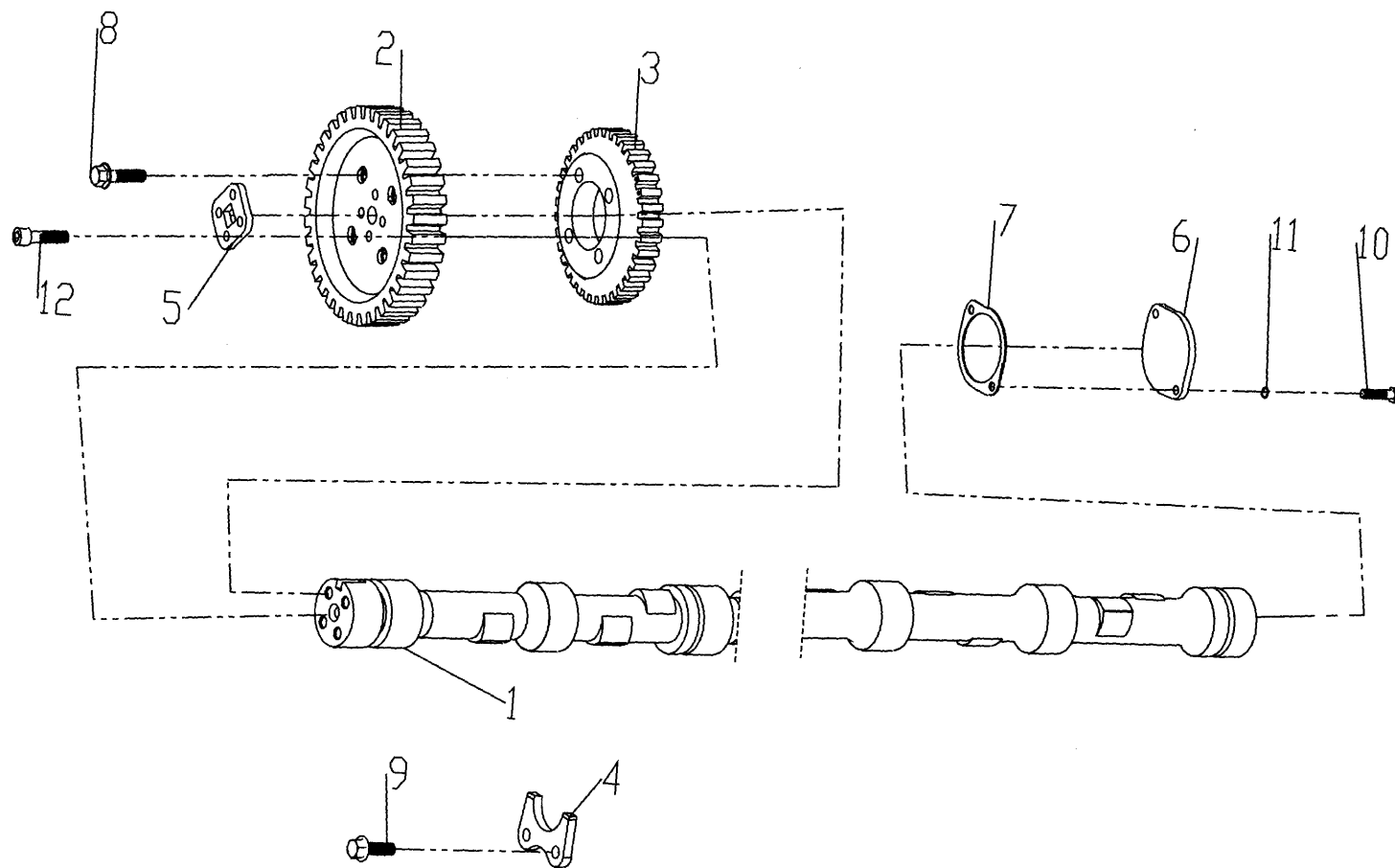

凸轮轴总成 CAMSHAFT ASSEMBLY

序号 Pos.	图号 Teile. Number	组别 Sort	柴油机设计号 (件数) Engine SN Stk.				规格标准 DIN/Fremdfabr. Nr.	中文名称 Denomination	英文名称 Designation
			13020109	13020107	13020106	13020088			
1	12200610	10	1				凸轮轴	CAMSHAFT	
1	13024219	10		1			凸轮轴	CAMSHAFT	
1	13024220	10			1	1	凸轮轴	CAMSHAFT	
2	12189556	10	1	1	1	1	凸轮轴齿轮	CAMSHAFT	
3	12189557	17	1				驱动喷油泵齿轮	OIL PUMP	
3	12189537	17		1	1	1	驱动喷油泵齿轮	OIL PUMP	
4	12159721	10	1	1	1	1	扇形板	QUADRANT/PLATE	
5	12189558	10	1	1	1	1	法兰	SHAPED FLANGE	
6	12160109	10	1	1	1	1	法兰	SHAPED FLANGE	
7	12190248	10	1	1	1	1	耐油石棉橡胶板 NY300 - § 10TB539	垫片	GASKET
8	01157293	09	4	4	4	4	AM8 * 22 - 12.9H2009	六角法兰承面带齿螺栓	LOCKING SCREW
9	01157294	09	2	2	2	2	Q1800816	六角法兰承面带齿螺栓	LOCKING SCREW
10	01137083	07	2	2	2	2	Q150B0820	六角头螺栓	HEXAGON BOLT
11	01177981	10	2	2	2	2	Q40308	弹簧垫圈	SPRING LOCK WASHER
12	01139989	10	4	4	4	4	M10 * 1.5 * 25 - 12.9 DIN912	内六角圆柱头螺钉	HEXAGON BOLT

摇臂座总成 ROCKER ARM BRACKET ASSEMBLY

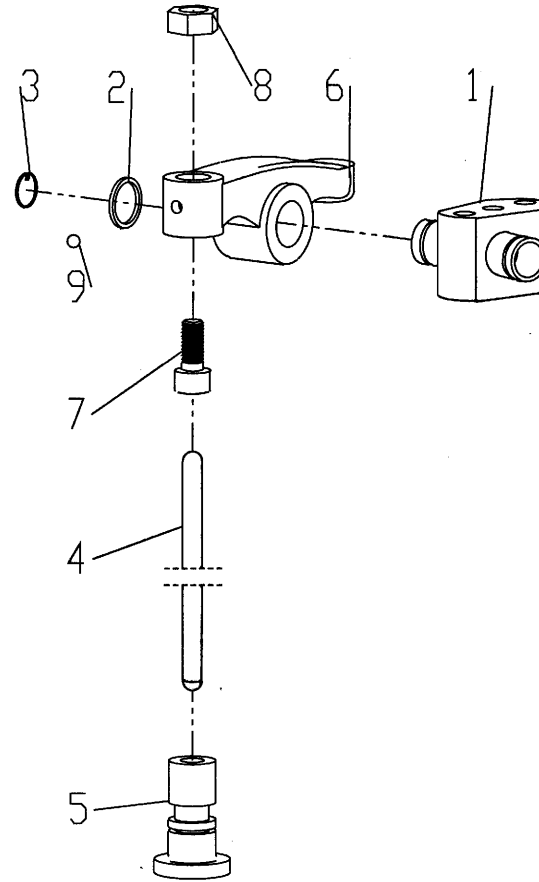

摇臂座总成 ROCKER ARM BRACKET ASSEMBLY

序号 Pos.	图号 Teile. Number	组别 Sort	柴油机设计号 (件数) Engine SN Stk.				规格标准 DIN/Fremdfabr. Nr.	中文名称 Denomination	英文名称 Designation
			13020109	13020107	13020106	13020088			
1	12159630	11	6	4	3	3	Q43116	摇臂座	ROCKER ARM BRACKET
2	12165314	11	24	16	12	12		碟型弹簧垫圈	SPRING LOCK WASHER
3	01107724	08	12	8	6	6		轴用弹性挡圈	CIRCLIPS
4	12159194	11	12	8	6	6		推杆	PUSHROD
5	12273399	11	12	8	6	6		挺柱	TAPPET
6	12214103	11	12	8	6	6		摇臂	ROCKER ARM
7	12159522	11	12	8	6	6		调节螺钉	ADJUSTING SCREW
8	12159526	11	12	8	6	6		六角螺母	HEXAGON NUT
9	01116947	08	12	8	6	6	3 GB308 球	BALL	

机油泵总成 OIL PUMP ASSEMBLY

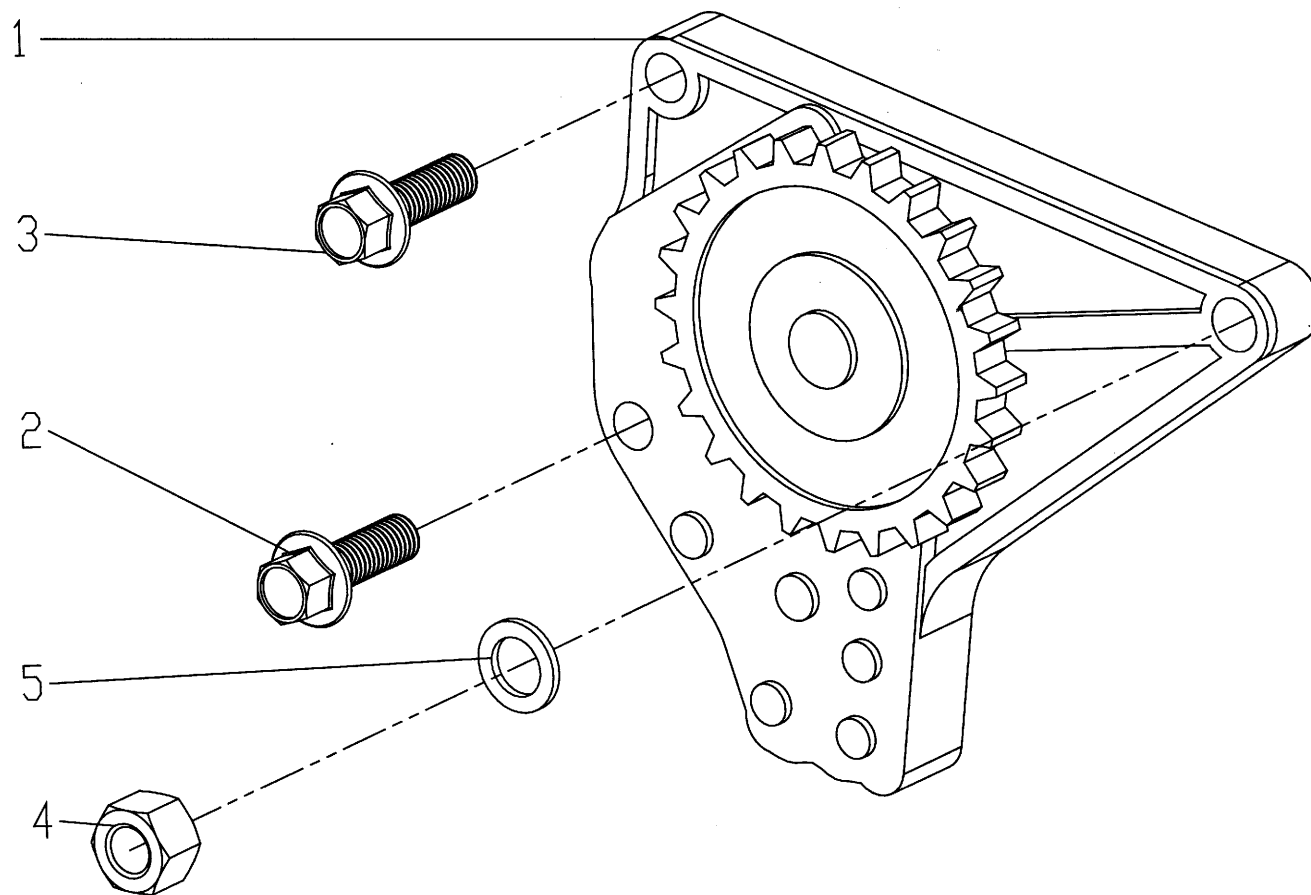

机油泵总成 OIL PUMP ASSEMBLY

序号 Pos.	图号 Teile. Number	组别 Sort	柴油机设计号 (件数) Engine SN Stk.				规格标准 DIN/Fremdfabr. Nr.	中文名称 Denomination	英文名称 Designation
			13020109	13020107	13020106	13020088			
1	12159765	14	1					机油泵分总成	GEAR. OIL PUMP
1	12166779	14		1				机油泵分总成	GEAR. OIL PUMP
1	12166769	14			1	1		机油泵分总成	GEAR. OIL PUMP
2	01156339	14	1	1	1	1	AM8 * 35 - 12.9 H2009	六角法兰承面带齿螺栓	LOCKING SCREW
3	01157293	14	1	1	1	1	AM8 * 22 - 12.9 H209	六角法兰承面带齿螺栓	LOCKING SCREW
4	12151228	14	1	1	1	1	HC - M8	螺母	NUT
5	12159468	14	1	1	1	1		垫片	PLAIN WASHER

13020109

润滑油进油管总成

13020107

LUBRICATING OIL LINE ASSEMBLY

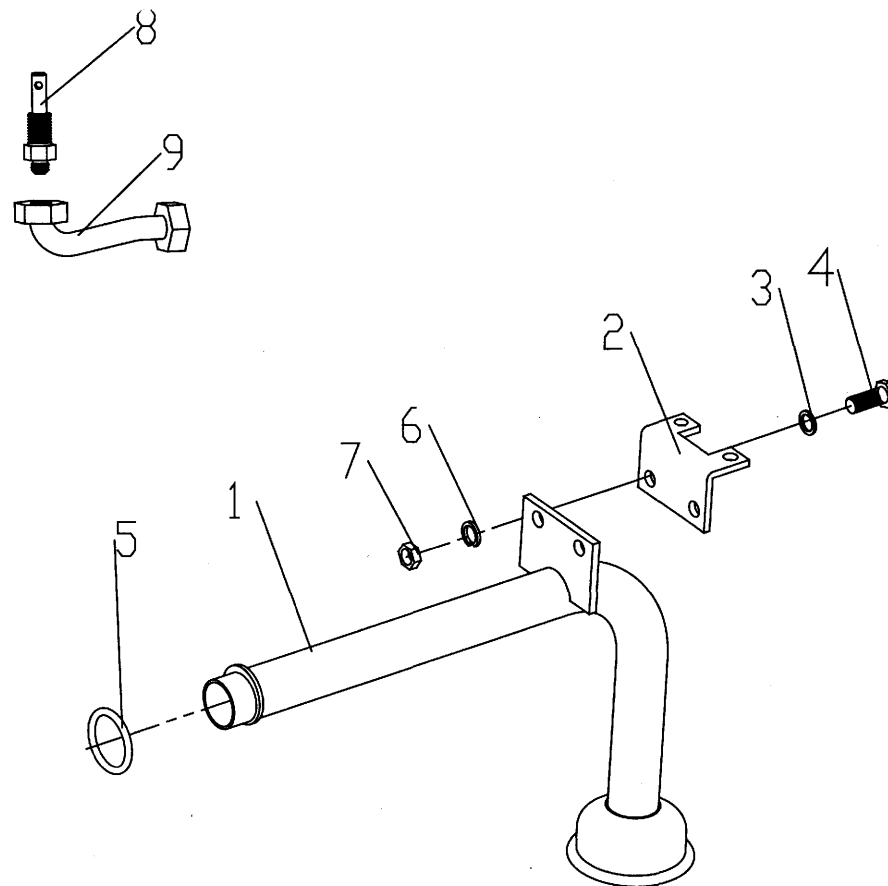

13020106
13020088

润滑油进油管总成 LUBRICATING OIL LINE ASSEMBLY

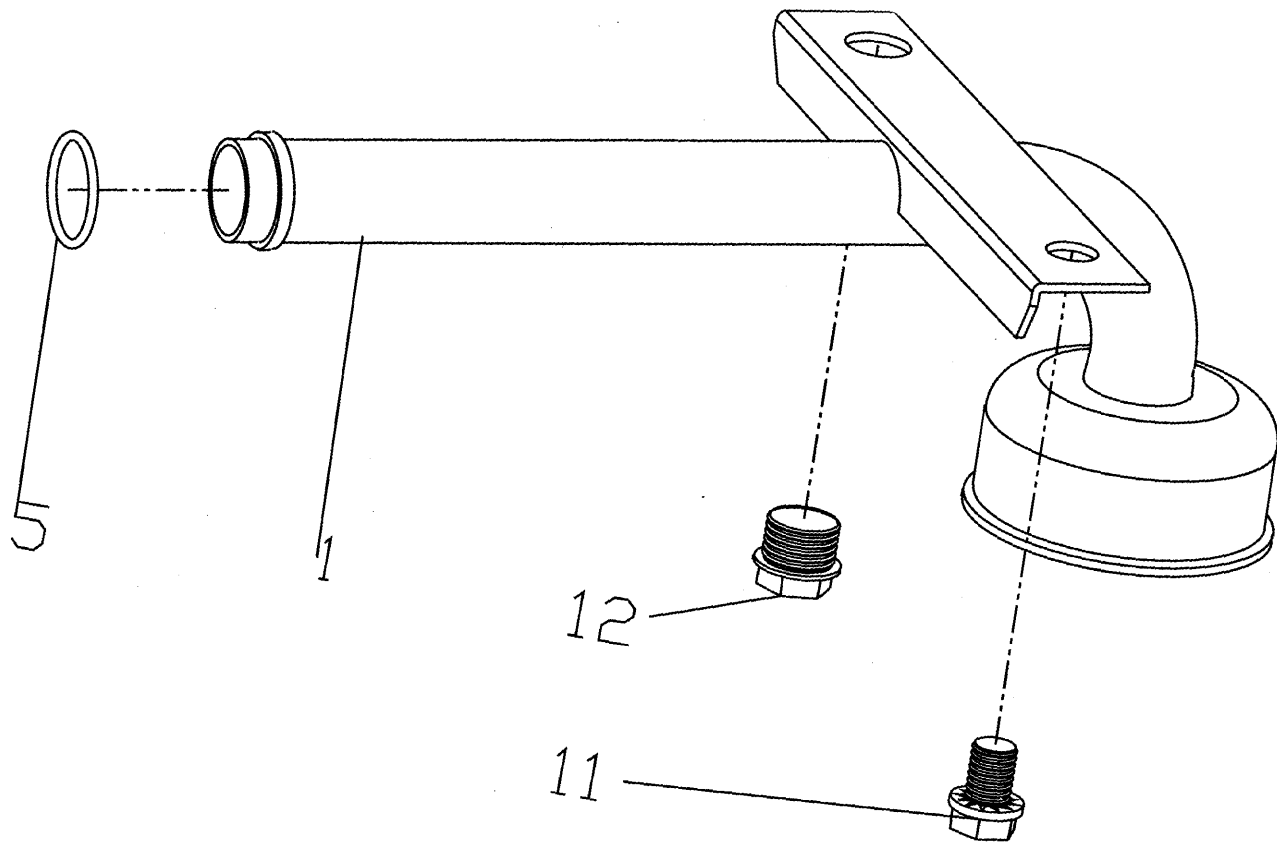

润滑油进油管总成 LUBRICATING OIL LINE ASSEMBLY

序号 Pos.	图号 Teile. Number	组别 Sort	柴油机设计号 (件数) Engine SN Stk.				规格标准 DIN/Fremdfabr. Nr.	中文名称 Denomination	英文名称 Designation
			13020109	13020107	13020106	13020088			
1	12159895	16	1				润滑油进油管组件	LUBRICATING OIL LINE ASSEMBLY	
1	12189078	16		1			润滑油进油管组件	LUBRICATING OIL LINE ASSEMBLY	
1	12166829	16			1	1	润滑油进油管组件	LUBRICATING OIL LINE ASSEMBLY	
2	12160163	16	1	1			角板	ANGLE PLATE	
3	01214459	08	2	2			垫片	PLAIN WASHER	
4	01112331	16	2	2		Q150B0825	六角头螺栓	HEXAGON BOLT	
5	01153874	16	1			25 * 4FPM - 1 - 60H2927	O 型密封圈	O - SEAL	
5	01153868	16		1	1	20 * 4FPM - 1 - 60H2927	O 型密封圈	O - SEAL	
6	01177981	16	2	2		Q40308	弹簧垫圈	SPRING LOCK WASHER	
7	01112829	16	2	2		Q360B08	六角螺母	II - HEXAGON NUT	
8	12166701	16		1			螺纹接头	THREADED JOINT	
9	12166832	16		1			润滑油压力管组件	LUBR. OIL SUC. PIPE	
11	01157294	16			1	1	六角法兰承面带齿螺栓	LOCKING SCREW	
12	01151453	16			1	1	M16 * 1.5 - STDIN910 六角头螺塞	SCREW PLUG	

13020109

润滑油管总成一 OIL SUCTION LINE ASSEMBLY (一)

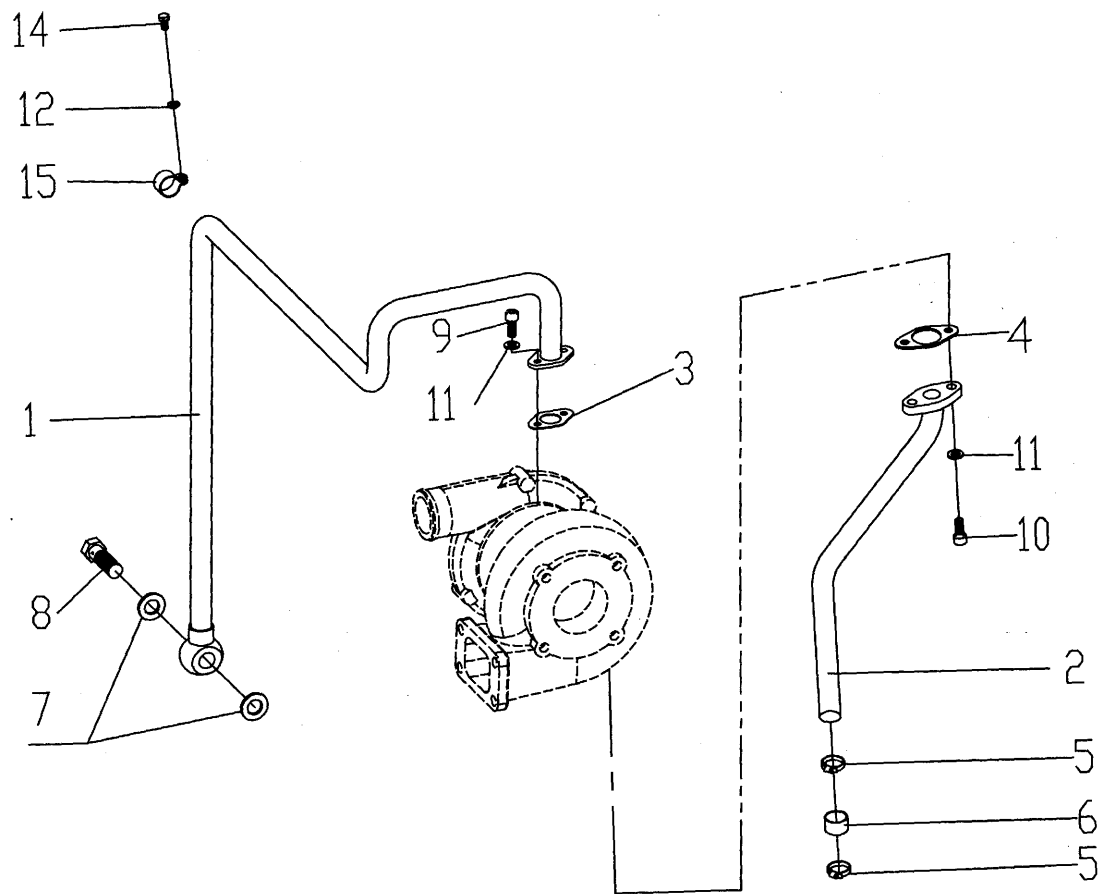

13020107

润滑油管总成一 OIL SUCTION LINE ASSEMBLY(一)

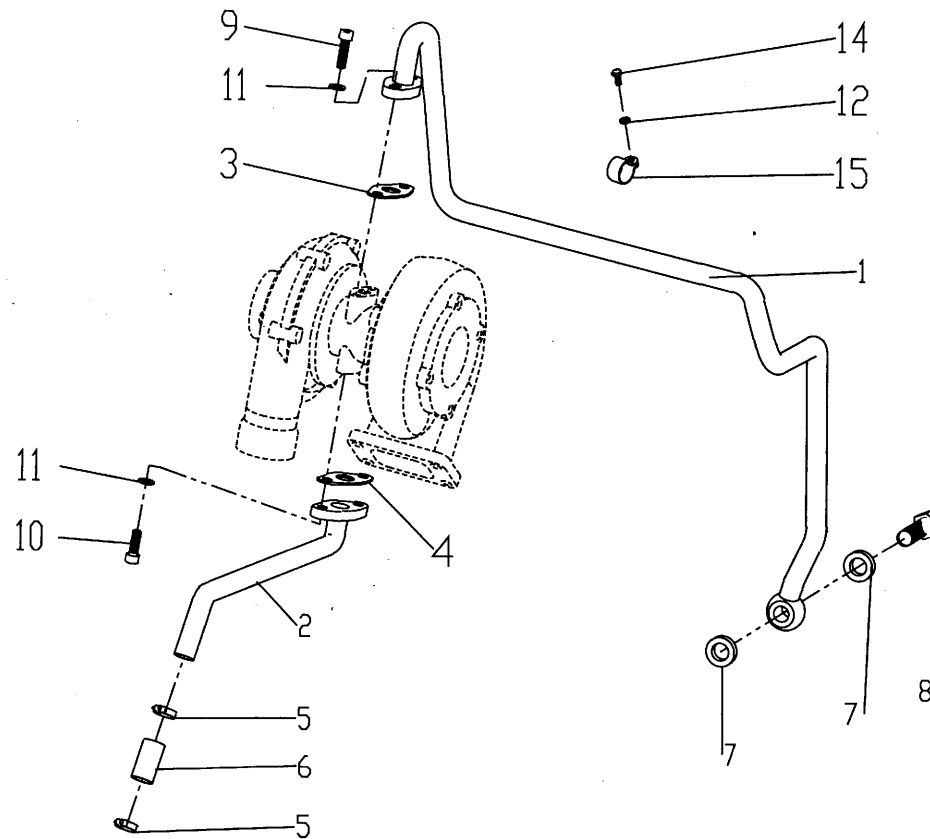

13020088

润滑油管总成一 OIL SUCTION LINE ASSEMBLY(一)

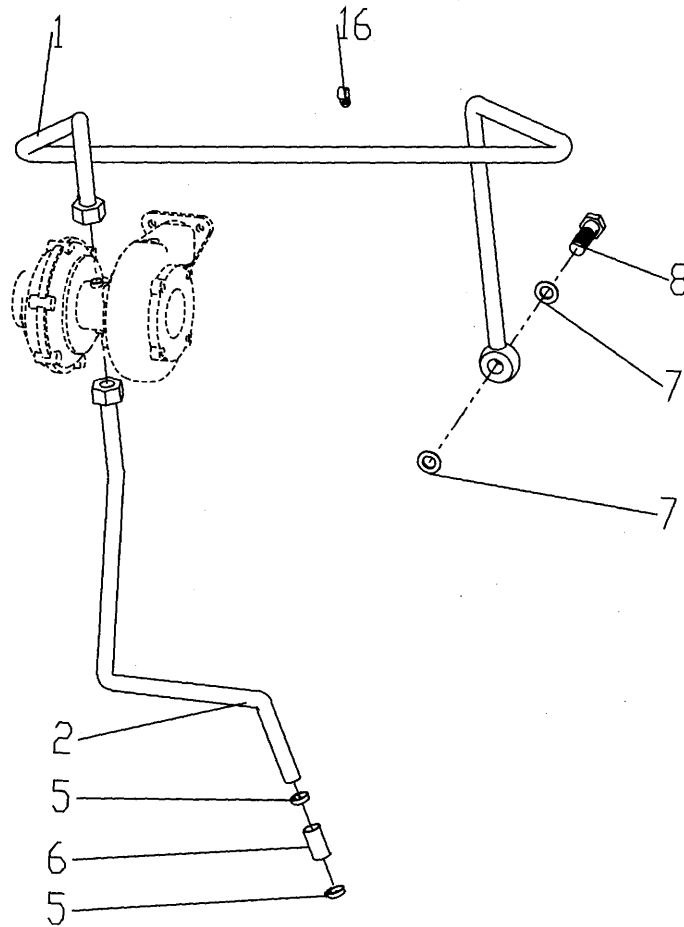

润滑油管总成一 OIL SUCTION LINE ASSEMBLY(一)

序号 Pos.	图号 Teile. Number	组别 Sort	柴油机设计号 (件数) Engine SN Stk.				规格标准 DIN/Fremdfabr. Nr.	中文名称 Denomination	英文名称 Designation
			13020109	13020107	13020106	13020088			
1	13020408		1				增压器进油管组件	LUBRICATING OIL LINE	
1	12273045	43		1			增压器进油管组件	LUBRICATING OIL LINE	
1	12270432					1	增压器进油管组件	LUBRICATING OIL LINE	
2	13021548	43	1				增压器回油管组件	LUBRICATING OIL LINE	
2	12191070	43		1			增压器回油管组件	LUBRICATING OIL LINE	
2	13022855	43				1	增压器回油管组件	LUBRICATING OIL LINE	
3	12161797	16	1	1			垫片	PLAIN WASHER	
4	12161798	43	1	1			垫片	PLAIN WASHER	
5	12151665	16	2	2		2	Q67535 软管卡箍	PIPE CLAMP	
6	12159875	43	1	1		1	软管	TUBE	
7	13023361	16	2	2		2	16JB982 组合密封垫圈	SEALING RING	
8	01119248	16	1	1		1	D12M - STH3102 空心螺栓	HOLLOW SCREW	
9	01110560	16	2	2			M8 * 20 - 12.9GB70 内六角圆柱头螺钉	CHESSE HEAD SCREW	
10	01110571	16	2	2			M8 * 25 - 12.9GB70 内六角圆柱头螺钉	CHESSE HEAD SCREW	
11	01177981	16	4	4			Q40308 弹簧垫圈	SPRING LOCK WASHER	
12	01107279	16	1	1			Q41806 波形弹性垫圈	SPRING WASHER	
14	01112238	16	1	1			Q150B0612 六角头螺栓	HEXAGON BOLT	
15	12210090	16	1	1			RS110 12/15 管夹	HOSE CLIP	
16	12163951	16				1	软管卡箍	PIPE CLAMP	

润滑油管总成二 OIL SUCTION LINE ASSEMBLY(二)

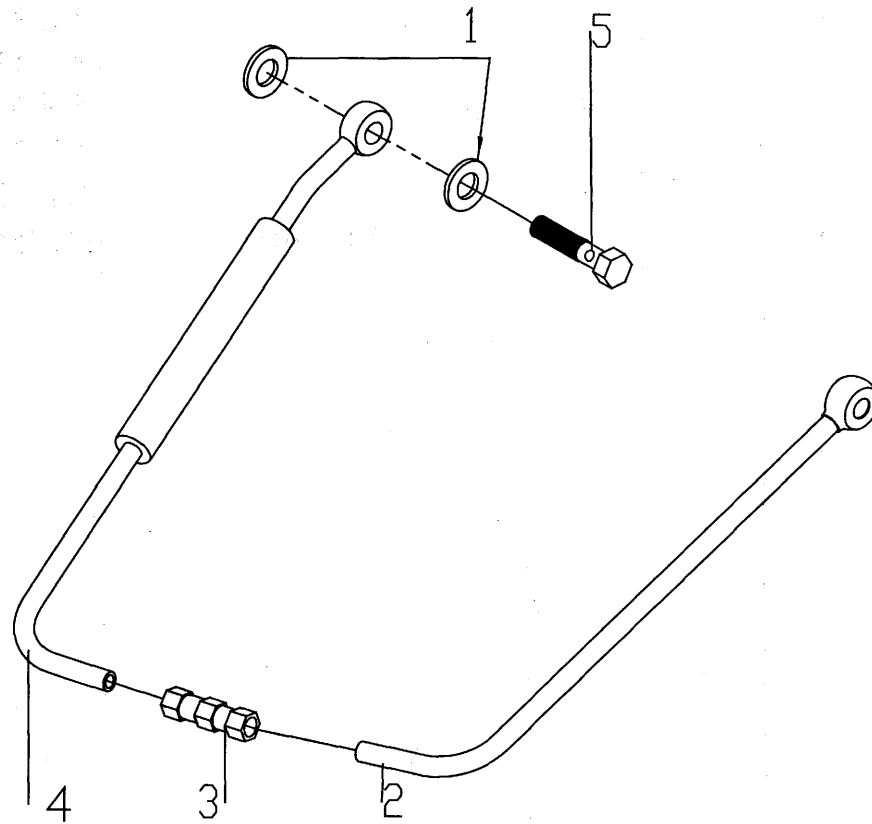

润滑油管总成二 OIL SUCTION LINE ASSEMBLY(二)

序号 Pos.	图号 Teile. Number	组别 Sort	柴油机设计号 (件数) Engine SN Stk.				规格标准 DIN/Fremdfabr. Nr.	中文名称 Denomination	英文名称 Designation
			13020109	13020107	13020106	13020088			
1	13023358	05	2	2	2	2	D6M - STH3102	密封垫圈	SEALING RING
2	13020438	16	1	1				润滑油管	LUBRICAT. OIL LINE
2	12188188	16			1	1		润滑油管	LUBRICAT. OIL LINE
3	13021772	16	1	1	1	1		卡套式直通管接头	THREDED JOINT
4	12187856	16	1	1	1	1		润滑油管	LUBRICAT OIL LINE
5	01153236	05	1	1	1	1	空心螺栓	HOLLOW SCREW	

高压油泵总成 FUEL INJECTION PUMP ASSEMBLY

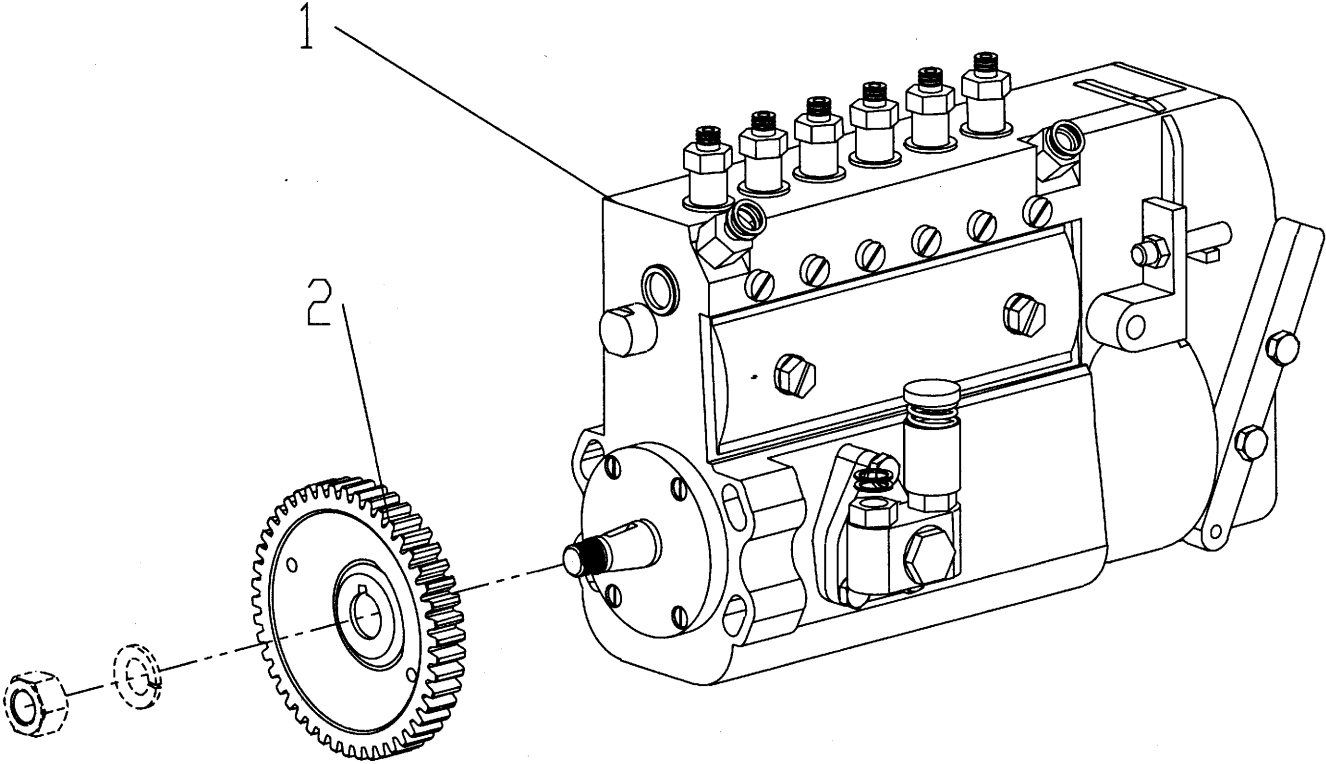

高压油泵总成 FUEL INJECTION PUMP ASSEMBLY

序号 Pos.	图号 Teile. Number	组别 Sort	柴油机设计号 (件数) Engine SN Stk.				规格标准 DIN/Fremdfabr. Nr.	中文名称 Denomination	英文名称 Designation
			13020109	13020107	13020106	13020088			
1	13020436	17	1				喷油泵分总成	FUEL INJECTION PUMP	
1	13021656			1			喷油泵分总成	FUEL INJECTION PUMP	
1	13022000				1		喷油泵分总成	FUEL INJECTION PUMP	
1	13022387					1	喷油泵分总成	FUEL INJECTION PUMP	
2	13023016	17	1				喷油泵传动齿轮	SPUR GEAR	
2	12159535	17		1	1		喷油泵传动齿轮	SPUR GEAR	

喷油器总成 FUEL INJECTOR ASSEMBLY

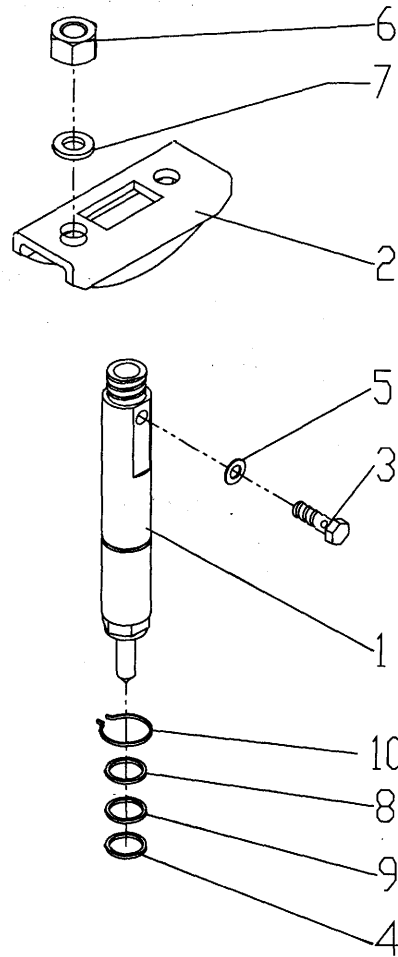

喷油器总成 FUEL INJECTOR ASSEMBLY

序号 Pos.	图号 Teile. Number	组别 Sort	柴油机设计号 (件数) Engine SN Stk.				规格标准 DIN/Fremdfabr. Nr.	中文名称 Denomination	英文名称 Designation
			13020109	13020107	13020106	13020088			
1	12153057	19	6			3	喷油器	FUEL INJECTOR	
1	12270162	19		4	3		喷油器	FUEL INJECTOR	
2	12159720	19	6	4	3	3	固定架	RETAINER	
3	12151817	05	6	4	3	3	空心螺栓	HOLLOW SCREW	
4	01222774	05	6	4	3	3	A9.5 * 20 * 2 - WEN11014 密封垫圈	SEALING RING	
5	01118641	05	12	8	6	6	A6 - 10 - Cu - DIN7603 密封垫圈	SEALING RING	
6	01112829	02	12	8	6	6	Q360B08 六角螺母	HEXAGON NUT	
7	01132562	1	12	8	6	6	Q40108 平垫片	PLAIN WASHER	
8	12159473	19	6	4	3	3	垫片	PLAIN WASHER	
9	06214701	27	6	4	3	3	20 * 3NBR - 1 - 70H2927 O型密封圈	O - SEAL	
10	01107731	73	6	4	3	3	Q43121 轴用弹性档圈	CIRCLIP	

13020109 燃油滤清器总成 FUEL FILTER ASSEMBLY

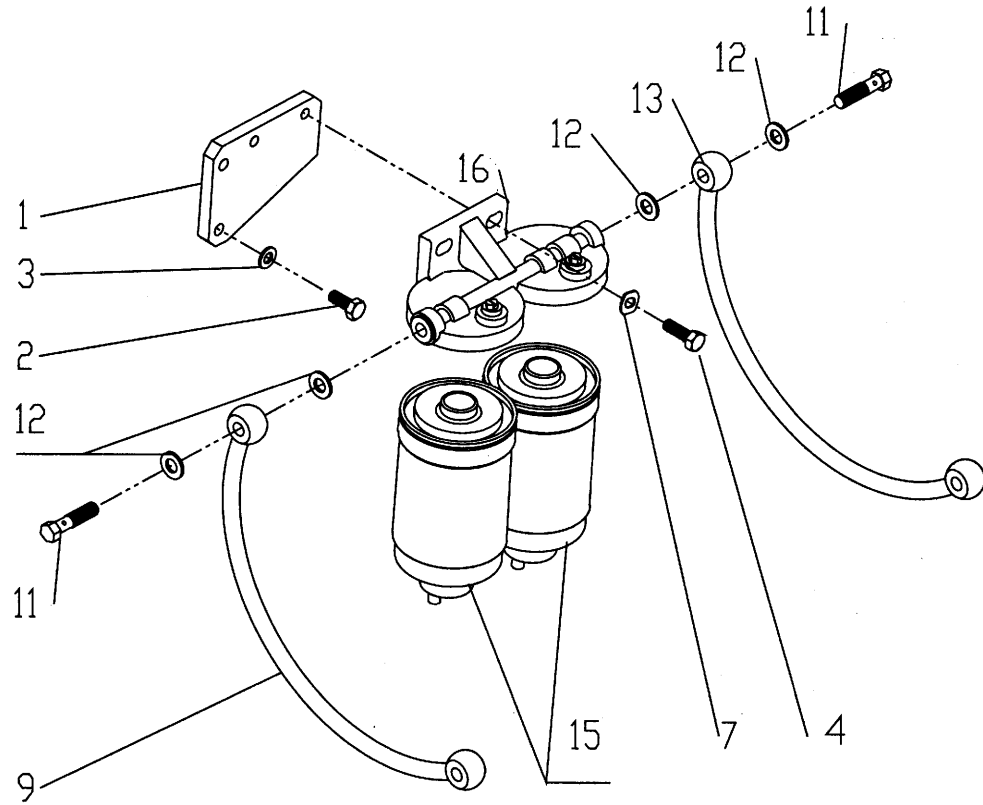

燃油滤清器总成 FUEL FILTER ASSEMBLY

序号 Pos.	图号 Teile. Number	组别 Sort	柴油机设计号 (件数) Engine SN Stk.				规格标准 DIN/Fremdfabr. Nr.	中文名称 Denomination	英文名称 Designation
			13020109	13020107	13020106	13020088			
1	13021409	20	1				燃油滤清器支架	BRACKET	
2	01137083	07	2			Q150B0820	六角头螺栓	HEXAGON BOLT	
3	01177981	01	2			Q40308	弹簧垫圈	SPRING LOCK WASHER	
4	01112416	07	2			Q150B1025	六角头螺栓	HEXAGON BOLT	
7	01107284	20	2			Q41810	波形弹性垫圈	SPRING LOCK WASHER	
9	12187737	20	1				软管	PIPE/LINE/LEAD	
11	01119243	02	2			D10M - STH3102	空心螺栓	HOLLOW SCREW	
12	13023360	05	4			14JB982	组合密封垫圈	SEALING RING	
13	13022577	90	1				软管	PIPE/LINE/LEAD	
15	13020488	20	2				燃油滤清器	FILTER CARTRIDGE	
16	13020489	20	1				滤座	FILTER HEAD	

13020107
13020106
13020088

燃油滤清器总成 FUEL FILTER ASSEMBLY

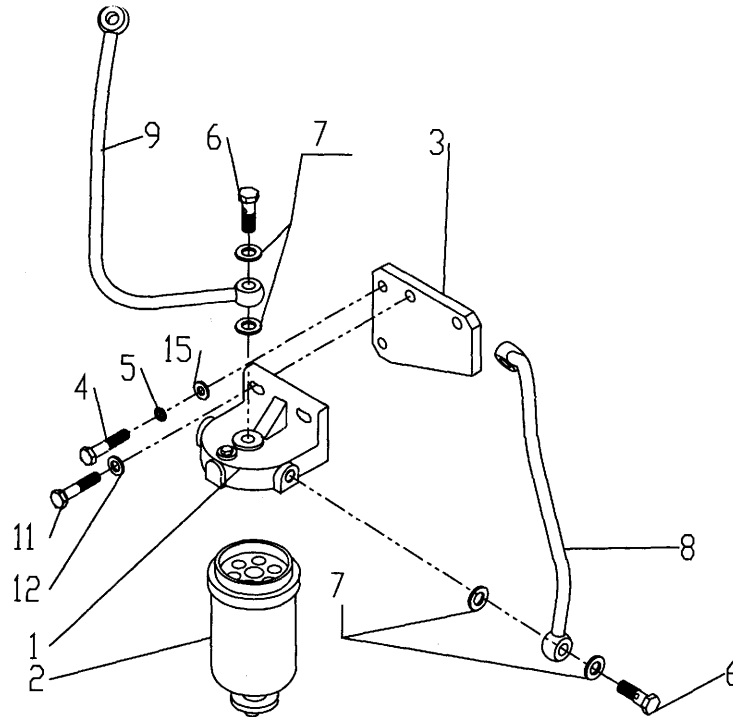

燃油滤清器总成 FUEL FILTER ASSEMBLY

序号 Pos.	图号 Teile. Number	组别 Sort	柴油机设计号 (件数) Engine SN Stk.				规格标准 DIN/Fremdfabr. Nr.	中文名称 Denomination	英文名称 Designation
			13020109	13020107	13020106	13020088			
1	12270391	20		1	1	1		滤座	FILTER HEAD
2	12270392	20		1	1	1		燃油滤清器	FILTER CARTRIDGE
3	13021409	20		1	1	1		燃油滤清器支架	BRACKET
4	01137083	07		2	2	2	Q150B0820	六角头螺栓	HEXAGON BOLT
5	01177981	01		2	2	2	Q40308	弹簧垫圈	SPRING LOCK WASHER
6	01119243	02		2	2	2	D10M - STH3102	空心螺栓	HOLLOW SCREW
7	13023360	05		4	4	4	14JB982	组合密封垫圈	SEALING RING
8	13023195	90		1	1	1		软管	PIPE/LINE/LEAD
9	13022577	90		1	1	1		软管	PIPE/LINE/LEAD
11	01112405	07		2	2	2	Q150B1020	六角头螺栓	HEXAGON BOLT
12	01152752	01		2	2	2	Q40110	平垫圈	GASKET
15	02404201	01		2	2	2		垫片	PLAN WASHER

13020109

高压油管总成 HIGH PRESSURE PIPE ASSEMBLY

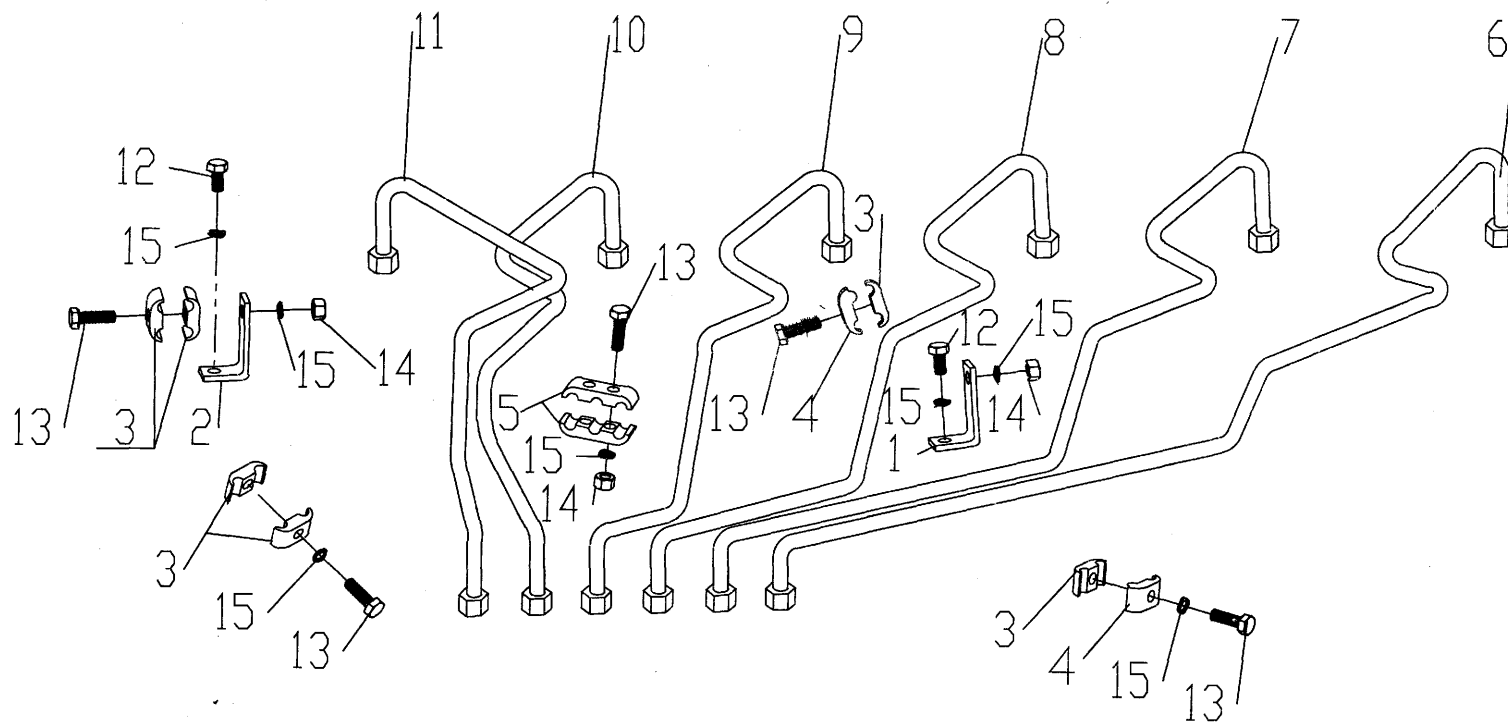

13020107

高压油管总成 HIGH PRESSURE PIPE ASSEMBLY

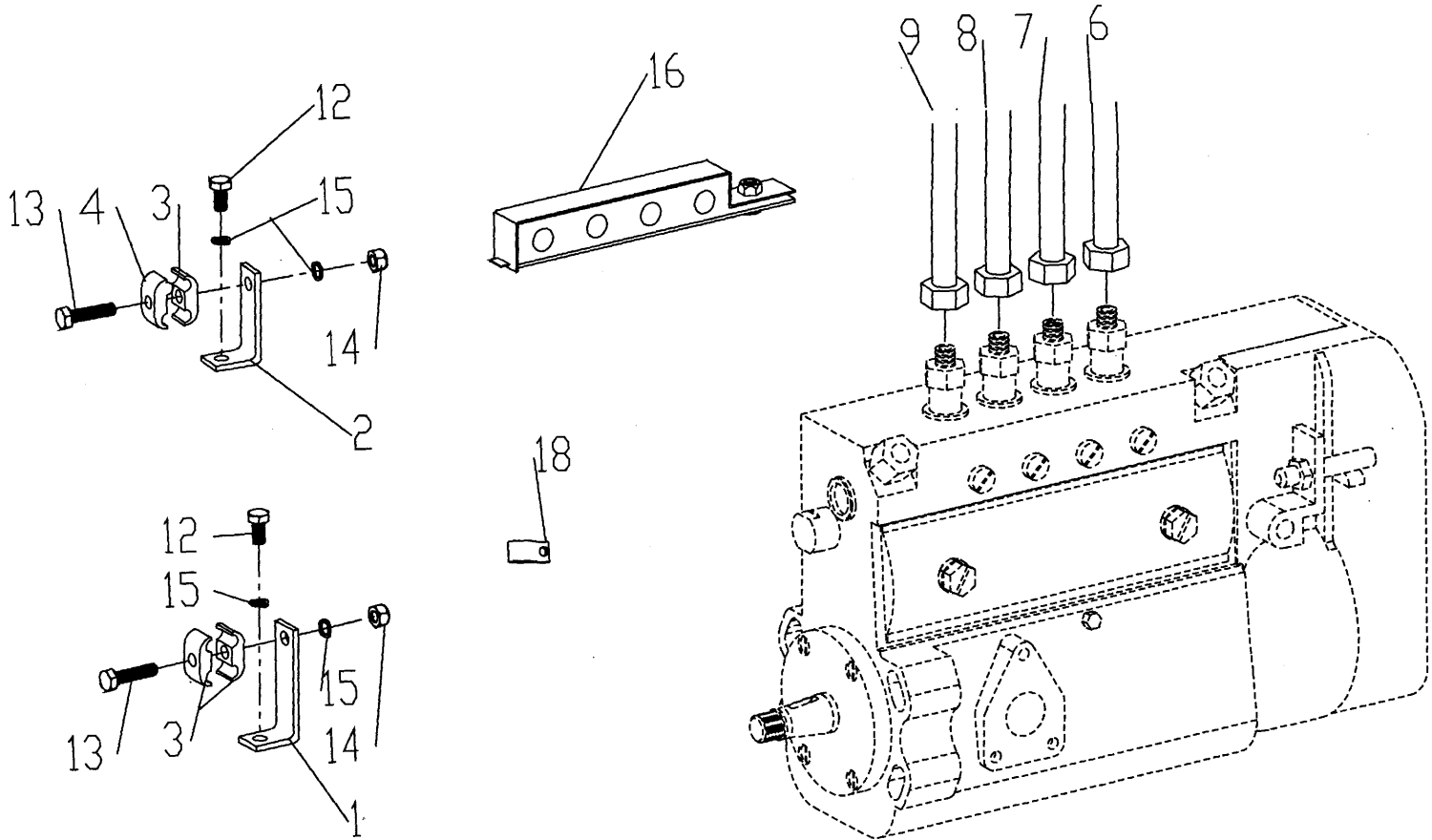

13020106

高压油管总成

13020088

HIGH PRESSURE PIPE ASSEMBLY

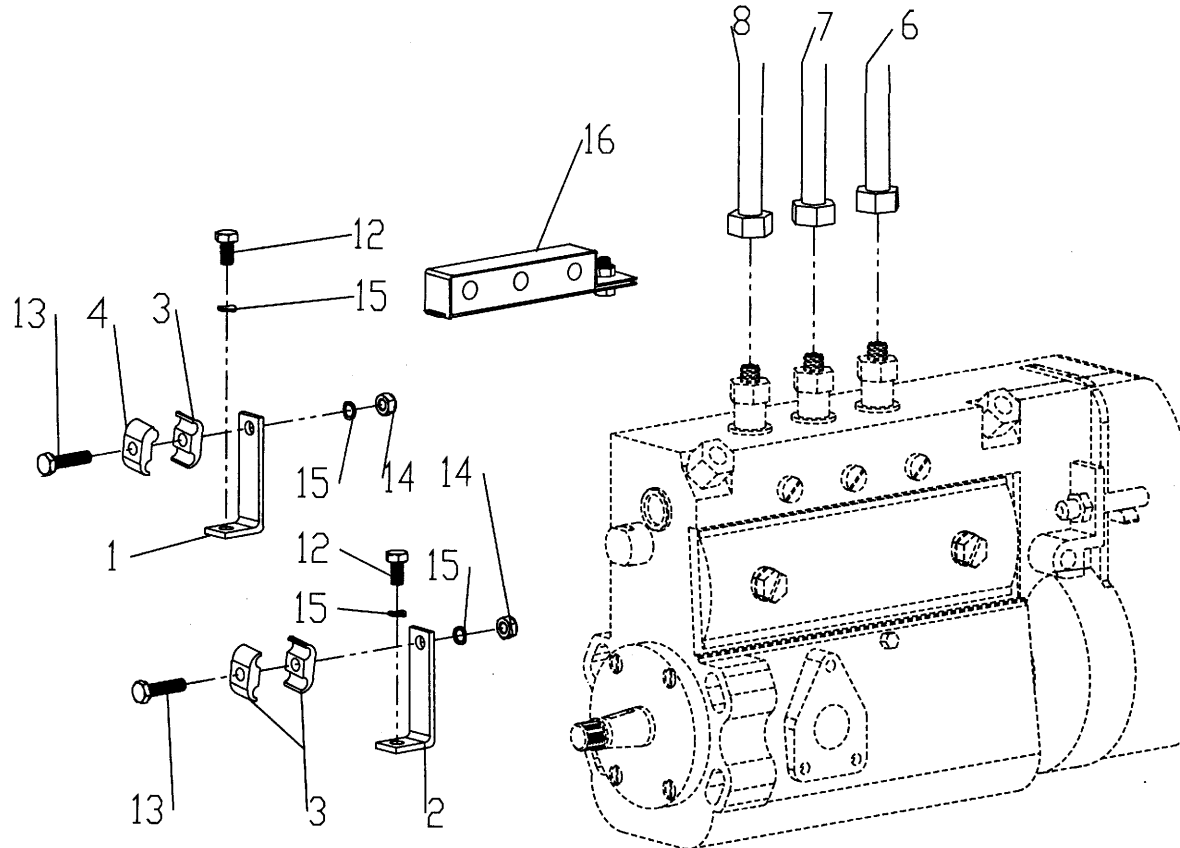

高压油管总成 HIGH PRESSURE PIPE ASSEMBLY

序号 Pos.	图号 Teile. Number	组别 Sort	柴油机设计号 (件数) Engine SN Stk.				规格标准 DIN/Fremdfabr. Nr.	中文名称 Denomination	英文名称 Designation
			13020109	13020107	13020106	13020088			
1	12272777	21	1	1	1	1		角架	ANGLE PLATE
2	12272776	21	4	2	1	1		角架	ANGLE PLATE
3	12165346	21	14	8	3	3		管夹(半)	HALF - CLIP
4	12166451	21	8	4	1	1		管夹(半)	HALF - CLIP
5	12158443	21	2					管夹	HALF - CLIP
6	13021319	21	1					高压油管	HIGH PRESSURE PIPE
6	12190644	21		1				高压油管	HIGH PRESSURE PIPE
6	13022410	21			1	1		高压油管	HIGH PRESSURE PIPE
7	13021320	21	1					高压油管	HIGH PRESSURE PIPE
7	12190592	21		1				高压油管	HIGH PRESSURE PIPE
7	13022411	21			1	1		高压油管	HIGH PRESSURE PIPE
8	13021321	21	1					高压油管	HIGH PRESSURE PIPE
8	12190593	21		1				高压油管	HIGH PRESSURE PIPE
8	13022412	21			1	1		高压油管	HIGH PRESSURE PIPE
9	13021322	21	1					高压油管	HIGH PRESSURE PIPE
9	12190594	21		1				高压油管	HIGH PRESSURE PIPE
10	13021323	21	1					高压油管	HIGH PRESSURE PIPE
11	13021324	21	1					高压油管	HIGH PRESSURE PIPE
12	01112238	21	5	3	2	2	Q150B0612	六角头螺栓	HEXAGON BOLT
13	01112267	21	13	6	2	2	Q150B0625	六角头螺栓	HEXAGON BOLT
14	01152783	21	8	3	2	2	Q360B06	六角螺母	HEXAGON NUT
15	01107279	21	18	9	4	4	Q41806	波形弹性垫圈	SPRING WASSHER
16	01176137	21		1			D1 - 4 * 6H3220	管夹	HALF - CLIP
16	01175776	21			1	1	D1 - 3 * 6H3220	管夹	HALF - CLIP
18	12156421	21		1			R244	管夹箍	CONNECTION

13020109

中间垫块总成 ADAPTER ASSEMBLY

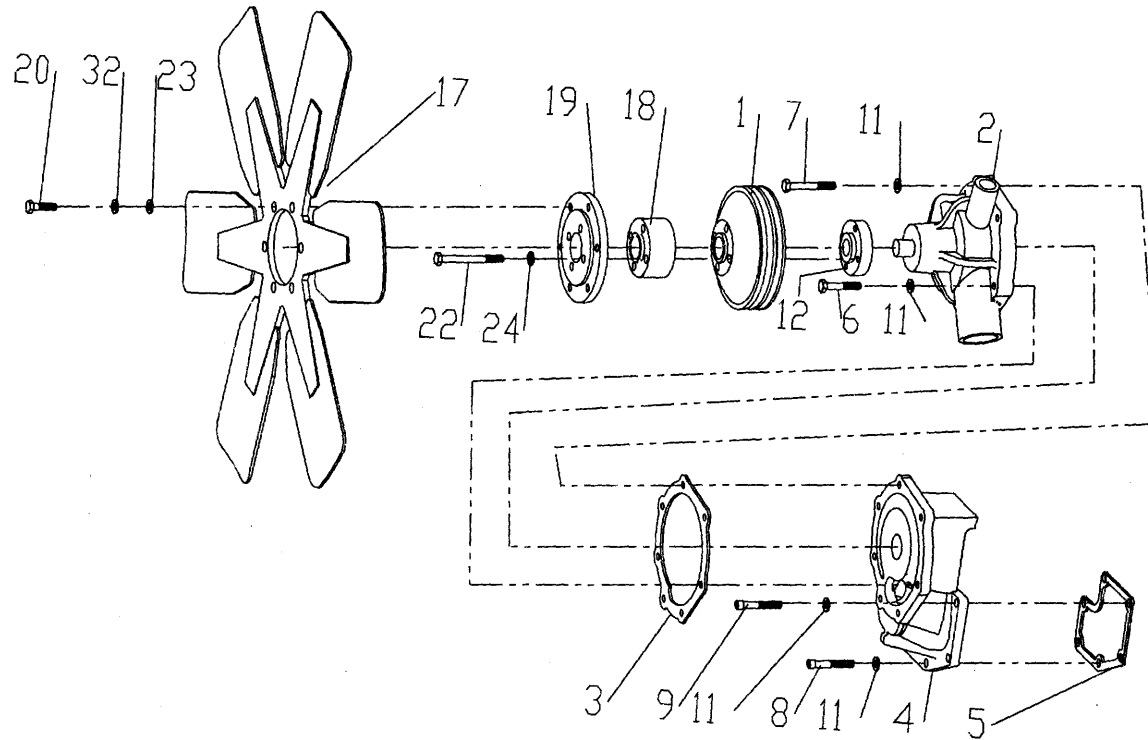

13020107
13020106
13020088

中间垫块总成 ADAPTER ASSEMBLY

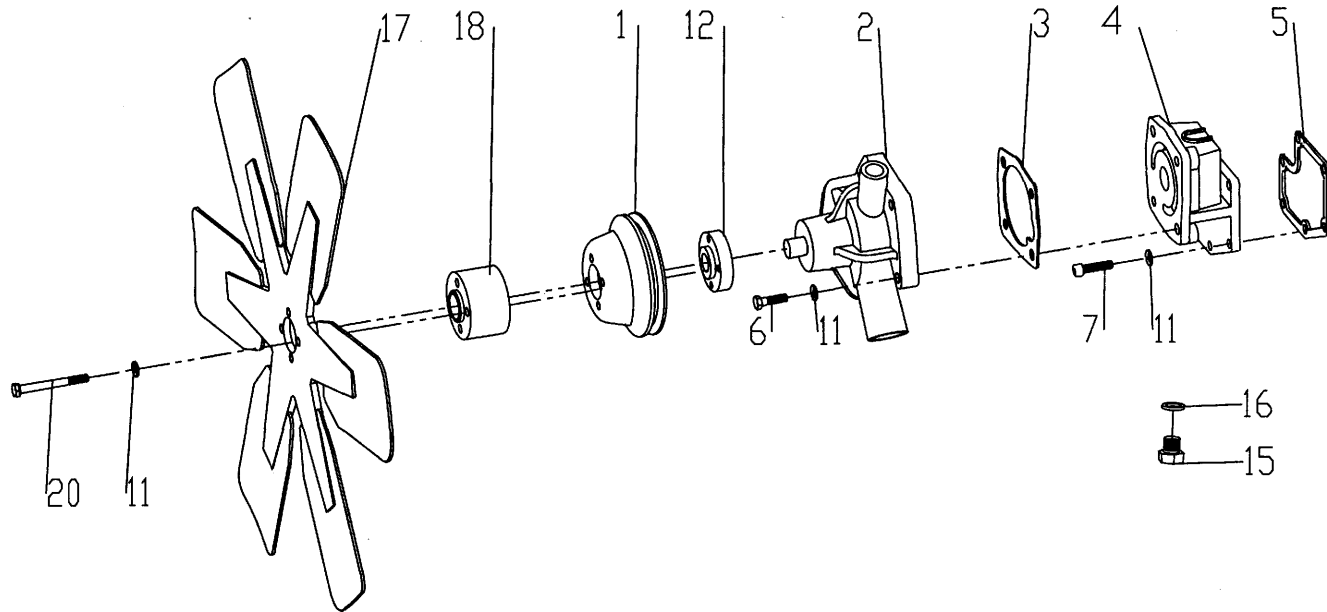

中间垫块总成 ADAPTER ASSEMBLY

序号 Pos.	图号 Teile. Number	组别 Sort	柴油机设计号 (件数) Engine SN Stk.				规格标准 DIN/Fremdfabr. Nr.	中文名称 Denomination	英文名称 Designation
			13020109	13020107	13020106	13020088			
1	12213366	37	1				水泵皮带轮	V - GROOVED PULLEY	
1	13020583	37		1	1	1	水泵皮带轮		
2	12159770	37	1				水泵总成	CENTRIFUGAL PUMP	
2	12273212	37		1	1	1	水泵总成		
3	12200650	37	1				水泵垫片	PUMP GASKET	
3	12270869	37		1	1	1			
4	12159708	37	1				中间垫块	ADAPTER	
4	13020587	37		1	1	1			
5	12158513	37	1	1	1	1	水泵垫片	PUMP GASKET	
6	01111151	37	5				Q150B0845 六角头螺栓	HEXAGON BOLT	
6	01139584	37		4	4	4	Q150B0835 六角头螺栓	HEXAGON BOLT	
7	01111166	37	2				Q150B0860 六角头螺栓	HEXAGON BOLT	
7	01112331	37		6	6	6	Q150B0825 六角头螺栓	HEXAGON BOLT	
8	01151500	37	4				M8 * 45 - 12.9GB70 内六角圆柱头螺钉	CHESS HEAD SCREW	
9	01152347	37	2				M8 * 50 - 12.9GB70 内六角圆柱头螺钉	CHESS HEAD SCREW	
11	01177981	37	17	14	14	14	Q40308 弹簧垫圈	SPRING LOCK WASHER	
12	12160552	37	1	1	1	1	轮毂	FLANGE	
15	01118960	37		1	1	1	AM14 * 1.5 - 5.8DIN7604 六角头螺塞	HEXAGON BOLT	
16	13023360	37		1	1	1	14JB982 组合密封垫圈	SEALING RING	
17	13021190	37	1				排风风扇	FAN	
17	13021367	37		1	1	1	排风风扇	FAN	
18	12159208	37	1				中间法兰	SHAPED FLANGE	
18	13024404	37		1	1	1	中间法兰	SHAPED FLANGE	

中间垫块总成 ADAPTER ASSEMBLY

序号 Pos.	图号 Teile. Number	组别 Sort	柴油机设计号 (件数) Engine SN Stk.				规格标准 DIN/Fremdfabr. Nr.	中文名称 Denomination	英文名称 Designation
			13020109	13020107	13020106	13020088			
19	13021193	37	1				中间法兰	SHAPED FLANGE	
20	01112405	37	6			Q150B1020	六角头螺栓	HEXAGON BOLT	
20	13024406	37		4	4	M8 * 100 - 10.9GB5782	六角头螺栓	HEXAGON BOLT	
21	13020581	37		1	1		水泵皮带轮垫块	ADAPTER	
22	13024408	37	4			M8 * 75 - 10.9GB5782	六角头螺栓	HEXAGON BOLT	
23	01152752	37	6			Q40110	垫片	GASKET	
24	01132562	37	4			Q40108	平垫片	GASKET	
32	01178365	37	6			Q40310	弹簧垫圈	SPRING LOCK WASHER	

13020109

进、排气系统一 AIR INTAKE EXHAUST SYSTEM(一)

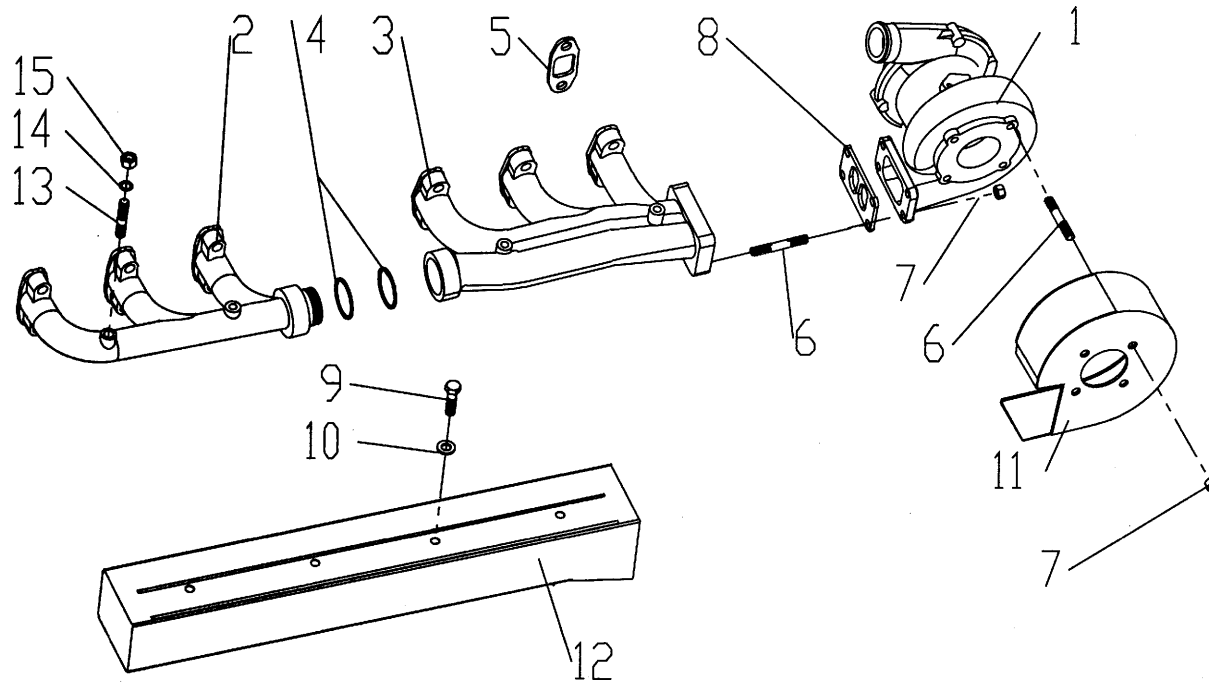

进、排气系统(一) AIR INTAKE EXHAUST SYSTEM(一)

序号 Pos.	图号 Teile. Number	组别 Sort	柴油机设计号 (件数) Engine SN Stk.				规格标准 DIN/Fremdfabr. Nr.	中文名称 Denomination	英文名称 Designation
			13020109	13020107	13020106	13020088			
1	12270137	43	1				废气涡轮增压器	TURBOCHAGER	
2	12188682	41	1			QT400 - 15 GB1348	排气管	EXHAUST PIPE	
3	13020728	41	1			QT400 - 15GB1348	排气管	EXHAUST PIPE	
4	12188619	41	4			0Cr15Ni25Ti2MoAlVB - GB1221	薄片环	SET OF SEALINGS	
5	12272783	41	6			1Cr18Ni9 - 0.3 * 100 - R - Q - K - GB4239	排气管垫片	GASKET	
6	01143285	41	4			25Cr2MoVAGB3077	双头螺柱	DOUBLE - STUD	
7	01321459	41	4			25Cr2MoVAGB3077	防松螺母	HEXAGON NUT	
8	12161833	41	1				密封垫	GASKET	
9 *	13021725	41	6				六角头螺栓	HEXAGON BOLT	
10 *	12163182	41	4				垫片	PLAIN WASHER	
11 *	13024151	43	1				增压器罩	TURBOCHAGER COVER	
12 *	13025424	41	1				排气管罩	EXHAUST PIPE COVER	
13	01143285	41	2				双头螺柱	DOUBLE - STUD	
14	01143285	41	4				平垫圈	PLAIN WASHER	
15	01153252	41	2				六角螺母	HEXAGON NUT	

* 为 CE 认证 226B 柴油机用

13020109

进、排气系统二 AIR INTAKE EXHAUST SYSTEM(二)

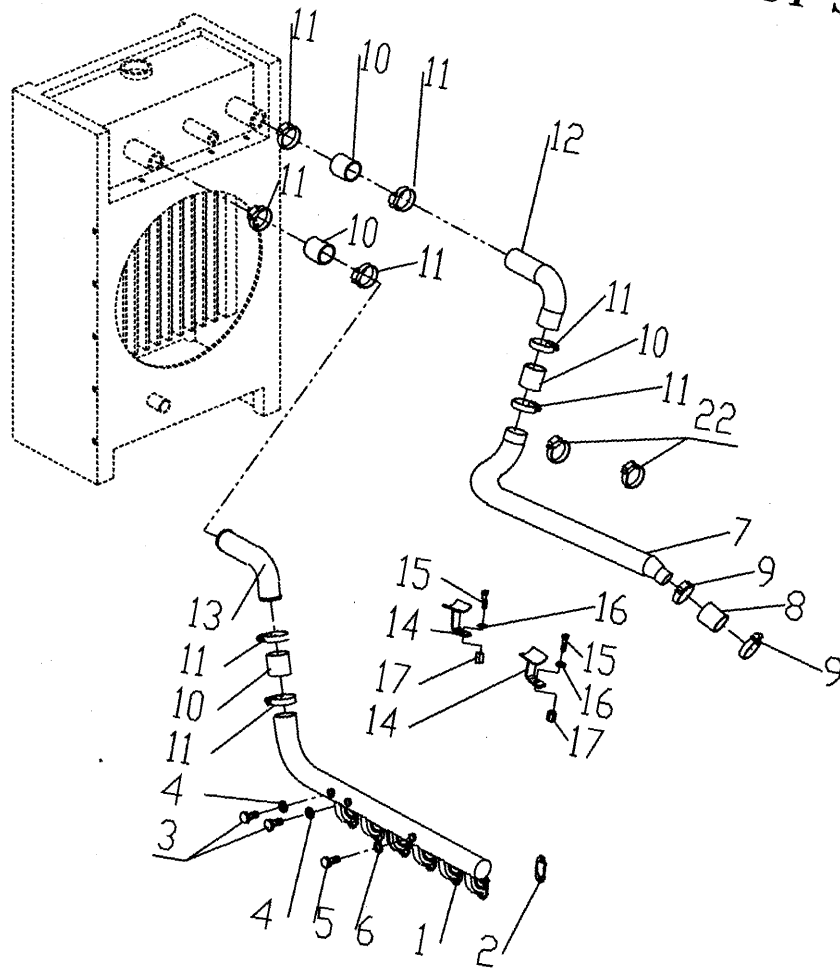

进、排气系统(二) AIR INTAKE EXHAUST SYSTEM(二)

序号 Pos.	图号 Teile. Number	组别 Sort	柴油机设计号 (件数) Engine SN Stk.				规格标准 DIN/Fremdfabr. Nr.	中文名称 Denomination	英文名称 Designation
			13020109	13020107	13020106	13020088			
1	13021885	22	1				进气管	INTAKE	
2	12272783	22	6				垫片	PLAN WASHER	
3	01125789	22	2			M20 * 1.5 - 5.8 DIN910	六角头螺塞	HEXAGON NUT	
4	01118727	22	2			A20 * 24 - Cu DIN7603	密封垫圈	SEALING RING	
5	01152105	22	1			AM12 * 1.5 - 5.8 DIN7604	六角头螺塞	HEXAGON BOLT	
6	01118681	22	1			A12 * 18 - Cu DIN7604	密封垫圈	SEALING RING	
7	13021886	22	1				增压器空气管	TUBING AIR PIPE	
8	01175634	22	1				橡胶软管	TUBE	
9	01133878	22	2			Q67560	软管卡箍	CLIP	
10	12200644	22	4				增压空气软管	TUBE	
11	12151677	22	8			Q67590	软管卡箍	CLIP	
12	13021888	22	1				中冷器进气管	AIR COOLING INTAKE PIPE	
13	13021889	22	1				中冷器出气管	AIR COOLING EXHAUST PIPE	
14	12190327	22	2				支架	BRACKET	
15	01152414	22	2			Q150B1425	六角头螺栓	HEXAGON BOLT	
16	01154441	22	2				垫片	PLAIN WASHER	
17	12159523	22	2				螺母	HEXAGON NUT	
22	12200642	22	2				软管卡箍	CLIP	

13020107

进、排气系统总成 AIR INEAKE EXHAUST SYSTEM ASSEMBLY

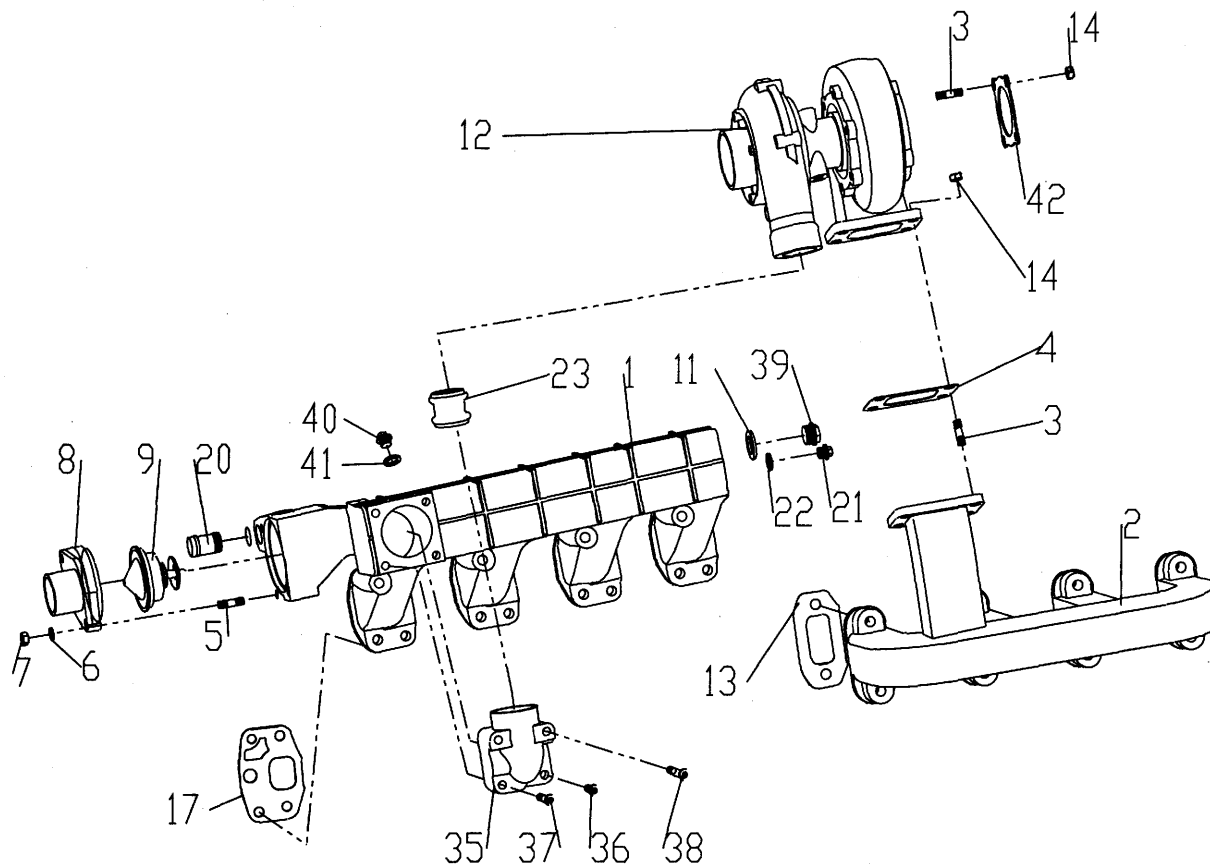

进、排气系统总成 AIR INEAKE EXHAUST SYSTEM ASSEMBLY

序号 Pos.	图号 Teile. Number	组别 Sort	柴油机设计号 (件数) Engine SN Stk.				规格标准 DIN/Fremdfabr. Nr.	中文名称 Denomination	英文名称 Designation
			13020109	13020107	13020106	13020088			
1	12272225	22		1			进气管组件	INTAKE	
2	12272232	41		1			排气管	EXHAUST PIPE	
3	01153347	41		8		M8 * 20 - 12.9GB898	双头螺栓	DOUBLE - BOLT	
4	13020718	41		1			垫片	PLAN WASHER	
5	01151397	41		2		M8 * 30 - 8.8GB900 - HY	双头螺栓	DOUBLE - BOLT	
6	01177981	41		2		Q40308	弹簧垫圈	SPRING LOCK WASHER	
7	01112829	41		2		Q360B08	六角螺母	HEXAGON NUT	
8	12270944	22		1			节温器盖	THERMOSTAT COVER	
9	13021132	22		1			节温器	THERMOSTAT	
11	00111873	22		1		A22 * 27 - CuDIN7603	密封垫圈	GASKET	
12	13021659	43		1			增压器	TURBOCHAGER	
13	12272783	41		4			排气管垫片	PLAN WASHER	
14	01321455	41		8		Q33208	自锁螺母	HEXAGON NUT	
17	12190460	22		4			进气管垫片	PLAN WASHER	
20	12188750	8		1			管接头	PIPE - JOINT	
21	01152105	22		1		AM12 * 1.5 - 5.8DIN7604	六角头螺塞	HEXAGON SCREW PLUG	
22	01118681	22		1		Q617B12	密封垫片	GASKET	
23	12272668	22		1			连接管	CONNECT - PIPE	
35	12272195	22		1			增压空气弯管	SYPHON	
36	01110571	22		1		M8 * 25 - 12.9GB70	内六角圆柱头螺钉	CHESS HEAD SCREW	
37	01151504	22		1		M8 * 55 - 12.9GB70	内六角圆柱头螺钉	CHESS HEAD SCREW	
38	01110610	22		2		M8 * 70 - 12.9GB70	内六角圆柱头螺钉	CHESS HEAD SCREW	

进、排气系统总成 AIR INEAKE EXHAUST SYSTEM ASSEMBLY

序号 Pos.	图号 Teile. Number	组别 Sort	柴油机设计号 (件数) Engine SN Stk.				规格标准 DIN/Fremdfabr. Nr.	中文名称 Denomination	英文名称 Designation
			13020109	13020107	13020106	13020088			
39	13021317	22		1			LD10GB3190	六角头螺塞	SCREW PLUG
40	01118960	22		3			AM14 * 1.5 - 5.8DIN7604	六角头螺塞	HEXAGON SCREW PLUG
41	13023360	22		3			14JB982	组合密封垫圈	GASKET
42	13021401	71		1				垫片	PLAN WASHER

13020106

进、排气系统总成 AIR INTAKE EXHAUST SYSTEM ASSEMBLY

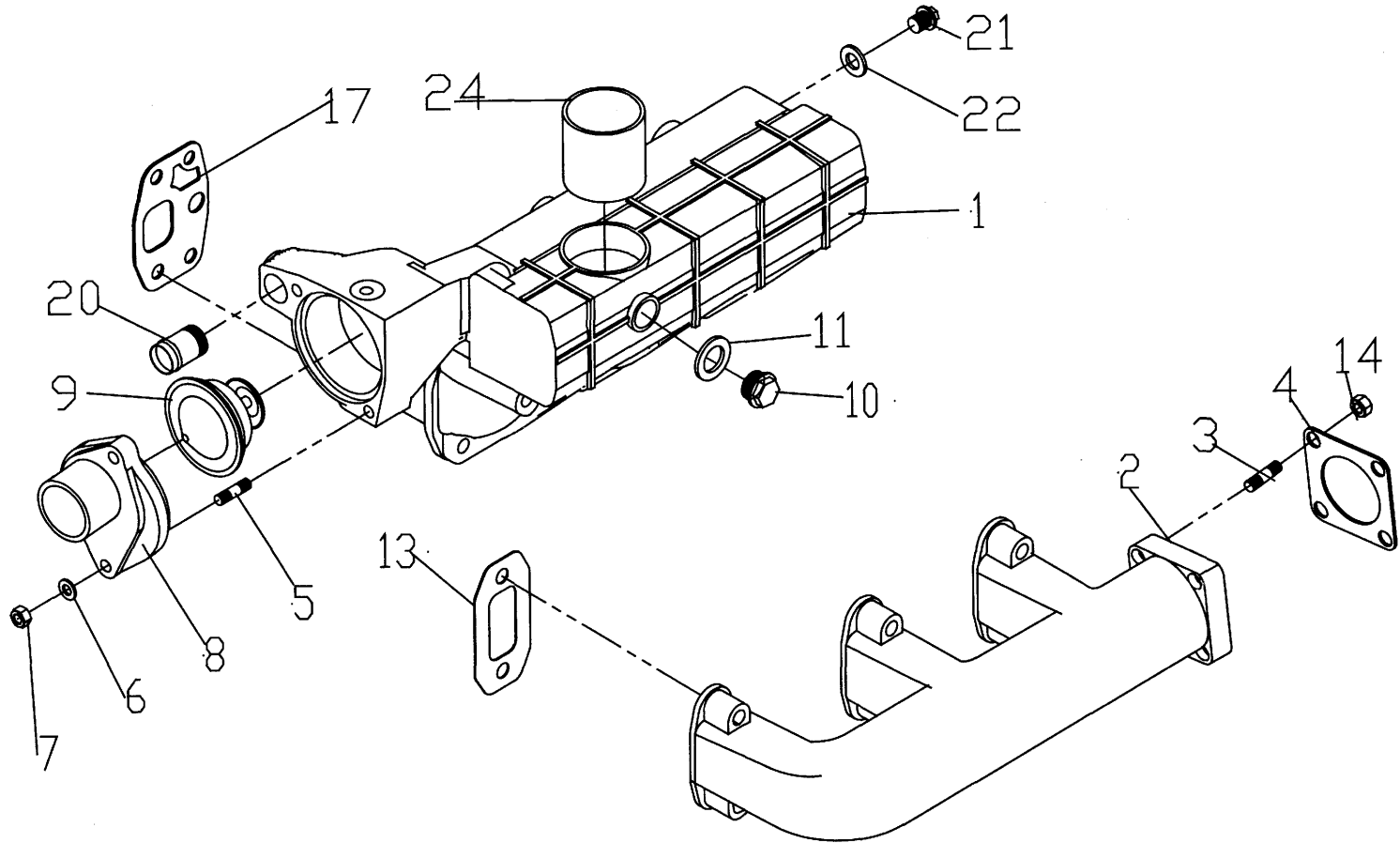

13020088

进、排气系统总成 AIR INTAKE EXHAUST SYSTEM ASSEMBLY

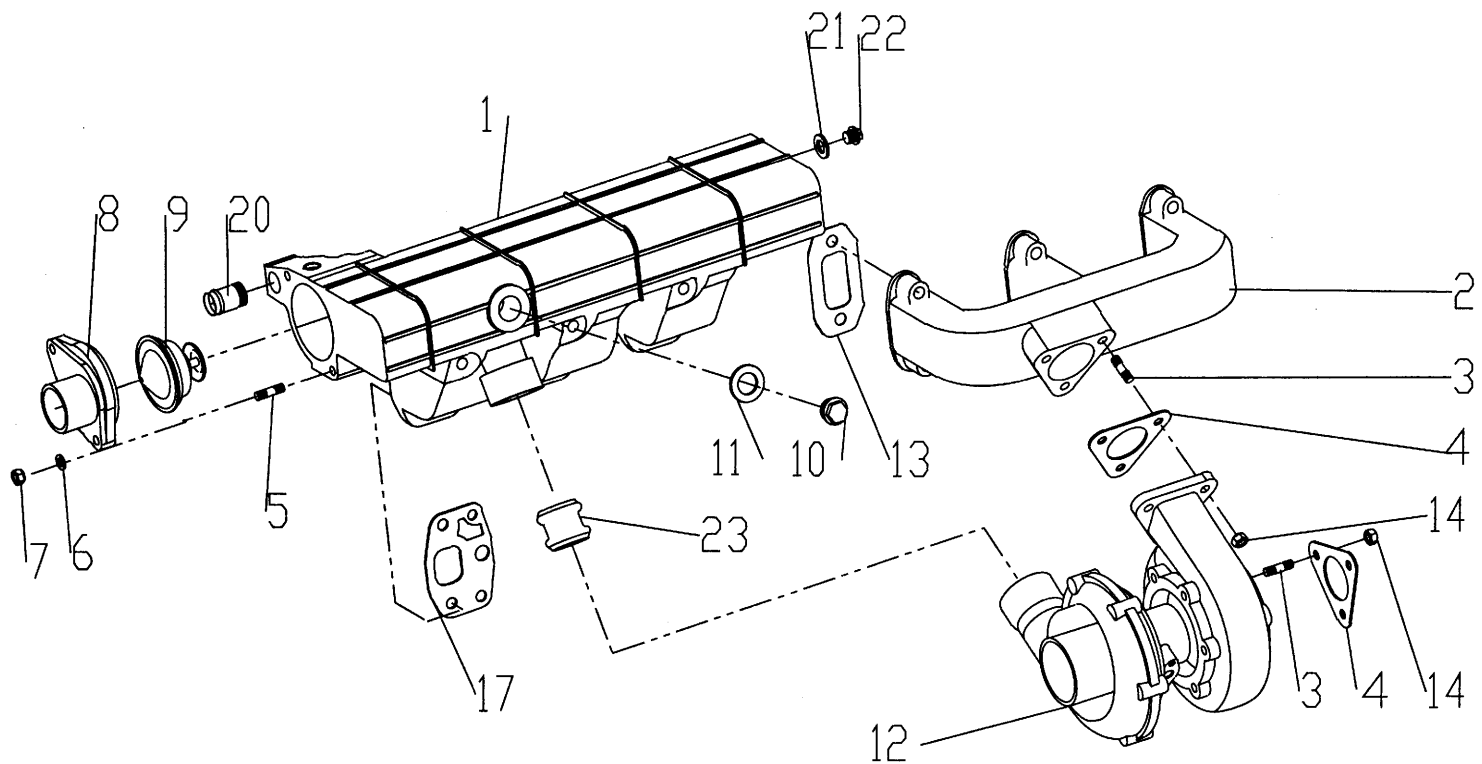

进、排气系统 AIR INTAKE EXHAUST SYSTEM

序号 Pos.	图号 Teile. Number	组别 Sort	柴油机设计号 (件数) Engine SN Stk.				规格标准 DIN/Fremdfabr. Nr.	中文名称 Denomination	英文名称 Designation
			13020109	13020107	13020106	13020088			
1	13021851	22			1		进气管组件	INTAKE PIPE	
1	12190703	22				1	进气管组件	INTAKE PIPE	
2	13024837	41			1		排气管	EXHAUST PIPE	
2	12191084	41				1	排气管	EXHAUST PIPE	
3	01143285	41			4	M10 * 25 - 12.9GB898	双头螺柱	DOUBLE - BOLT	
3	01153347	41				6	M8 * 20 - 12.9GB898	双头螺柱	DOUBLE - BOLT
4	13022028	41			1		垫片	PLAIN WASHER	
4	13022165	41				2		垫片	PLAIN WASHER
5	01151397	41			2	2	M8 * 30 - 8.8GB900HY	双头螺柱	DOUBLE - BOLT
6	01177981	41			2	2	Q40308	弹簧垫圈	SPRING LOCK WASHER
7	01112829	41			2	2	Q360B08	六角螺母	HEXAGON NUT
8	12270944	22			1	1		节温器盖	THERMOSTAT COVER
9	13021132	22			1	1		节温器	THERMOSTAT
10	01125789	22			1	1	M20 * 1.5 - 5.8 - DIN910	六角头螺塞	SCREW PLUG
11	01118730	22			1	1	A20 * 26 - Cu DIN7603	密封垫圈	SEALING RING
12	12270783	43				1		增压器	TURBOCHAGER
13	12272783	41			3	3		垫片	PLAIN WASHER
14	13021455	41			4	6		自锁螺母	HEXAGON NUT
17	12190460	41			3	3		进气管垫片	PLAIN WASHER
20	12188750	41			1	1		管接头	PIPE - JOINT
21	13021317	41			1		Q617B22	六角头螺塞	SCREW PLUG
21	01152105	41				1	AM12 * 1.5 - 5.8DIN7604	六角头螺塞	SCREW PLUG

进、排气系统 AIR INTAKE EXHAUST SYSTEM

序号 Pos.	图号 Teile. Number	组别 Sort	柴油机设计号 (件数) Engine SN Stk.				规格标准 DIN/Fremdfabr. Nr.	中文名称 Denomination	英文名称 Designation
			13020109	13020107	13020106	13020088			
22	01118737	41			1		A22 * 2.7 - CuDIN7603	密封垫圈	SEALING RING
22	01118681	41				1	A12. * 1.8 - CuDIN7603	密封垫圈	SEALING RING
23	12272592	41				1		连接管	CONNECT - PIPE

13020109

空滤器总成 AIR FILTER ASSEMBLY

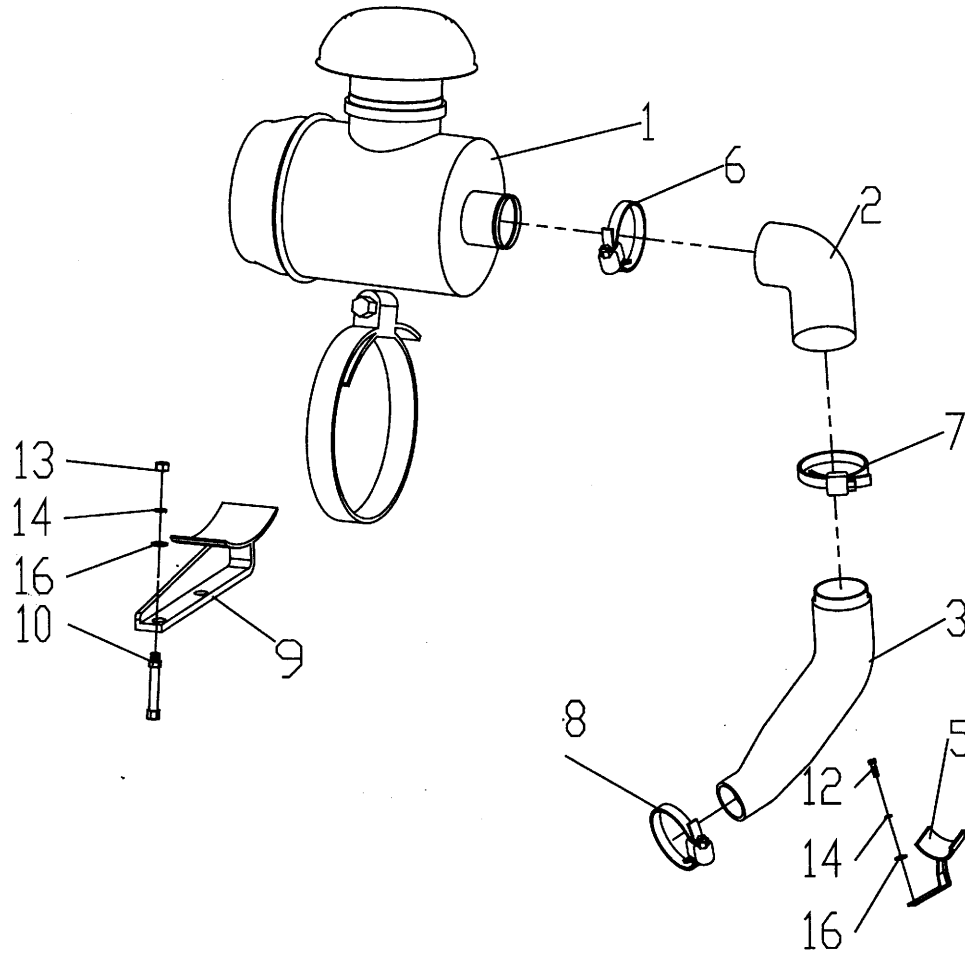

空滤器总成 AIR FILTER ASSEMBLY

序号 Pos.	图号 Teile. Number	组别 Sort	柴油机设计号 (件数) Engine SN Stk.				规格标准 DIN/Fremdfabr. Nr.	中文名称 Denomination	英文名称 Designation
			13020109	13020107	13020106	13020088			
1	13024892	22	1				空气滤清器	AIR FILTER	
2	13021853	22	1				橡胶弯管	TUBE	
3	13024754	22	1				橡胶弯管	TUBE	
5	13021855	22	1				橡胶管支架	BRACKET	
6	13021569	22	1			Q675140	卡箍	CLIP	
7	13021568	22	3			Q675120	卡箍	CLIP	
8	12151677	22	1			Q67590	卡箍	CLIP	
9	13022519	22	2			钢板6-GB709/20-GB710	空气滤清器支架	BRACKET	
10	13020714	22	4			热轧圆钢	连接螺栓	HEXAGON BOLT	
12	01112416	22	2			Q150B1025	六角头螺栓	HEXAGON BOLT	
13	01139401	22	4			Q360B10	六角螺母	HEXAGON NUT	
14	01178365	22	6			Q40310	弹簧垫圈	SPRING LOCK WASHER	
16	01152752	22	6			Q40110	平垫圈	PLAIN WASHER	

13020107

空滤器总成 AIR FILTER ASSEMBLY

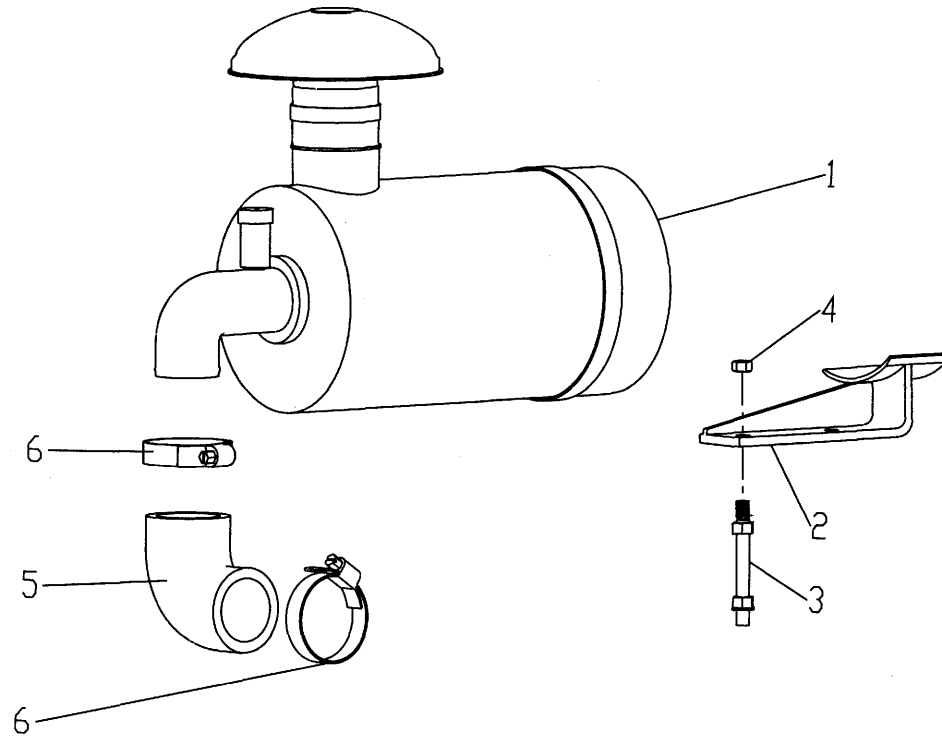

空滤器总成 AIR FILTER ASSEMBLY

序号 Pos.	图号 Teile. Number	组别 Sort	柴油机设计号 (件数) Engine SN Stk.				规格标准 DIN/Fremdfabr. Nr.	中文名称 Denomination	英文名称 Designation
			13020109	13020107	13020106	13020088			
1	13022962	22		1			空滤器	AIR FILTER	
2	13022959	22		1			空滤器支架	BRACKET	
3	13022462	22		2			连接螺栓	HEXAGON BOLT	
4	01143995	22		2			螺母	HEXAGON NUT	
5	13022961	22		1			进气弯管	SYPHON	
6	12151677	22		2		A67570	卡箍	CLIP	

13020106
13020088

空滤器总成 AIR FILTER ASSEMBLY

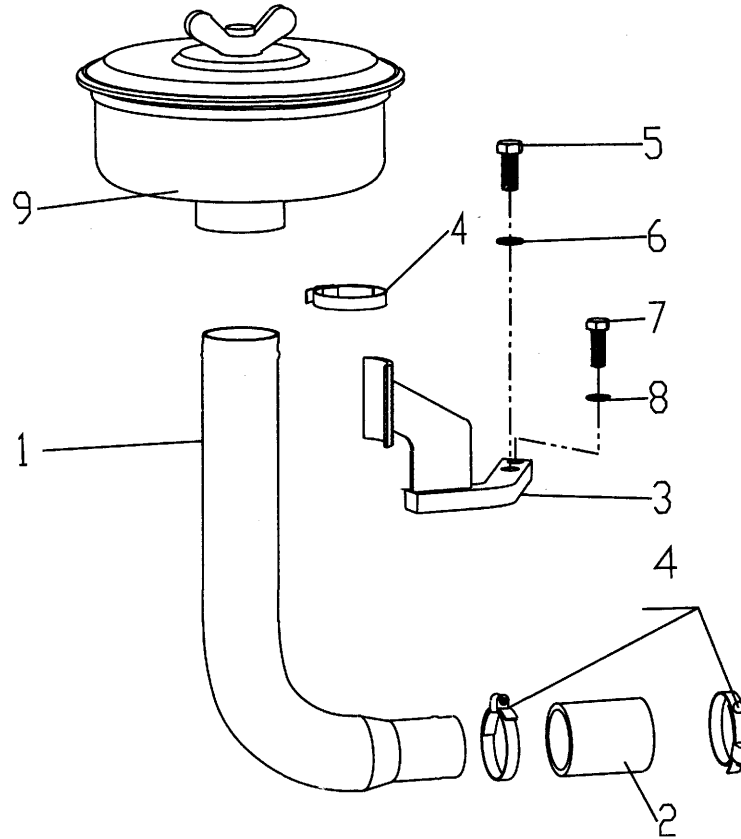

空滤器总成 AIR FILTER ASSEMBLY

序号 Pos.	图号 Teile. Number	组别 Sort	柴油机设计号 (件数) Engine SN Stk.				规格标准 DIN/Fremdfabr. Nr.	中文名称 Denomination	英文名称 Designation
			13020109	13020107	13020106	13020088			
1	13022216	22				1		增压器进气管	TUBING AIR PIPE
2	13022215	22				1		橡胶软管	TUBE
3	13022218	22				1		空滤器支架	BRACKET
4	01133878	22				3		软管卡箍	CLIP
5	01151548	22				1	Q150B1230	六角头螺栓	HEXAGON BOLT
6	01178365	22				3	Q40310	弹簧垫圈	SPRING LOCK WASHER
7	01112427	22				1	Q150B1030	六角头螺栓	HEXAGON BOLT
8	01151548	22				1	Q40312	弹簧垫圈	SPRING LOCK WASHER
9	13022026	22			1	1		空滤器总成	AIR FILTER

13020109

消音器总成 SILENCER ASSEMBLY

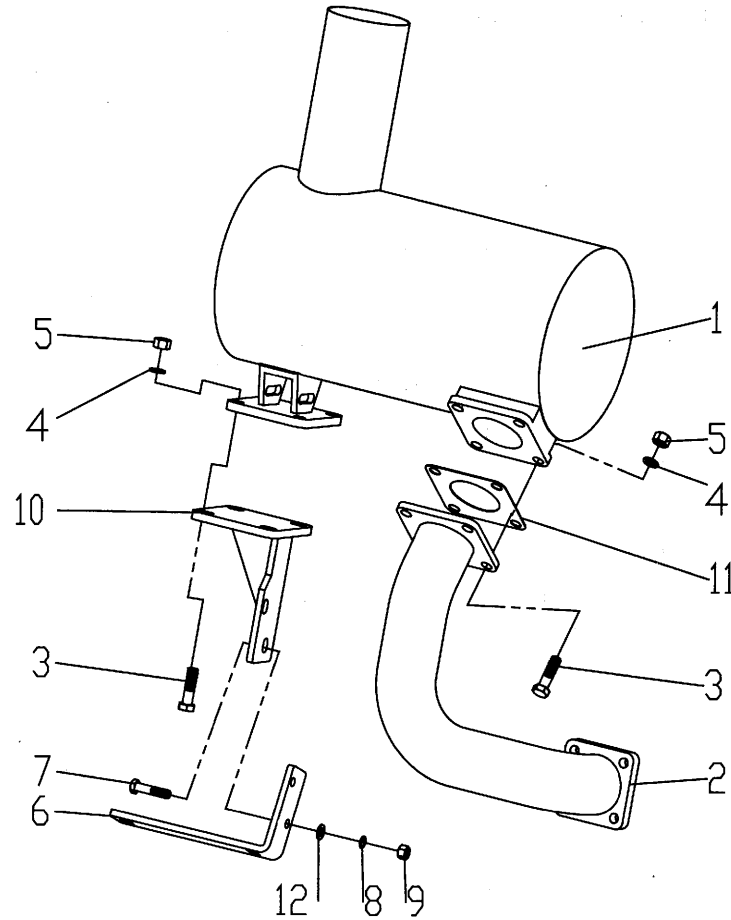

消音器总成 SILENCER ASSEMBLY

序号 Pos.	图号 Teile. Number	组别 Sort	柴油机设计号 (件数) Engine SN Stk.				规格标准 DIN/Fremdfabr. Nr.	中文名称 Denomination	英文名称 Designation
			13020109	13020107	13020106	13020088			
1	13021578	71	1				消音器	SILENCER	
2	13024751	71	1				排气接管	EXHAUST PIPE	
3	01151549	71	8			M12 * 35 - 8.8GB5782	六角头螺栓	HEXAGON BOLT	
4	01178366	71	8			Q40312	弹簧垫圈	SPRING LOCK WASHER	
5	01112861	71	8			Q360B12	六角螺母	HEXAGON NUT	
6	13024752	71	1				消音器支架	SILENCER BRACKET	
7	01112437	71	2			Q150B1035	六角头螺栓	HEXAGON BOLT	
8	01178365	71	2			Q40310	弹簧垫圈	SPRING LOCK WASHER	
9	01139401	71	2			Q360B10	六角螺母	HEXAGON NUT	
10	13021547	71	1				消音器支架	SILENCER BRACKET	
11	13021580	71	1				密封垫片	SEALING RING	
12	01152752	71	2				平垫圈	PLAIN WASHER	

13020107

消音器总成 SILENCER ASSEMBLY

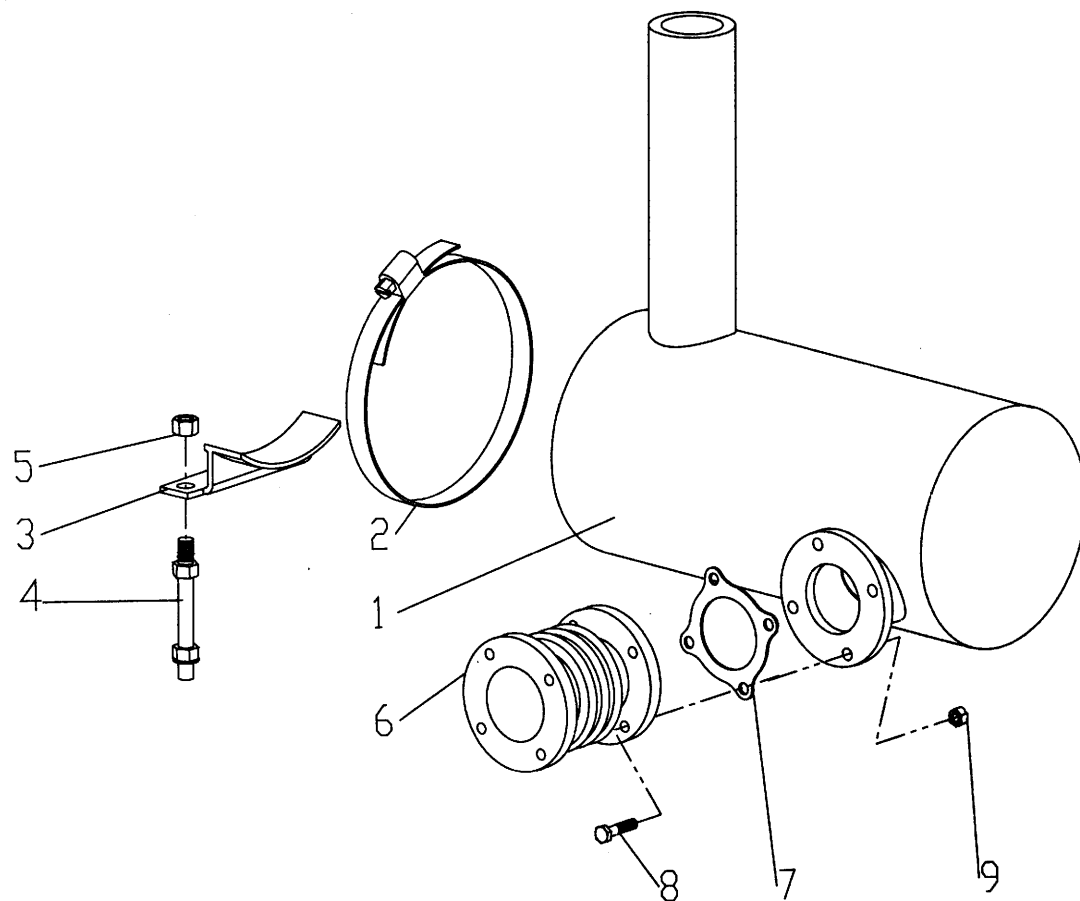

消音器总成 SILENCER ASSEMBLY

序号 Pos.	图号 Teile. Number	组别 Sort	柴油机设计号 (件数) Engine SN Stk.				规格标准 DIN/Fremdfabr. Nr.	中文名称 Denomination	英文名称 Designation
			13020109	13020107	13020106	13020088			
1	13022955	71		1			消音器	SILENCER	
2	13020720	71		1			卡箍	CLIP	
3	13022956	71		1			消音器支架	SILENCER BRACKET	
4	13020714	71		2			连接螺栓	CONNECT BOLT	
5	01112861	71		2		Q360B12	螺母	HEXAGON NUT	
6	13022958	71		1			膨胀节	BULGY JOINT	
7	13021401	71		2			垫片	PLAIN WASHER	
8	01139584	71		4		Q150B0835	六角头螺栓	HEXAGON BOLT	
9	01321455	71		4		Q33208	自锁螺母	HEXAGON NUT	

13020106

消音器总成 SILENCER ASSEMBLY

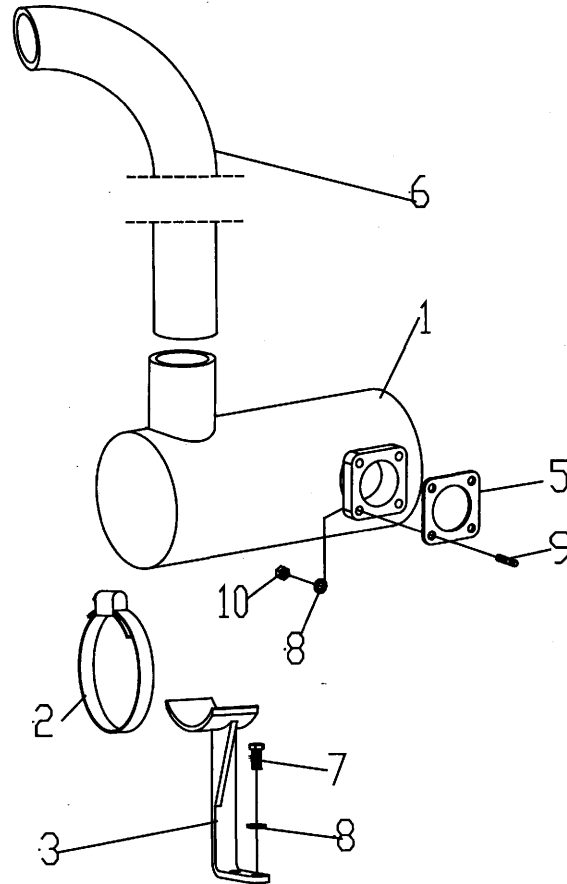

13020088

消音器总成 SILENCER ASSEMBLY

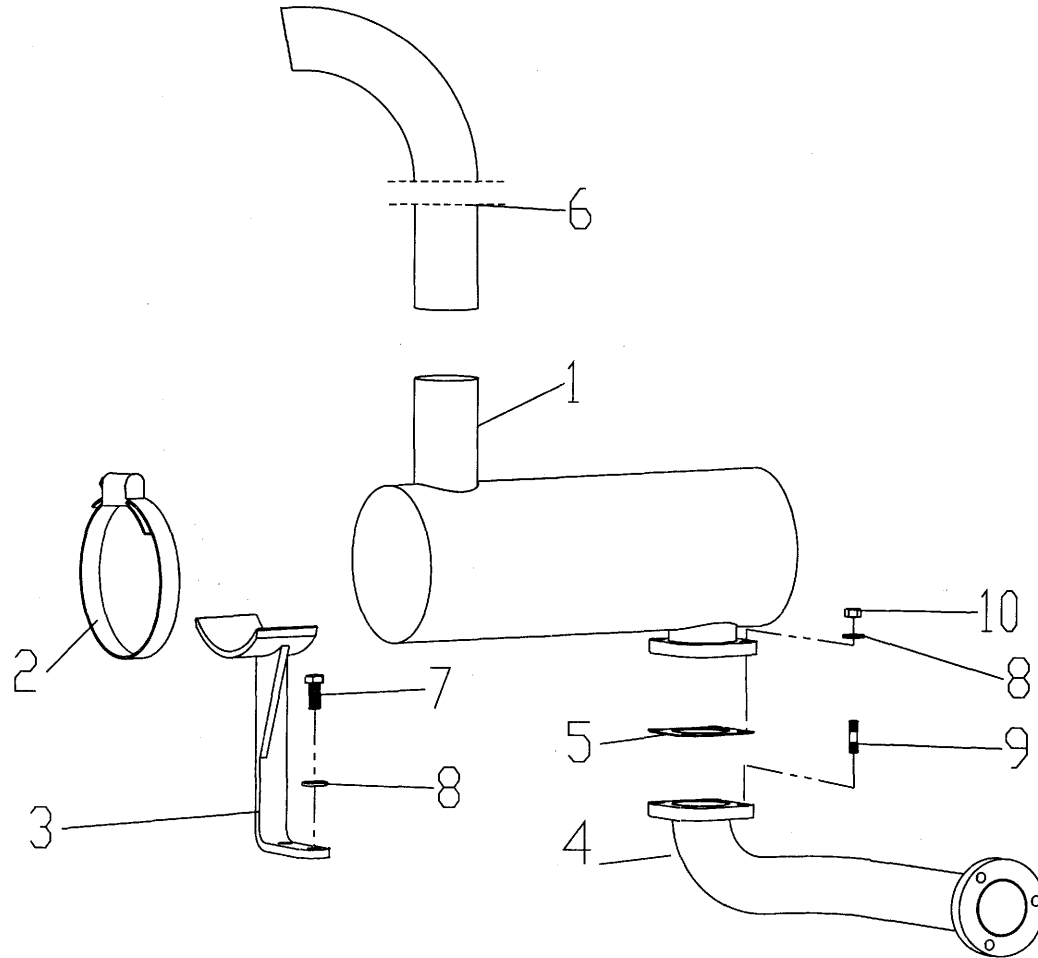

消音器总成 SILENCER ASSEMBLY

序号 Pos.	图号 Teile. Number	组别 Sort	柴油机设计号 (件数) Engine SN Stk.				规格标准 DIN/Fremdfabr. Nr.	中文名称 Denomination	英文名称 Designation
			13020109	13020107	13020106	13020088			
1	13025348	71			1	1		消音器 SILENCER	
1	13022031	71			1	1		消音器 SILENCER	
2	13022307	71			1	1		卡箍带 CLIP	
3	13025353	71			1			支架 SILENCER BRACKET	
3	13022157	71				1		支架 SILENCER BRACKET	
4	13022030	71			1			排气弯管 EXHAUST SYPHON	
4	13022156	71				1		排气弯管 EXHAUST SYPHON	
5	13022028	71			1	1		垫片 PLAIN WASHER	
6	13024518	71			1	1		消音器排气管 EXHAUST PIPE	
6	13022032	71			1	1		消音器排气管 EXHAUST PIPE	
7	01112416	71			2	2	Q150B1025	六角头螺栓 HEXAGON BOLT	
8	01178365	71			6	6	Q40310	弹簧垫圈 SPRING LOCK WASHER	
9	11137472	71			4	4	Q1201030	双头螺柱 DOUBLE - STUD	
10	01143995	71			4	4	Q360B10	六角螺母 HEXAGON NUT	

冷却系统总成 COOLING SYSTEM ASSEMBLY

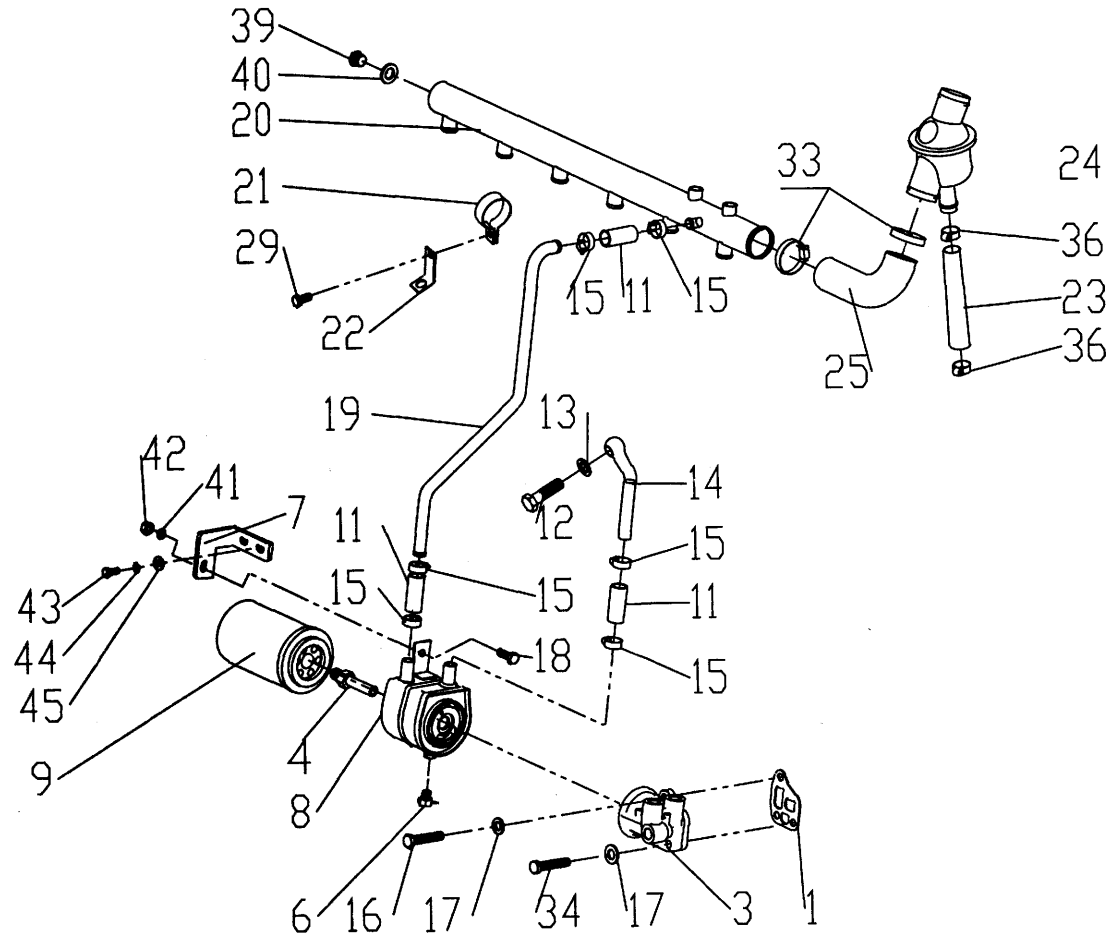

冷却系统总成 COOLING SYSTEM ASSEMBLY

序号 Pos.	图号 Teile. Number	组别 Sort	柴油机设计号 (件数) Engine SN Stk.				规格标准 DIN/Fremdfabr. Nr.	中文名称 Denomination	英文名称 Designation
			13020109	13020107	13020106	13020088			
1	12270878	38	1				密封垫片	SEALING RING	
3	12273107	38	1				机油滤清器滤座	FILTED HEAD	
4	13024129	38	1				连接螺套	CONNECT BREECK BLOCK	
6	13024409	38	1				机油冷却器放水阀	OIL COOLER OFFLET VALVE	
7	13025252	38	1				机油冷却器支架	OIL COOLER BRACKET	
8	13024128	38	1				机油冷却器分总成	OIL COOLER ASSEMBLY	
9	01174421	38	1				旋装式滤清器	SPIN - ON FILTER	
11	01154103	38	3				软管	TUBE	
12	13022197	38	1			D18 - STH3102	空心螺栓	HOLLOW SCREW	
13	01118737	02	2			A22 * 27 - Cu DIN7603	密封垫圈	SEALING RIING	
14	13024225	38	1				冷却水管组件	COOLING WATER ASSENBY	
15	01137412	38	6			Q67527	软管卡箍	TUBE CLIP	
16	01136431	38	1			Q218B1030	内六角圆柱头螺钉	CHEESE HEAD SCREW	
17	01107284	38	3			Q41810	波形弹性垫圈	SPRING WASSHER	
18	01112405	38	1			Q150B1020	六角头螺栓	HEXAGON BOLT	
19	13021635	38	1				回水管	WATER RETURN LINE	
20	13022166	38	1				冷却水管组件	COOLING WATER LINE	
21	12188363	38	1				卡箍	CLIP	
22	12189559	38	1				角板	ANGLE PLATE	
23	13021431	38	1				软管	TUBE	
24	13021133	51	1				节温器	THERMOSTAT	

冷却系统总成 COOLING SYSTEM ASSEMBLY

序号 Pos.	图号 Teile. Number	组别 Sort	柴油机设计号 (件数) Engine SN Stk.				规格标准 DIN/Fremdfabr. Nr.	中文名称 Denomination	英文名称 Designation
			13020109	13020107	13020106	13020088			
25	13021140	38	1				软管	TUBE	
29	01112291	38	1			Q150B0630	六角头螺栓	HEXAGON BOLT	
33	01133878	38	2				软管卡箍	TUBE CLIP	
34	01139277	38	2			Q218B1040	内六角圆柱头螺钉	CHEESE HEAD SCREW	
36	01177986	38	2				软管卡箍	TUBE CLIP	
39	01118960	38	1				六角头螺塞	HEXAGON BOLT	
40	01118693	38	1			A14 * 20 - CuDIN7603	密封垫圈	SEALING RIING	
41	01178365	38	1			Q360B10	弹簧垫圈	SPRING LOCK WASHER	
42	01139401	38	1			Q40310	六角螺母	HEXAGON NUT	
43	01137083	38	2			Q150B0820	六角头螺栓	HEXAGON BOLT	
44	01177981	38	2			Q40308	弹簧垫圈	SPRING LOCK WASHER	
45	01132562	38	2			Q40108	平垫圈	PLAN WASHER	

13020107
13020106
13020088

冷却系统总成 COOLING SYSTEM ASSEMBLY

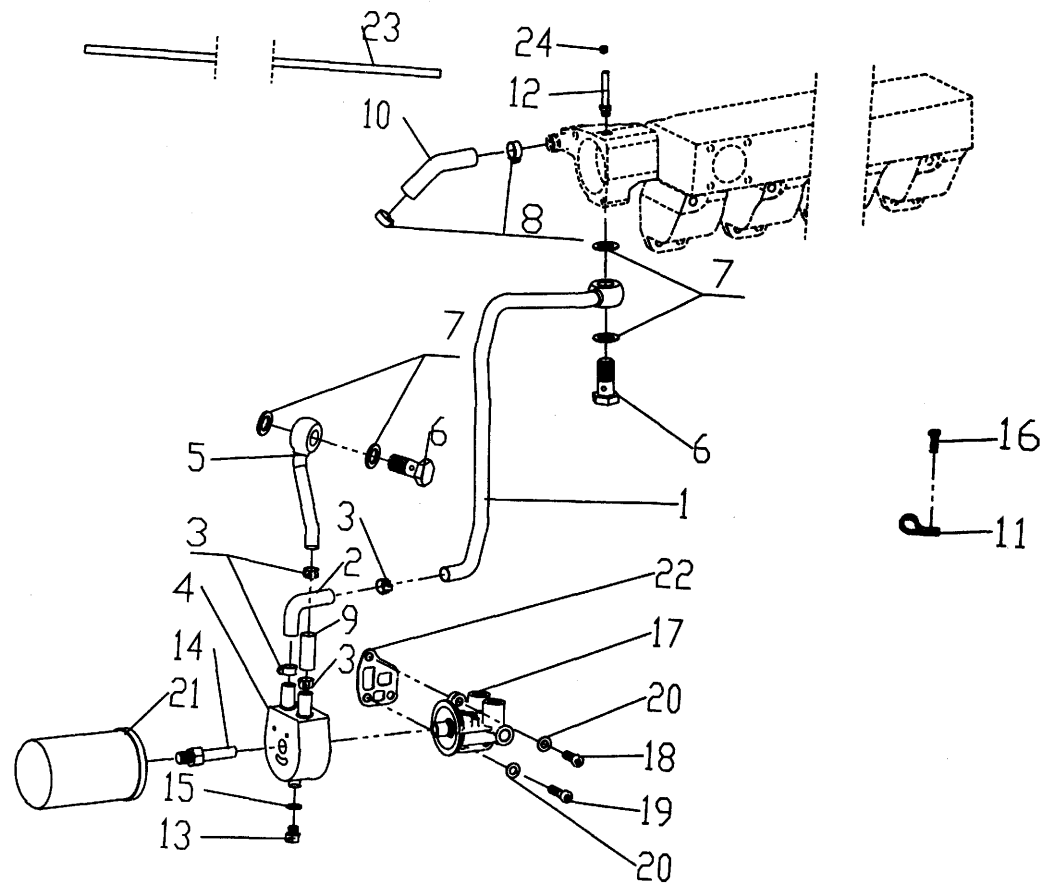

冷却系统总成 COOLING SYSTEM ASSEMBLY

序号 Pos.	图号 Teile. Number	组别 Sort	柴油机设计号 (件数) Engine SN Stk.				规格标准 DIN/Fremdfabr. Nr.	中文名称 Denomination	英文名称 Designation
			13020109	13020107	13020106	13020088			
1	12270761	38		1	1	1		冷却水管分组件	COOLING WATER LINE
2	12188448	38		1	1	1		橡胶弯管	RUBBER SYPHON
3	01137412	38		4	4	4	Q67527	软管卡箍	TUBE CLIP
4	12273290	38		1	1	1		冷却器总成	OIL COOLER
5	13024225	38		1	1	1		冷却水管分组件	COOLING WATER LINE
6	01119254	38		2	2	2	D18M - STH3102	空心螺栓	HOLLOW SCREW
7	13023364	38		4	4	4	22JB982	组合密封垫圈	SEALING RIING
8	01177986	38		2	2	2	Q67545	软管卡箍	TUBE CLIP
9	01154103	38		1	1	1		橡胶软管	RUBBER TUBE
10	13020586	38		1	1	1		橡胶弯管	RUBBER SYPHON
11	12151721	38		1	1	1	RS1100 20/20	软管卡箍	TUBE CLIP
12	13020659	38		1	1	1		管接头	TUBE TIE - IN
13	13021317	22		1	1	1	Q617B22	六角头螺塞	HEXAGON BOLT
14	12273021	15		1	1	1		连接螺套	CONNECTING BOLT BUSH
15	13023358	15		1	1	1	10JB982	组合密封垫圈	SEALING RIING
16	01112331	15		1	1	1	Q150B0825	六角头螺栓	HEXAGON BOLT
17	12273107	15		1	1	1		滤座	OIL CONLER SEAT
18	01136431	15		1	1	1	Q218B1030	内六角圆柱头螺钉	CHEESE HEAD SCREW
19	01139277	15		2	2	2	Q218B1040	内六角圆柱头螺钉	CHEESE HEAD SCREW
20	1501107284	15		3	3	3	Q41810	波形弹性垫圈	SPRING WASSHER
21	12272453	15		1	1	1		旋装式滤清器	SPIN - ON FILTER

冷却系统总成 COOLING SYSTEM ASSEMBLY

序号 Pos.	图号 Teile. Number	组别 Sort	柴油机设计号 (件数) Engine SN Stk.				规格标准 DIN/Fremdfabr. Nr.	中文名称 Denomination	英文名称 Designation
			13020109	13020107	13020106	13020088			
22	12270878	15		1	1	1	密封垫	SEALING RIING	
23	13023186	38		1	1	1	橡胶软管	RVBBER TUBE	
24	13023187	38		1	1	1	钢丝弹簧环箍	SPRING CLIP	

飞轮壳总成 FLYWHEEL HOUSING ASSEMBLY

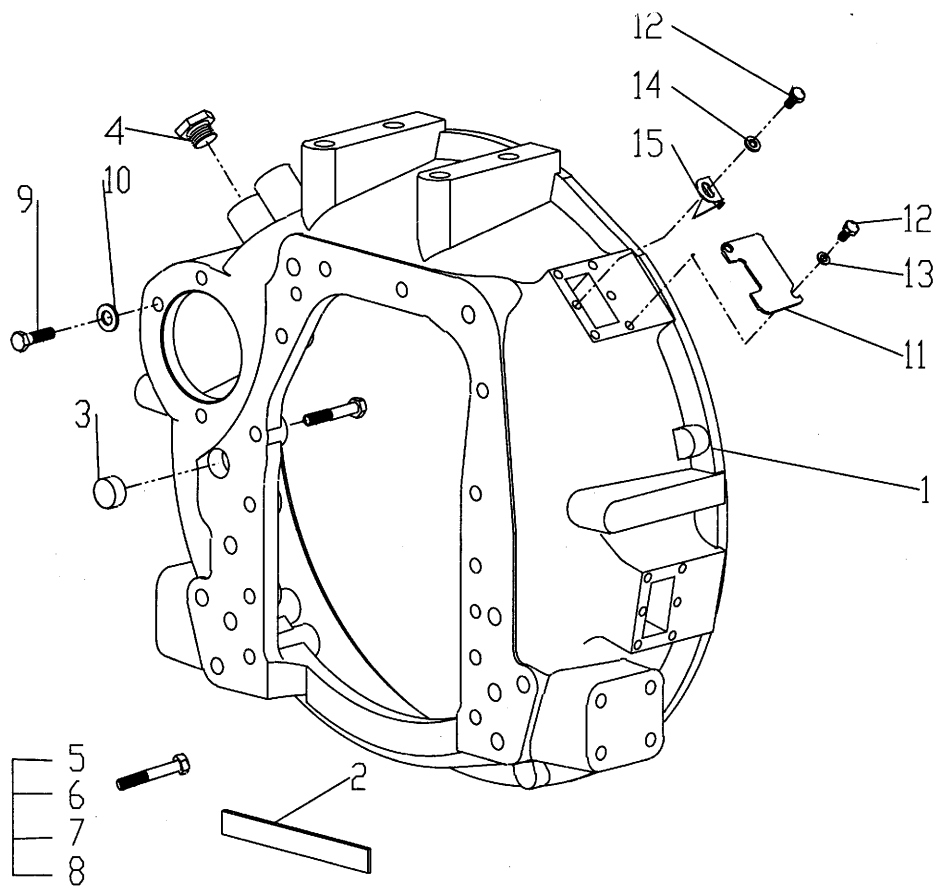

飞轮壳总成 FLYWHEEL HOUSING ASSEMBLY

序号 Pos.	图号 Teile. Number	组别 Sort	柴油机设计号 (件数) Engine SN Stk.				规格标准 DIN/Fremdfabr. Nr.	中文名称 Denomination	英文名称 Designation
			13020109	13020107	13020106	13020088			
1	13023173	52	1					飞轮壳 FLYWHEEL HOUSING	
1	13024241	52		1	1	1		飞轮壳 FLYWHEEL HOUSING	
2	01157512	52	1	1	1	1		密封条 RVBBER STRIP	
3	01097624	52	1	1	1	1		堵塞 PLUG	
4	13022205	52	2	2	2	2	M18 * 1.5	六角头螺塞 HEXAGON BOLT	
5	01139338	52	10	10	10	10	M10 * 35 - 12.9GB5782	六角头螺栓 HEXAGON BOLT	
6	01153777	52	2	2	2	2	M10 * 85 - 12.9GB5782	六角头螺栓 HEXAGON BOLT	
7	01178940	52	2	2	2	2	M12 * 80 - 12.9GB5782	六角头螺栓 HEXAGON BOLT	
8	01112551	52	4	4	4	4	M12 * 45 - 12.9GB5782	六角头螺栓 HEXAGON BOLT	
9	01112427	52	3	3	3	3	Q150B1030	六角头螺栓 HEXAGON BOLT	
10	01178365	52	3	3	3	3	Q40310	弹簧垫圈 SPRING LOCK WASHER	
11	13021291	52	2	1	1	1		检视窗盖 COVER	
12	01112226	52	9	4	4	4	Q150B0608	六角头螺栓 HEXAGON BOLT	
13	01107095	52	4	4	4	4		平垫圈 PLAIN WASHER	
14	01178307	52	5	4	4	4	Q40306	弹簧垫圈 SPRING LOCK WASHER	
15	13021292	52	1					指针 FINGER	

三角带总成 NARRON V - BELT ASSEMBLY

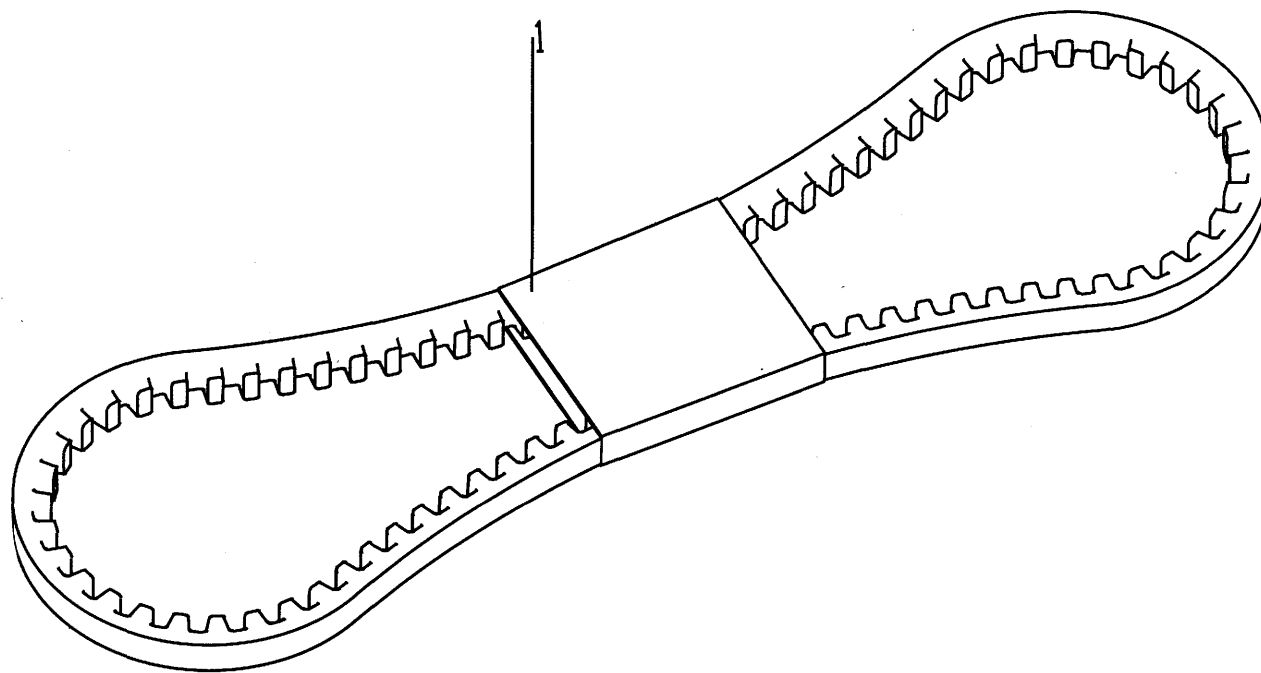

三角带总成 NARRON V - BELT ASSEMBLY

序号 Pos.	图号 Teile. Number	组别 Sort	柴油机设计号 (件数) Engine SN Stk.				规格标准 DIN/Fremdfabr. Nr.	中文名称 Denomination	英文名称 Designation
			13020109	13020107	13020106	13020088			
1	02234343	37	2				窄三角皮带 窄三角皮带	NARRON V - BELT	
1	13020641	37		1	1	1		NARRON V - BELT	

启动机总成 STARTER ASSEMBLY

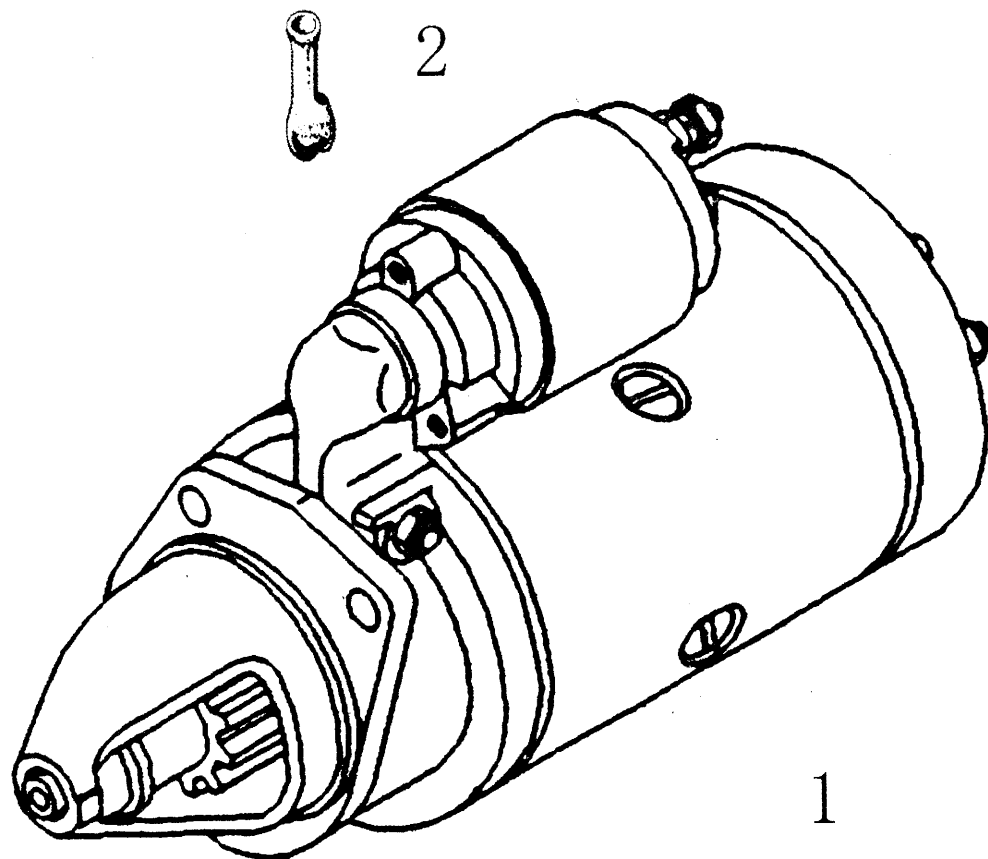

启动机总成 STARTER ASSEMBLY

序号 Pos.	图号 Teile. Number	组别 Sort	柴油机设计号 (件数) Engine SN Stk.				规格标准 DIN/Fremdfabr. Nr.	中文名称 Denomination	英文名称 Designation
			13020109	13020107	13020106	13020088			
1	12153838	44	1	1	1	1	起动机 护帽	STARTER PROTECTING CAP	
2	01169029	44	1	1	1	1			

13020109

发电机及支架总成 ALTERNATOR AND BRACKET ASSEMBLY

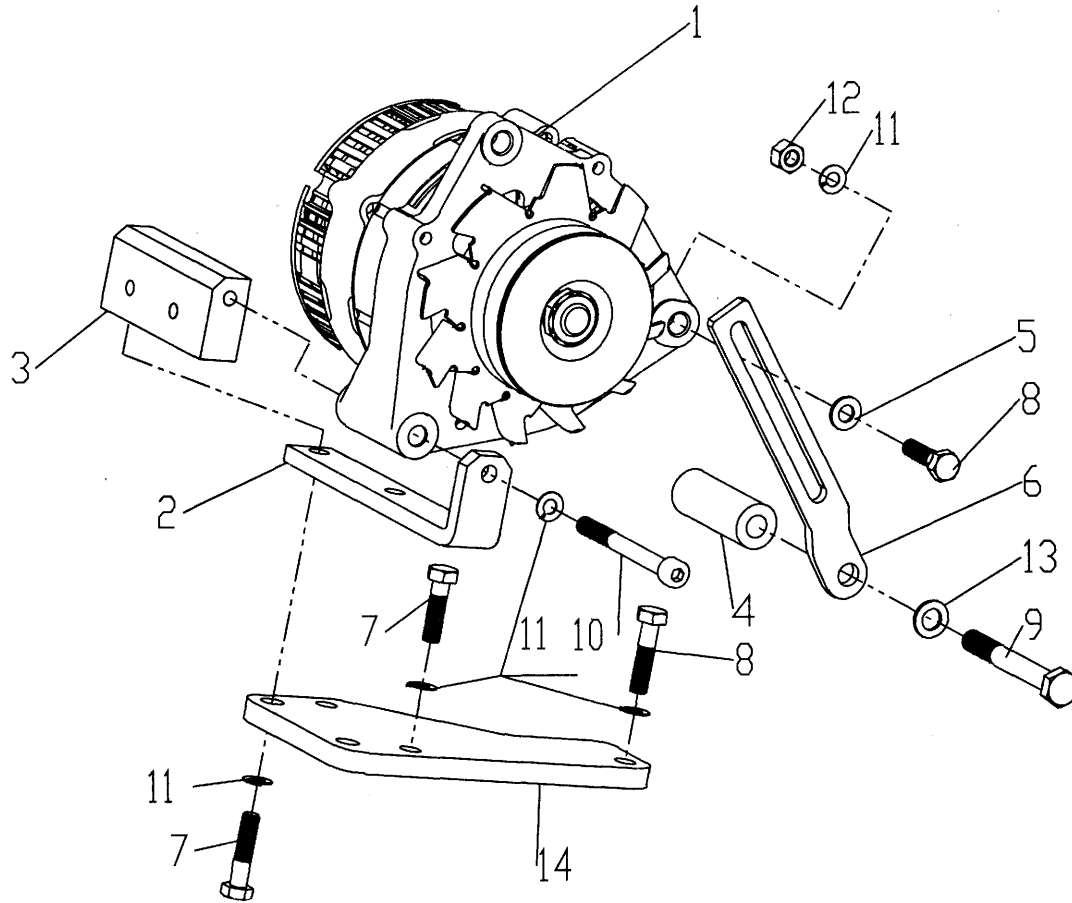

发电机及支架总成 ALTERNATOR AND BRACKET ASSEMBLY

序号 Pos.	图号 Teile. Number	组别 Sort	柴油机设计号 (件数) Engine SN Stk.				规格标准 DIN/Fremdfabr. Nr.	中文名称 Denomination	英文名称 Designation
			13020109	13020107	13020106	13020088			
1	12903819	44	1				K1 - 28V27A	发电机	ALTERNATOR
2	12200613	44	1					发电机支架	BRACKET
3	12200614	44	1					发电机支架	BRACKET
4	12200615	44	1					套筒	BUSH
5	12165765	44	1					垫片	PLAIN WASHER
6	13020949	44	1					搭板	CONNECTING PLATE
7	01139584	44	4				Q150B0835	六角头螺栓	HEXAGON BOLT
8	01112339	44	2				Q150B0830	六角头螺栓	HEXAGON BOLT
9	01113397	44	1				Q150B1080	六角头螺栓	HEXAGON BOLT
10	01110618	44	1				M8 * 80 - 12.9GB70	内六角圆柱头螺钉	CHEESE HEAD SCREW
11	01177981	44	7				Q40308	弹簧垫圈	SPRING WASHER
12	01112829	44	4				Q360B08	六角螺母	HEXAGON NUT
13	01152752	44	1				Q40110	平垫圈	PLAIN WASHER
14	13021432	44	1					发电机支架	BRACKET

13020107
13020106
13020088

发电机及支架组件 ALTERNATOR AND BRACKET ASSEMBLY

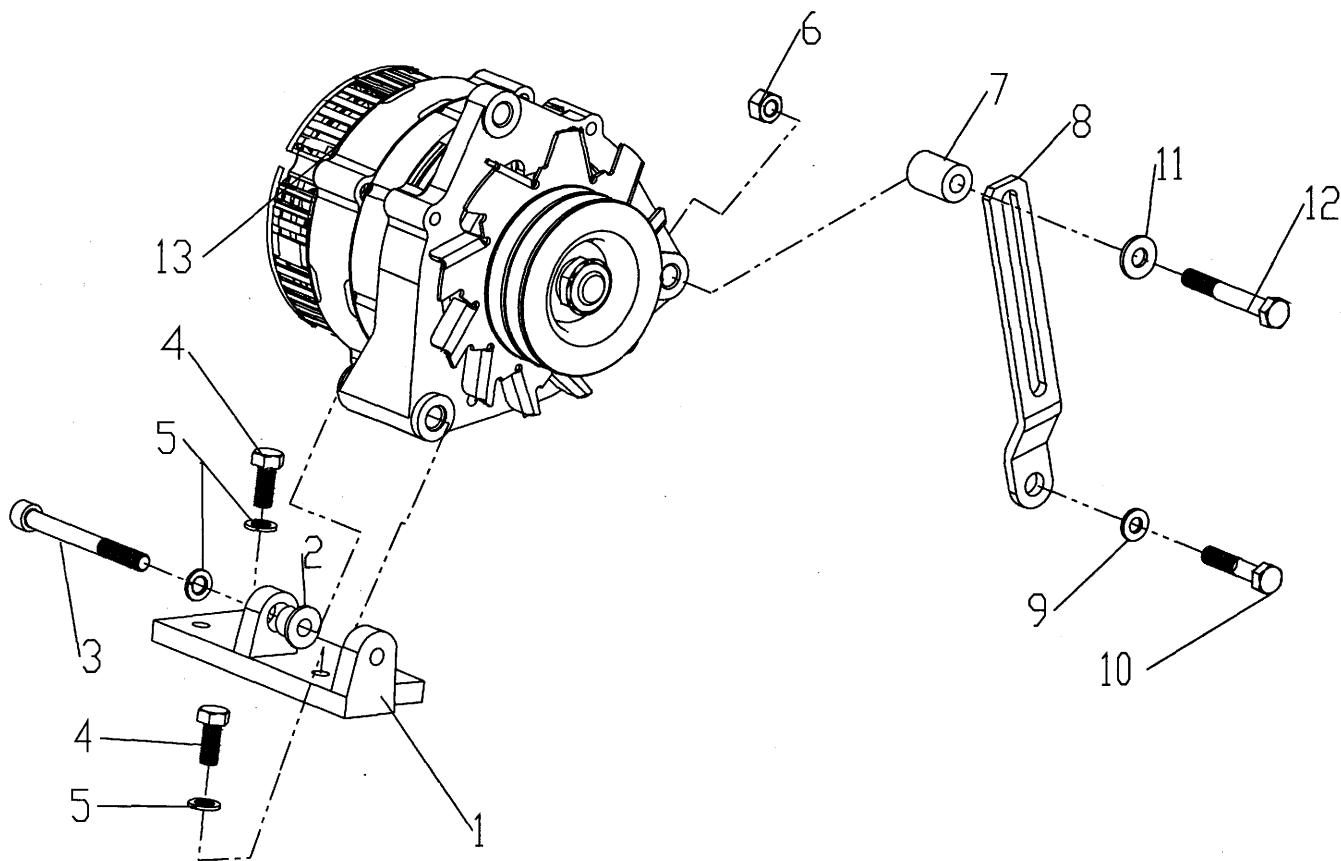

发电机及支架组件 ALTERNATOR AND BRACKET ASSEMBLY

序号 Pos.	图号 Teile. Number	组别 Sort	柴油机设计号 (件数) Engine SN Stk.				规格标准 DIN/Fremdfabr. Nr.	中文名称 Denomination	英文名称 Designation
			13020109	13020107	13020106	13020088			
1	12270276	44		1	1	1		发电机支架	BRACKET
2	12190551	44		1	1	1		套筒	BUSH
3	01110618	44		1	1	1	M8 * 80 - 10.9GB70	内六角圆柱头螺钉	CHEESE HEAD SCREW
4	01139584	44		2	2	2	Q150B0835	六角头螺栓	HEXAGON BOLT
5	01177981	44		3	3	3	Q40308	弹簧垫圈	SPRING WASHER
6	01112829	44		3	3	3	Q360B08	六角螺母	HEXAGON NUT
7	13021990	44		1	1	1		搭板支架	BRACKET
8	13020949	44		1	1	1		搭板	CONNECTING PLATE
9	01152752	44		1	1	1	Q40110	平垫圈	PLAIN WASHER
10	01112405	44		1	1	1	Q150B1020	六角头螺栓	HEXAGON BOLT
11	01155765	44		1	1	1		垫片	PLAIN WASHER
12	00111166	44		1	1	1	Q150B0860	六角头螺栓	HEXAGON BOLT
13	13020748	44		1	1	1		发电机组件	ALTERNATOR

发动机支架总成 ENGINE BRACKET ASSEMBLY

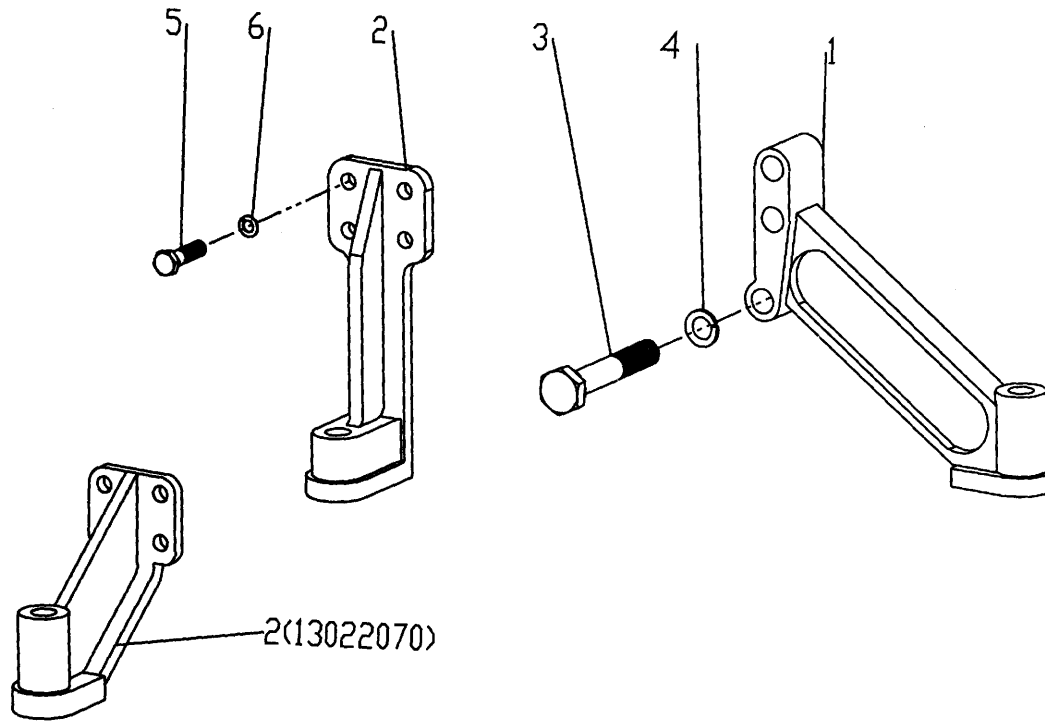

发动机支架总成 ENGINE BRACKET ASSEMBLY

序号 Pos.	图号 Teile. Number	组别 Sort	柴油机设计号 (件数) Engine SN Stk.				规格标准 DIN/Fremdfabr. Nr.	中文名称 Denomination	英文名称 Designation
			13020109	13020107	13020106	13020088			
1	13021906	46	2	2	2	2		发动机前支架	FRONT BRACKET
2	13021907	46	2					发动机后支架	BACK BRACKET
2	13022070	46		2	2	2		发动机后支架	BACK BRACKET
3	13022652	46	6	6	6	6	Q150B1855	六角头螺栓	HEXAGON BOLT
4	12151281	46	6	6	6	6	Q40318	弹簧垫圈	SPRING WASHER
5	01151548	46	8	8	8	8	Q150B1230	六角头螺栓	HEXAGON BOLT
6	01178366	46	8	8	8	8	Q40312	弹簧垫圈	SPRING WASHER

13020109

水箱总成 RADIATOR ASSEMBLY

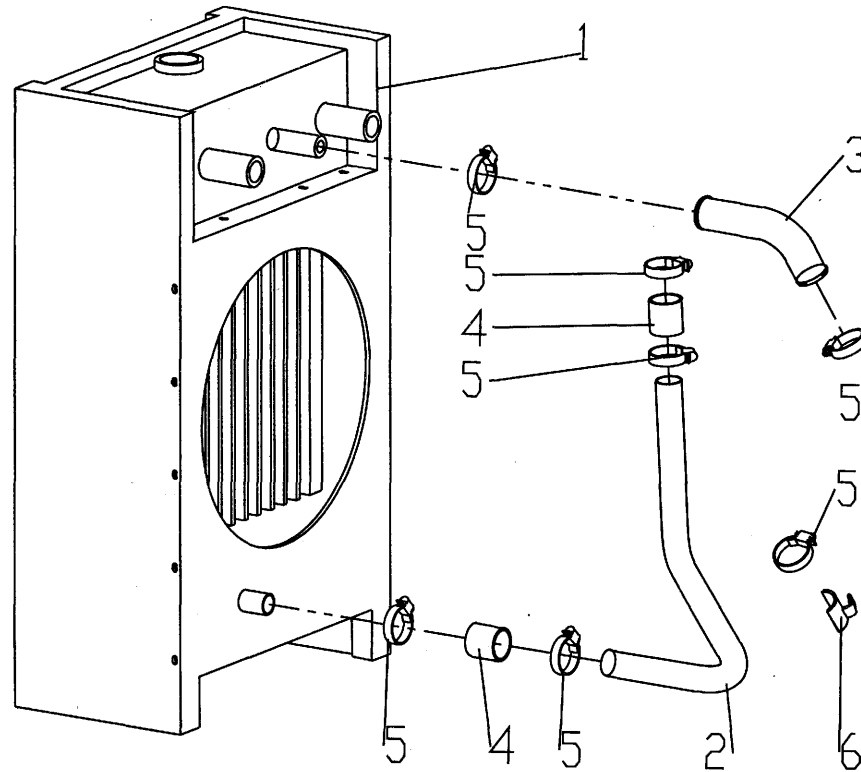

13020107
13020106
13020088

水箱总成 RADIATOR ASSEMBLY

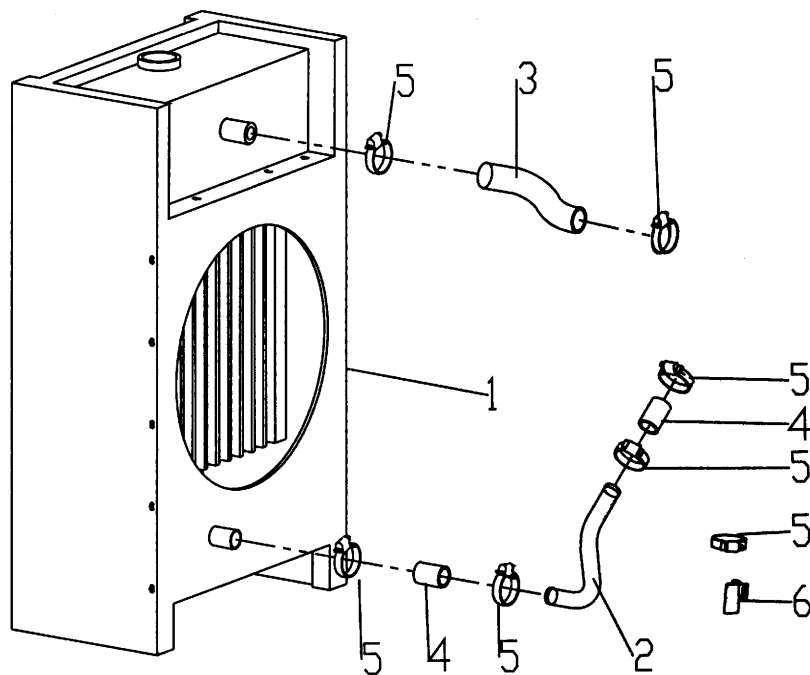

水箱总成 RADIATOR ASSEMBLY

序号 Pos.	图号 Teile. Number	组别 Sort	柴油机设计号 (件数) Engine SN Stk.				规格标准 DIN/Fremdfabr. Nr.	中文名称 Denomination	英文名称 Designation
			13020109	13020107	13020106	13020088			
1	13021901	90	1				水箱	RADIATOR	
1	13021988	90		1	1	1	水箱	RADIATOR	
2	13021887	90	1				水泵进水管	INLET PIPE	
2	13021981	90		1	1	1	水泵进水管	INLET PIPE	
3	13021272	90	1				水箱出水管	OUTLET PIPE	
3	13021980	90		1	1	1	水箱出水管	OUTLET PIPE	
4	13022206	90	2				橡胶管	RUBBER PIPE	
4	13022596	90		2	2	2	橡胶管	RUBBER PIPE	
5	01133878	90	7	7	7	7	软管卡箍	CLIP	
6	13022055	90	1	1	1	1	水管支架	BRACKET	

燃油回油管总成 LEAK OFF LINE ASSEMBLY

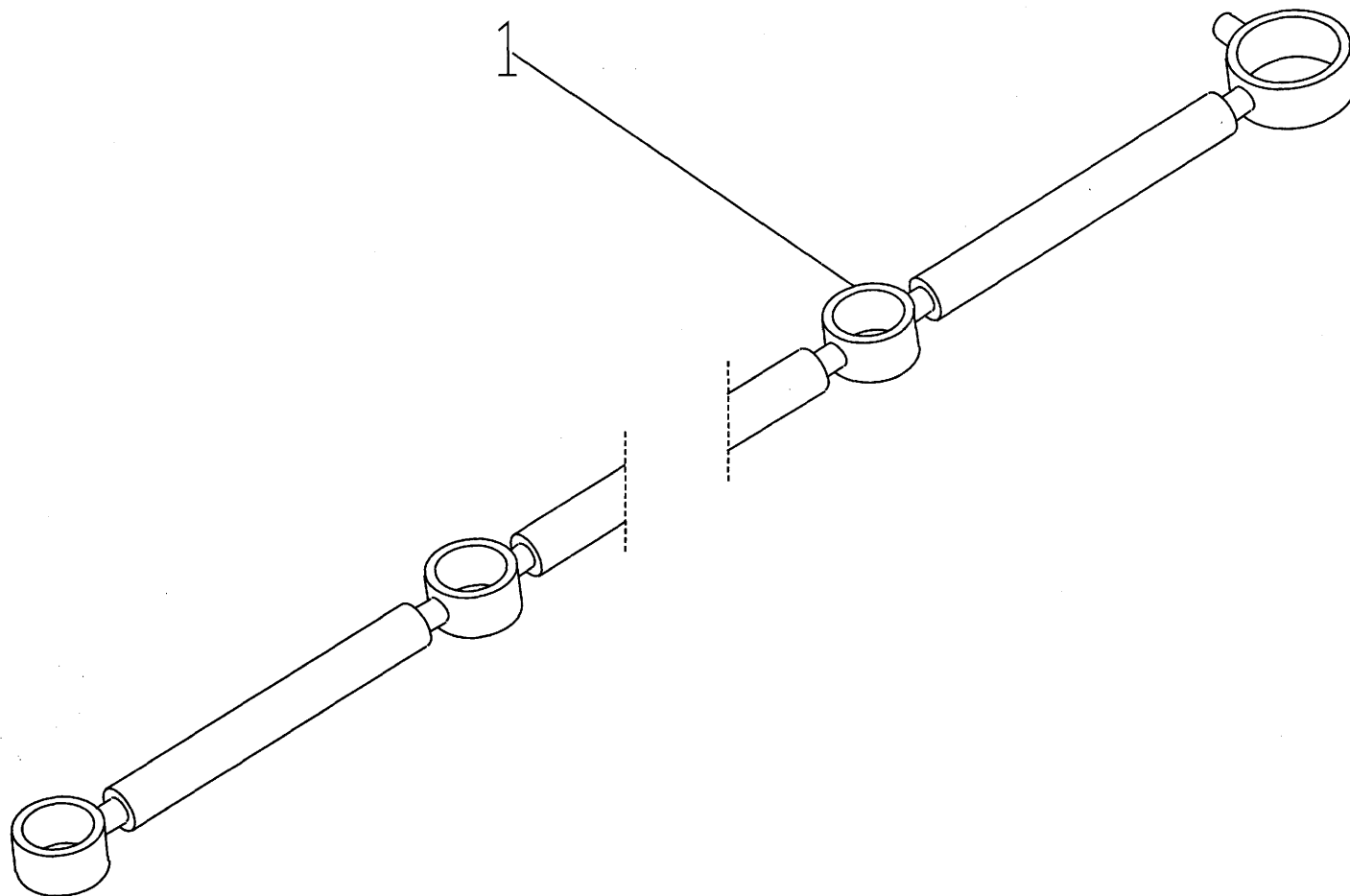

燃油回油管总成 LEAK OFF LINE ASSEMBLY

序号 Pos.	图号 Teile. Number	组别 Sort	柴油机设计号 (件数) Eng'ie SN Stk.				规格标准 DIN/Fremdfabr. Nr.	中文名称 Denomination	英文名称 Designation
			13020109	13020107	13020106	13020088			
1	13020490	21	1				燃油回油管 燃油回油管 燃油回油管	LEAK OFF LINE	
1	12272063	21		1				LEAK OFF LINE	
1	12270968	21			1	1		LEAK OFF LINE	

防护罩总成 SHEILD ASSEMBLY

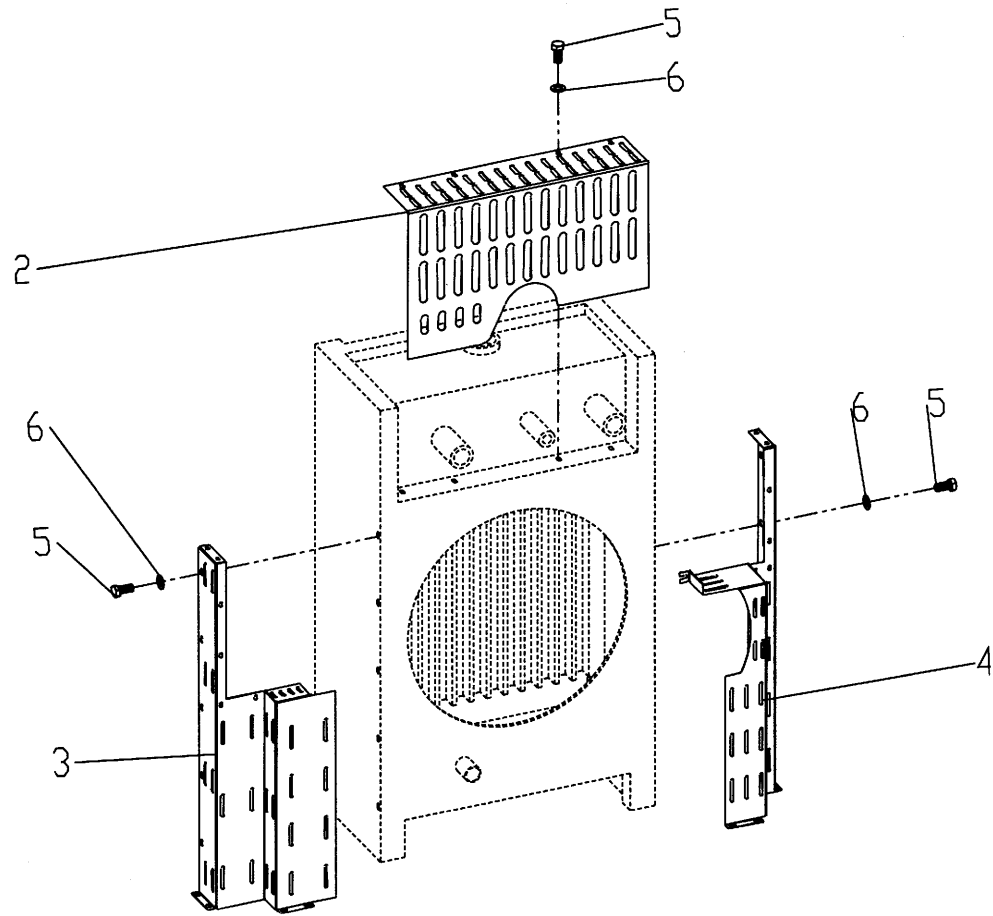

防护罩总成 * SHEILD ASSEMBLY

序号 Pos.	图号 Teile. Number	组别 Sort	柴油机设计号 (件数) Engine SN Stk.				规格标准 DIN/Fremdfabr. Nr.	中文名称 Denomination	英文名称 Designation
			13020109	13020107	13020106	13020088			
2	13025143	90	1				后挡板	BACK BAFFLE	
3	13025142	90	1				左挡板	LEFT BAFFLE	
3	13025144	90		1	1	1	左挡板	LEFT BAFFLE	
4	13025141	90	1				右挡板	RIGHT BAFFLE	
4	13025145	90		1	1	1	右挡板	RIGHT BAFFLE	
5	01151569	90	30	26	26	26	六角头螺栓	HEXAGON BOLT	
6	01177981	90	30	26	26	26	弹簧垫圈	SPRING WASHER	

* 为 CE 认证 226B 柴油机用

