

道依茨226B系列
发电用柴油机使用保养说明书
Operation and Maintenance Manual of
Deutz 226B Series Generating Diesel Engine



潍坊潍柴道依茨柴油机有限公司
Weifang Weichai Deutz Diesel Engine Company Ltd



Special attention

- In order to protect your legal interest, it is forbidden to dismantle the fuel pump lead seal optionally
- If the injection pump were adjusted or lead seal were removed, the quality guarantee of the company would become invalid immediately.
- We would not provide free service for the dismantled injection pump.
- Turbocharger rotor shaft is of precise part, forbid disassembling and colliding, Otherwise the quality guarantees of the company will be of invalid.
- There are strict torques and turn angles for the main bearing bolts and connecting rod bolts, Users don't loose and dismantle them, otherwise the quality guarantees of the company will be of invalid.
- Before starting the engine, check coolant and oil whether they are filled up or not.
- Connecting rod bolt can't be reused.
- Meaning of identification:
- Exhaust gas contains noxious composition, therefore it must be discharged outdoors.

Cautions

1. The engine has been tested strictly in accordance with the test stipulations in delivery. The throttle has been sealed, it is forbidden to dismantle the seal optionally and to enlarge the throttle. Otherwise we would not provide free service for returning product, replacement and repair, users would better pay attention to this.
2. The engine operator must read this Operation and Maintenance Manual carefully to know the engine's structure, and abide by the operation and routine rules in this manual.
3. During use new engine, a 50 hours run-in must be carried through, during which period no overload operation is allowed.
4. After start cold engine, the speed should be increased slowly. It is forbidden to run the engine in high speed suddenly and in idling for a long time. After removed the load, don't stop the engine immediately and run the engine in idling for 5 – 10 minutes.
5. After stop the engine, if the ambient temperature is lower than 0°C and no antifreeze is used in the coolant, the coolant in water tank and diesel engine should be drained off.
6. It is forbidden that the engine works without air filter and unfiltered air enters into the cylinder.
7. Applied fuel and lubricating oil must be accord with specified trademark and be filtered by strainer, and the special clean container is used. The fuel should be settled more than 72 hours.
8. Assembly and maintenance of the engine must be done by specialized personnel.
9. The oil seal period of the engine is one year. Inspect the engine and adopt necessary measures if beyond a year.
10. Rated power and power correction are in accordance with ISO3046 – 1.
11. It's forbidden to smoke when filling fuel and /or oil.

Contents

Preface	1
Diesel engine photo	2
Diesel engine characteristic curve	4
1 Main performance and specifications	7
2 Specifications of main accessories	8
Fuel system matching table	10
3. Diesel engine construction	11
3.1 Cross and longitudinal section view of diesel engine	11
3.2 Cylinder block subassembly	13
3.3 Crank shaft and connecting rod mechanism	16
3.4 Gear train	19
3.5 Cylinder head and valve system	19
3.6 Fuel supply system	22
3.7 Lubricating system	26
3.8 Cooling system	27
3.9 Intake & exhaust system	29
3.10 Electrical system	31
3.11 Main bolts tightening torque	34
4. Operating requirement and procedures	36
4.1 Rules on the working fluid and the auxiliary material	36
4.2 swinging requirement	39
4.3 Preparation before the start	39
4.4 Start	41
4.5 Speed regulating	42
4.6 stopping the engine	42
4.7 Operating environment	43
5. Maintenance	44
5.1 Time table for Maintenance	44
5.2 Maintenance procedure	45
6. Trouble shooting	50
Appendix 1 : Relationship between crankshaft angle Φ and piston displacement S	51
Appendix 2 : Wear Limits of Parts of the Engine	52

Preface

226B series diesel engine is manufactured by Weifang Weichai Deutz Diesel Engine Company Ltd (composed of Weifang Diesel Engine Works and Germany Deutz Company).

According to intake mode, 226B series diesel engine is divided into natural aspirating, turbo-charging, turbo-charging and inter-cooling type. With 3, 4 and 6 cylinders, it is a high-speed, 4-stroke, water-cooled, in-line and direct-injection engine. It has advantages of reliable and economical in working, advanced technical data, low emission, good low-temperature start, simple operation and convenient maintenance. The speed range is 1500r/min - 1800r/min and power range is 30 - 135kW. The symbols in each type of engine represent the following meanings:

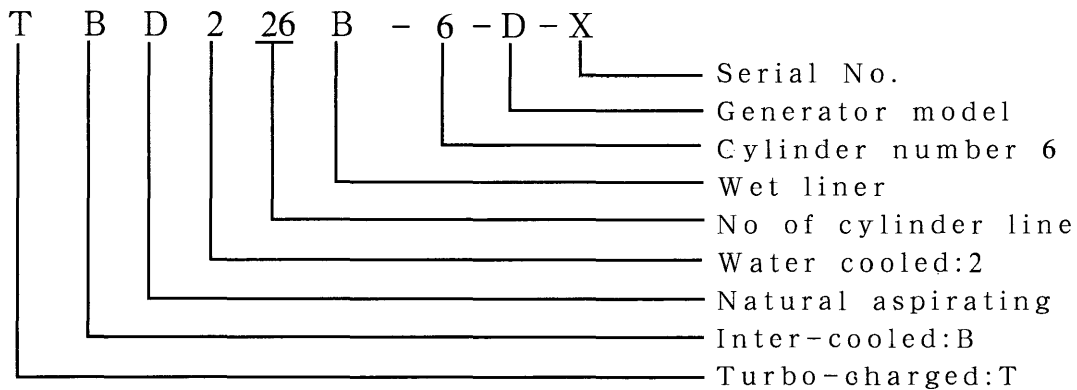

Nameplate is fitted on the engine in delivery, model, design number, power, speed, serial number, manufacturer, address, manufacturing date and weight are marked on the nameplate. Each design number corresponds to certain engine, each model may have several design numbers. The serial number is marked on the cylinder block and located under the oil filter seat.

This manual introduces the main technical data, construction features, operation and maintenance methods and inspection points of 226B series diesel engine. It applies to all the generator engine models for the customers.

In order to make 226B series diesel engine provide better service for you, it's better for users to know the basic to refer to structures and the engine operating methods so as to play its active role.

With the development of the production technology, the construction, accessories and performance parameters of 226B engine will be improved gradually. The product in the manual may be slightly different from the supplied one, pay attention to the supplementary manual. It is subjected to change without notice.

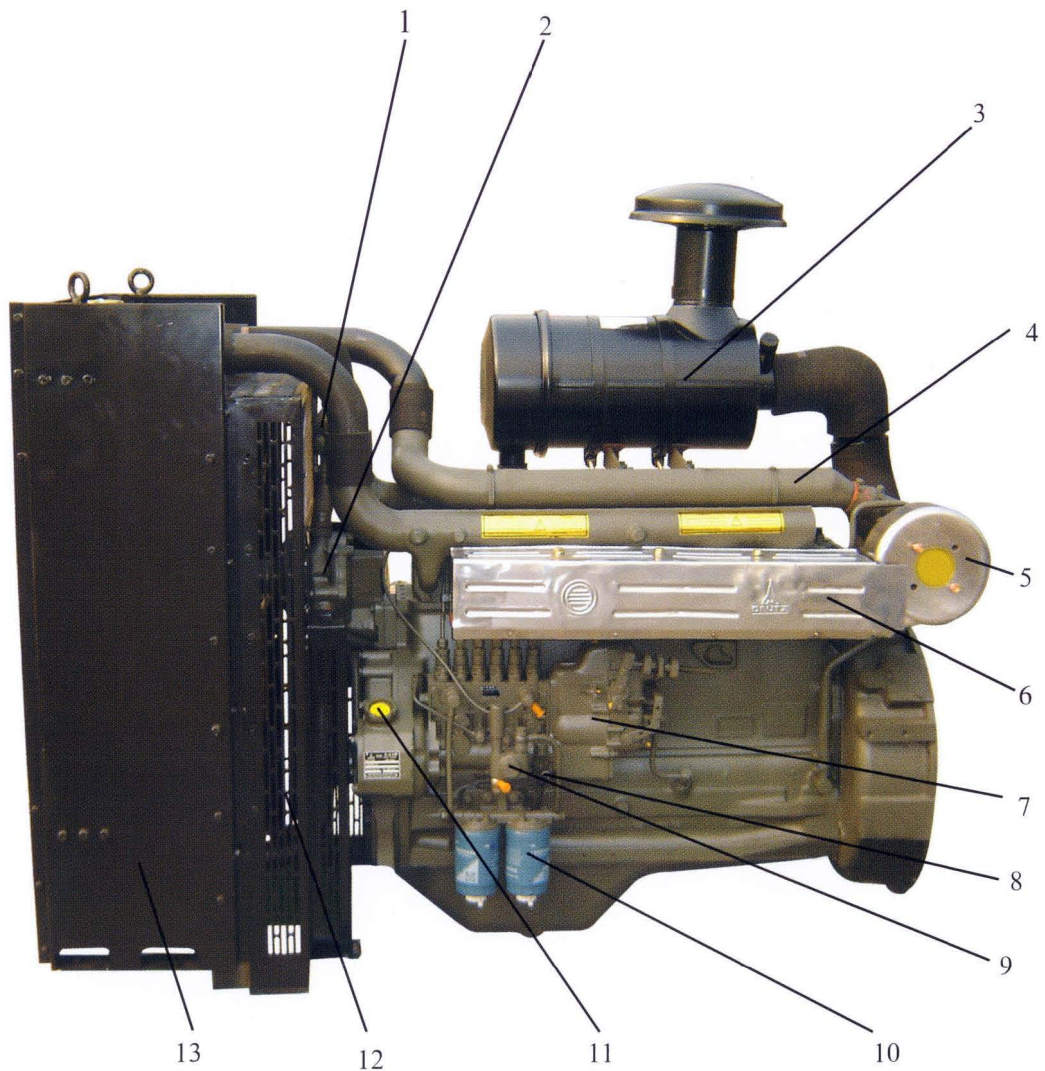

6-cylinder diesel engine

- 1 Thermostat 2 Water pump 3 Air clearer 4 Intake manifold(only for intercooled engine)
- 5 Heat shield for turbocharger 6 Exhaust pipe frock 7 Inection pump and governor
- 8 Oil dipstick 9 Fuel supply pump 10 Fuel filter 11 Oil filler 12 guard shield
- 13 Warer tank

Remark:The counter parts of number 5、6、12 are not equipped on general gen-engine,However, they are compositions of CE-certificated models.

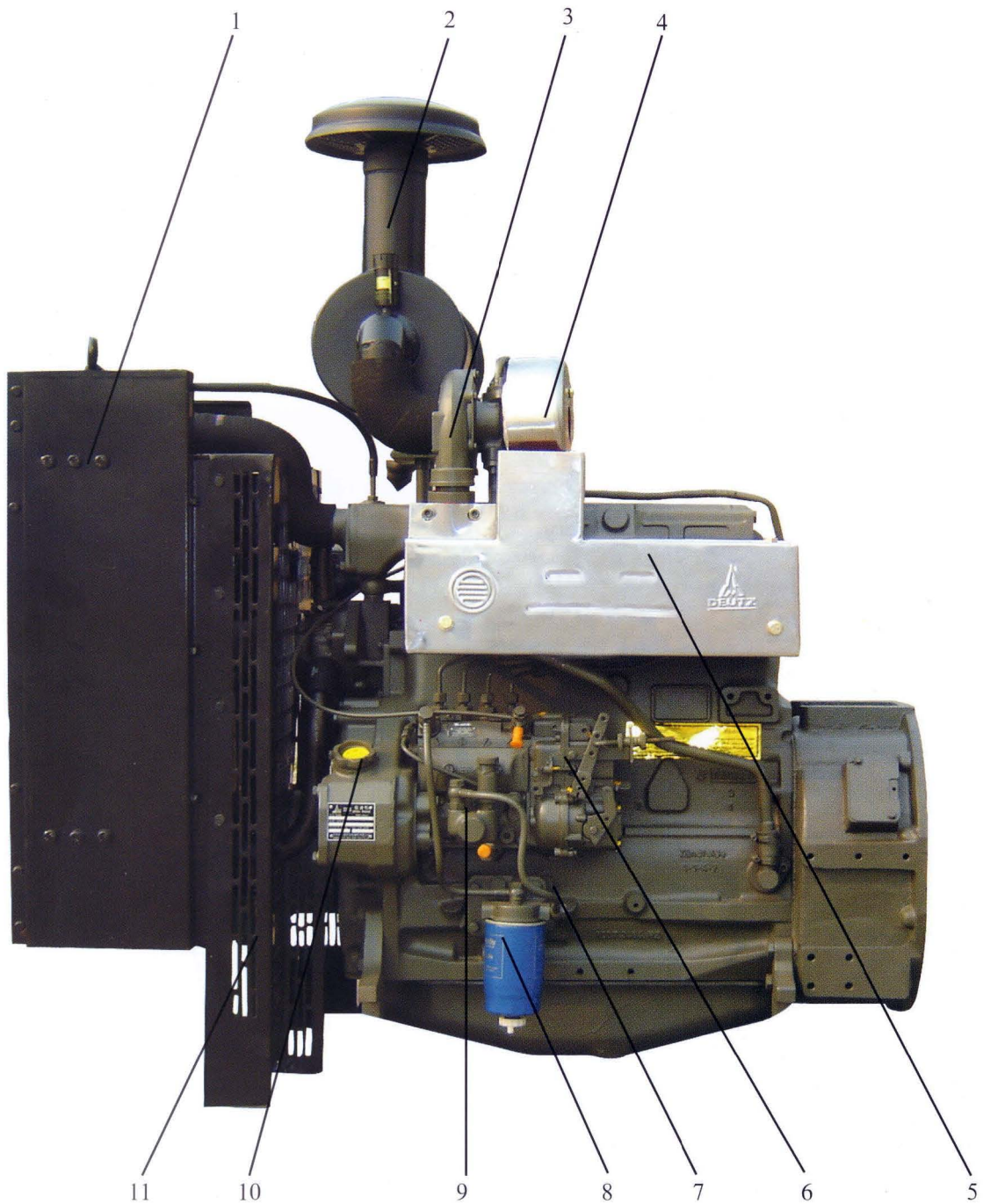

4-cylinder diesel engine

- 1 Water tank 2 Air clearer 3 Turbocharger 4 Heat shield for turbocharger
 5 Exhaust pipe frock(Only for turbocharged engine) 6 Inection pump and governor
 7 Oil dipstick 8 Fuel filter 9 Fuel supply pump 10 Oil filler 11 guard shield

Remark:The counter parts of number 4、5、11 are not equipped on general gen-engine,However, they are compositiions of CE-certificated models.

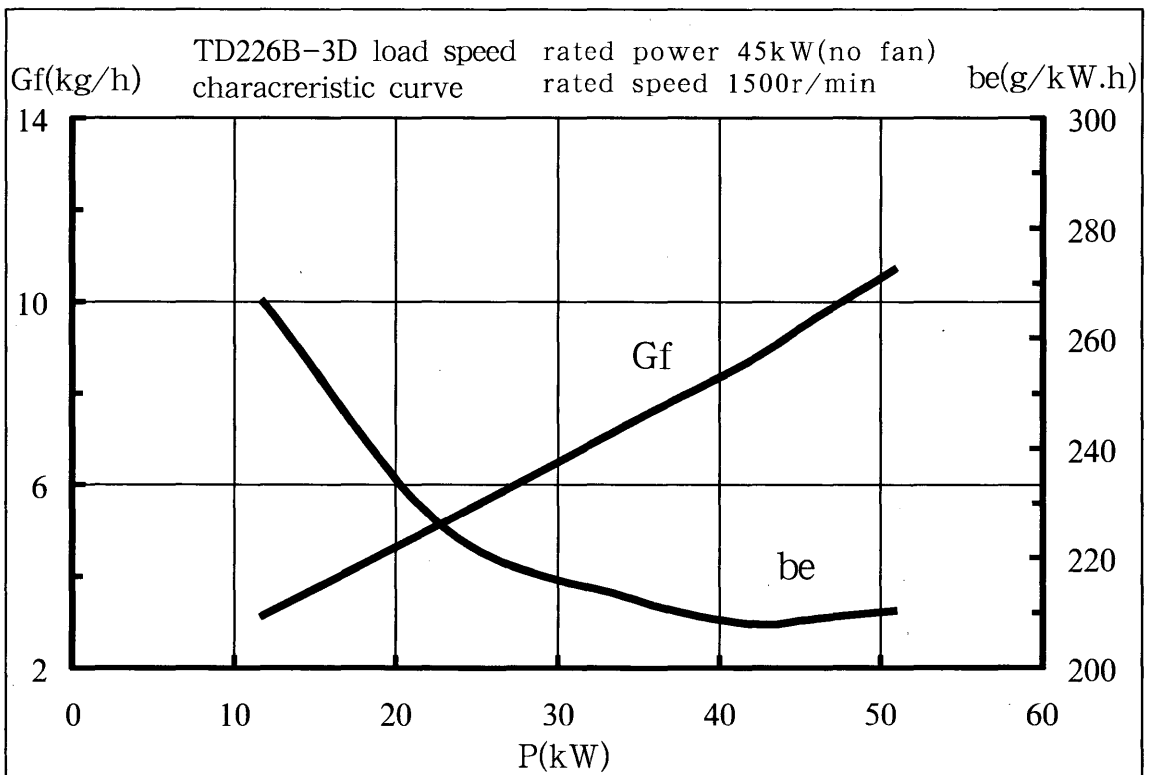
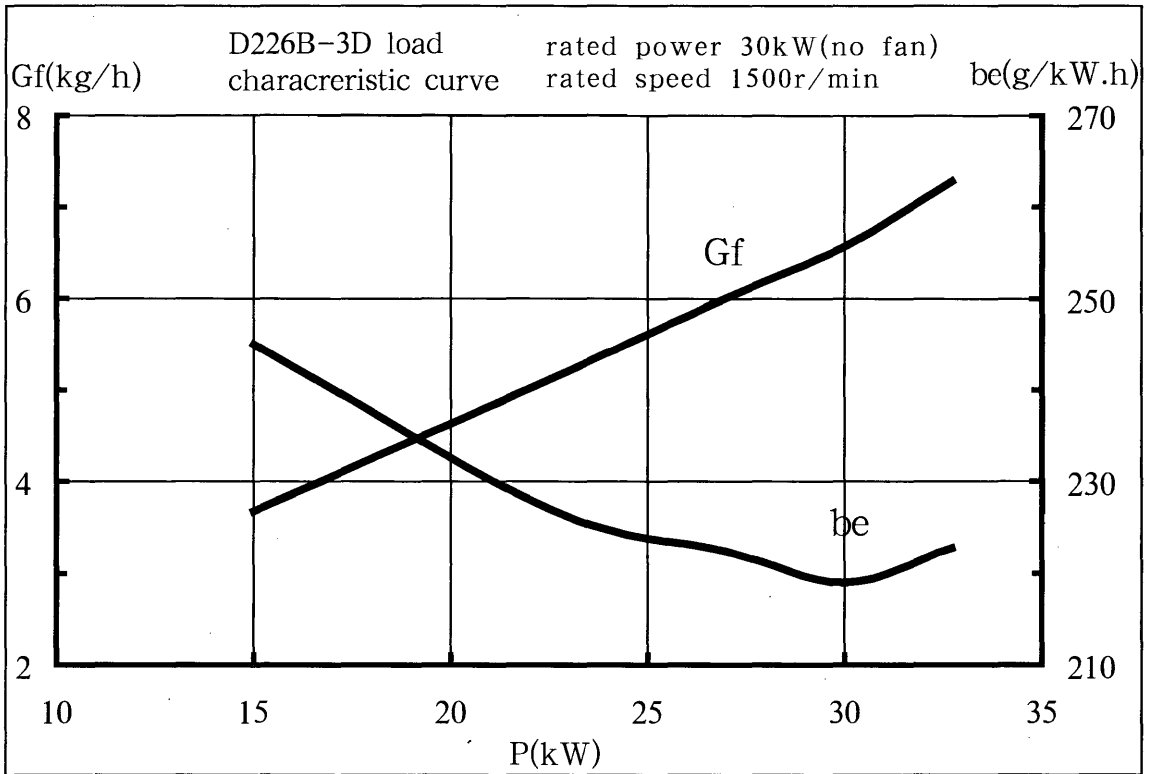

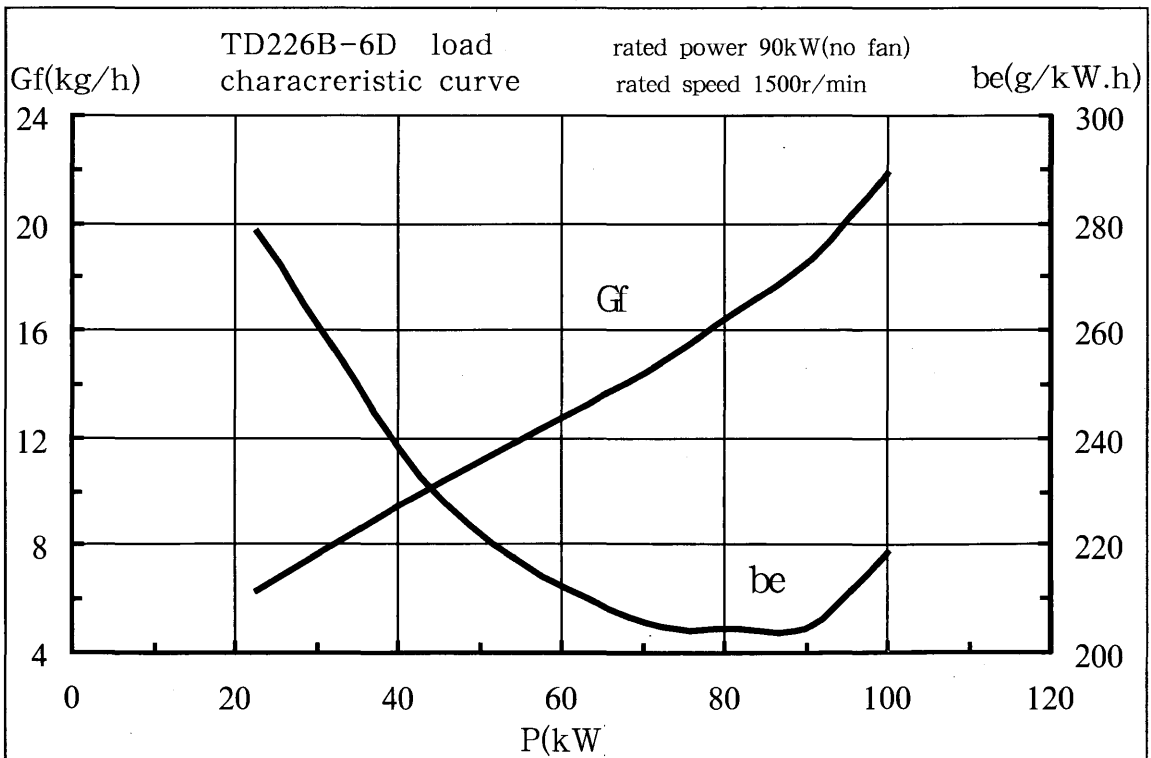
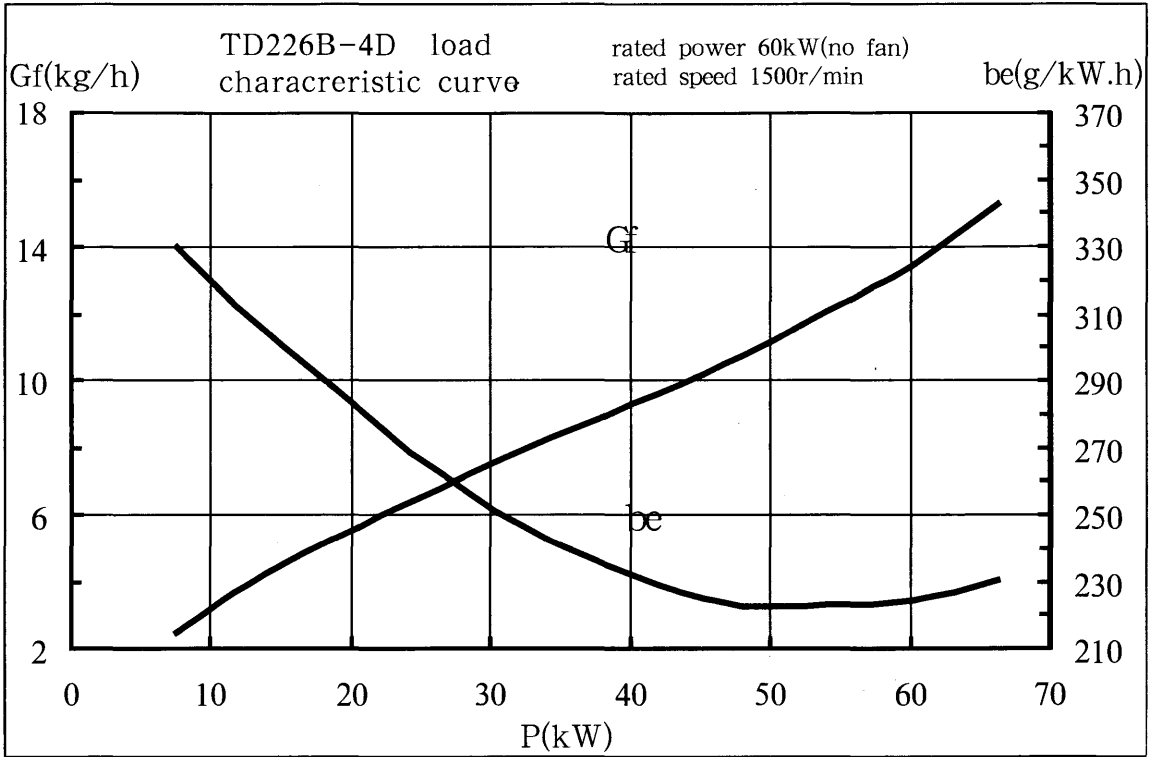

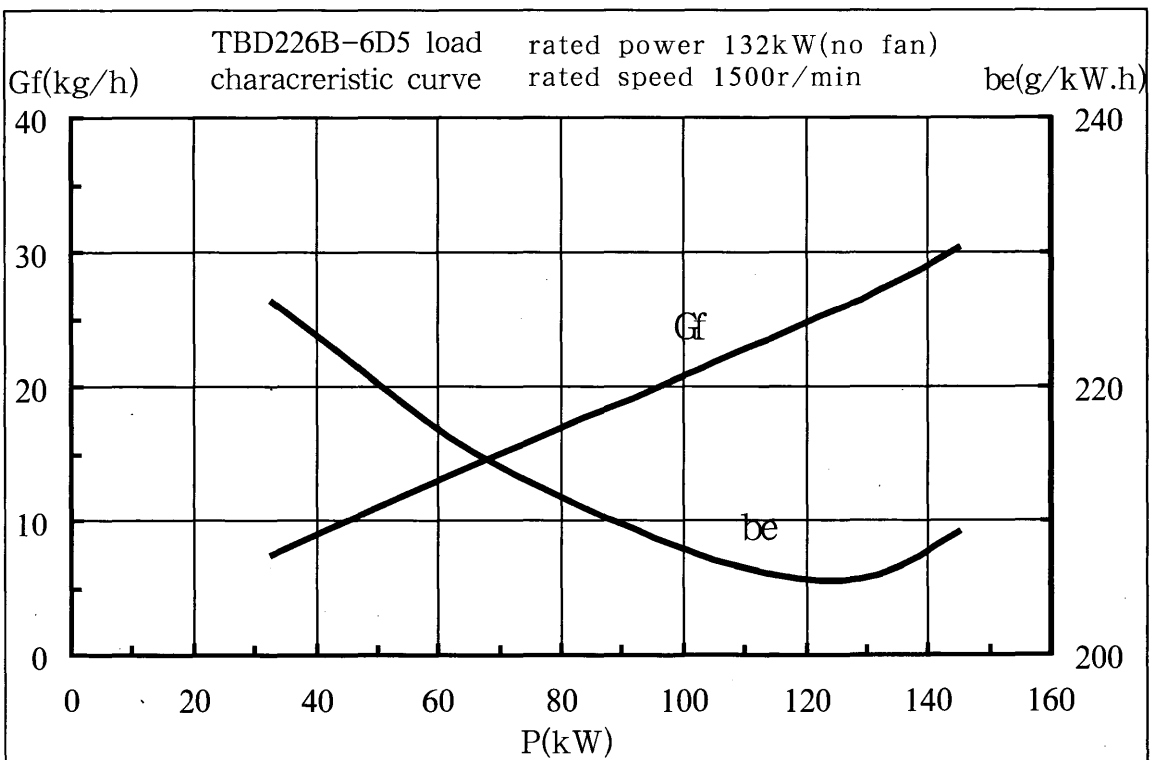
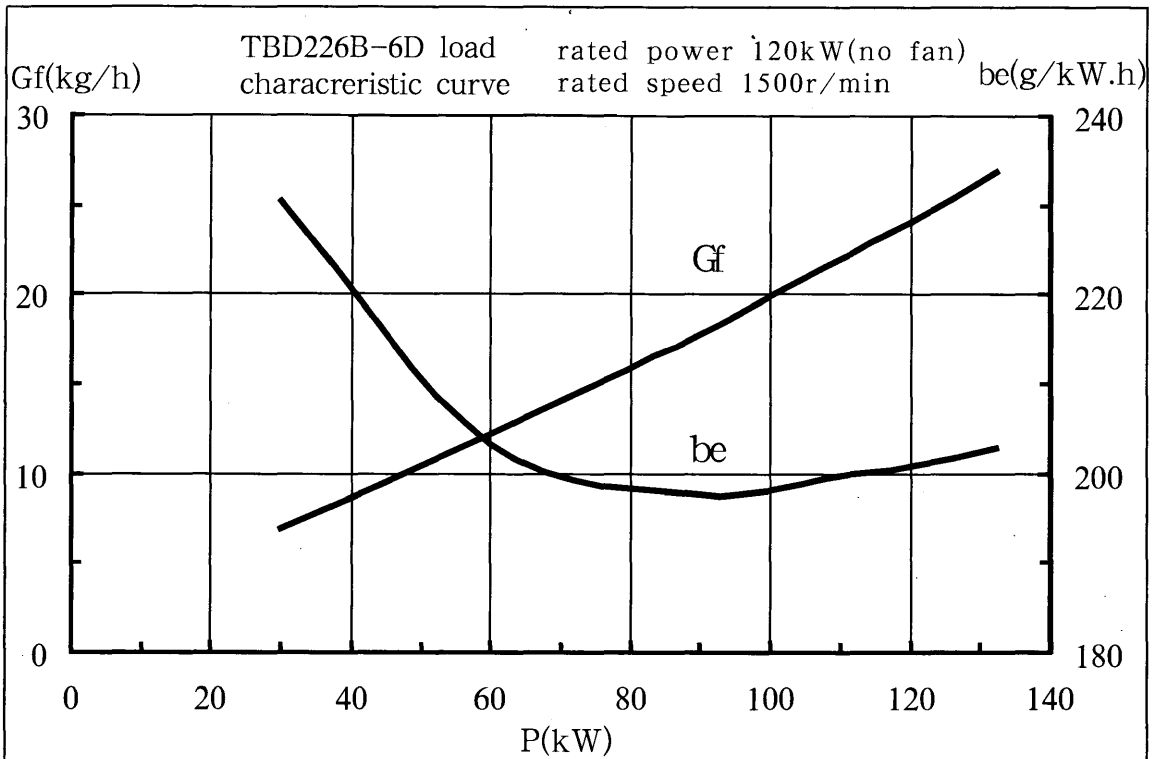

1、Main performance and specifications

Item \ Model	D226B - 3D	D226B - 4D	TD226B - 3D	TD226B - 4D	TD226B - 6D	TBD226B - 6D	TBD226B - 6D5
No. of cylinder	3	4	3	4	6	6	6
Bore/stroke (mm)	105/120						
Displacement (L)	3.117	4.156	3.117	4.156	6.234	6.234	6.234
Type	4 - stroke, water - cooled, in line, DI, wet liner						
Rated power (kW)	30	40	45	60	90	120	132
Rated speed r/min	1500	1500	1500	1500	1500	1500	1500
110% of rated power (kW)	33	44	49.5	66	99	132	145
Speed at 110% of rated power (r/min)	1500	1500	1500	1500	1500	1500	1500
Mean effective pressure at rated conditions (kPa)	770	770	1155	1155	1155	1534	1687
Mean piston speed (m/s)	6	6	6	6	6	6	6
Compression ratio	16.4		15.5				
Cold compression pressure (kPa)	3000 (Min 2500)		3000 (Min 2500)		2700 (Min 2200)		
Min idle speed (r/min)	800 ± 50	800 ± 50	800 ± 50	800 ± 50	800 ± 50	800 ± 50	800 ± 50
Steady governing speed	≤ 5						
Aspiration	Natural aspirated		Turbocharged			Turbocharged and inter - coded	
Firing order	1 - 3 - 2	1 - 3 - 4 - 2	1 - 3 - 2	1 - 3 - 4 - 2	1 - 5 - 3 - 6 - 2 - 4		
Oil capacity (sump) (L)	7.25	9	7.25	9	13	13	13
Oil pressure (kPa)	300 - 550						
Oil pressure at idle (kPa)	≥ 100						
Max permitted oil temp (°C)	≤ 120						
Max permitted water outlet temp (°C)	≤ 90						
Exhaust temp after turbine (°C)	≤ 600	≤ 600	≤ 550	≤ 550	≤ 550	≤ 550	≤ 550
Starting method	Electric						
Permitted gradient longitudinal/cross	25/30	30/40	25/30	30/40	20/45	20/45	20/45
Crankshaft rotation (from freeend)	Clockwise						
Noise dB(A)	≤ 110	≤ 110	≤ 110	≤ 110	≤ 110	≤ 110	≤ 110
Weight (kg)	520	560	530	570	760	780	780
Steady governing speed	For the models that are equipped with electronic governor, the governing speed is no more than 1.5 Refer to electronic governing instruction All of the models above can be installed with electronic governor.						

2、Specifications of main accessories

No.	Name	Model		D226B - 3D	D226B - 4D	TD226B - 3D	TD226B - 4D	TD226B - 6D	TBD226B - 6D	TBD226B - 6D5		
		Item										
1	Injection pump	Type	Multi - cylinder integrated type BQ or type A				Multi - cylinder integrated type AD or A					
		Model	See" Fuel system matching table"									
		Rated speed(r/min)	750				750					
		Rated fuel delivery(mm ³ /cyc)	61	81	88	87	83	106	111			
2	Governor	Type	Mechanical and centrifugal									
		Model	See" Fuel system matching table"									
3	Fuel feed pump	Type	Plunger type									
		Model	See" Fuel system matching table"									
4	Injector	Type	Multi - hole, valve needle									
		Part No.	12270162	12270162	12153057	12270162	12153057					
		Open pressure	See" Fuel system matching table"									
		Nozzle Model	See" Fuel system matching table"									
5	Fuel filter	Type	Spiral paper element									
		Part No.	12270392				13020488					
6	Water pump	Type	Centrifugal(scroll case is on the middle plate)									
		Part No.	12273212				12159770			1273240		
		Impeller diameter(mm)	φ86					φ110				
		Rated speed(r/min)	3000				2210					
7	Oil pump	Type	Gear type									
		Part No.	12166769	12166779	12166769	12166779	121559765					
		Rated speed(r/min)	1700									
8	Crankshaft damper	Type	—	—	—	Rubber type		Silicon - oil type				
		Part No.	—	—	—	12160595		12272805				
		Outer diameter(mm)	—	—	—	φ182—		φ310				
9	Turbocharger	Type	Radial									
		Model	—	—	K14orS150	K24orJ60S - 2		J76DorS2B7623 HH0. 85D9orK27				

Specifications of main accessories(2)

No.	Name	Item \ Model	D226B - 3D	D226B - 4D	TD226B - 3D	TD226B - 4D	TD226B - 6D	TBD226B - 6D	TBD226B - 6D5	
			10	Oil filter	Type	Spiral paper element				
		Part No.	12272453				01174421			
11	Oil cooler	Type	Round plate type							
12	Thermostat	Type	Wax type							
		Open temperature(℃)	75							
		Full open temperature(℃)	90							
13	Starter	Type	DC, self excitation							
		Power	4kW							
		Voltage	24V(12V is optional)							
14	Generator	Type	Three - phase AC, commutated and voltage regulated							
		Part No.	12903819			13020748				
		Power	0.75kW							
		Voltage/current	28V/27A(14V is optional)							
15	Intercooler	Type	—	—	—	—	Air - oiv intercooled	Air - oiv intercooled	Air - oiv intercooled	
16	Water cooler	Type	Air cooled and finand tube type	Air cooled and finand tube type	Air cooled and finand tube type	Air cooled and finand tube type	Air cooled and finand tube type	Air cooled and finand tube type	Air cooled and finand tube type	
		Model(or part No.)	13025078	13025078	13025078	13025078	13024933	13024933	13024933	
		Radiation area (m ²)	20	20	20	20	30	40	40	
17	Fan	Type	Exhaust	Exhaust	Exhaust	Exhaust	Exhaust	Exhaust	Exhaust	
		Part No.	13021367	13020367	13021367	13021367	13021535	13021190	13021190	
		Outer dia(mm)	φ466	φ466	φ466	φ466	φ540	φ600	φ600	

Fuel System Matching Table

Diesel engine Model	TBD226B - 6D	TD226B - 6D	TD226B - 4D	D226B - 3D	TD226B - 3D	TBD226B - 6D5
Injection pump assembly no.	13020436	13021799	13021656	13021938	13022109	13023574
Injection pump model	CPES6AD100 D320RS2139	CDES6AD100 D320RS2140	CPES4AD95 D320RS2152	BH3QT80R9 BH3A95R504	BH3QT85R9 BH3A95R501	BP1213
Governor model	CRSV450... 750ADOC139R	CRSV450... 750ADOC139R	CRSV450... 750ADOC139R	T300 - 750Z TRSV330 - 750A504	T300 - 750Z TRSV330 - 750A501	+ TRSUV 4500 - 750P
Electronic governor model (12V, 24V are optional)	ESG 2000					ESG 2000
	ESG1500C1 - D					ESG1000C1
Supply pump model	SAD/H2206	SAD/H2206	SAD/H2206	SI/HZ2204 SA/H2208	SI/HZ2204 SA/H2208	S505
Fuel delivery advance angle	16 ± 0.5	18 ± 0.5	18 ± 0.5	20.5 ± 0.5	20.5 ± 0.5	14 ± 0.5
Injector number	12153057	12153057	12270162	12270162	12153057	12153057
Injector body model	KBEL90S3/13	KBEL90S3/13	KBEL90S3/13	KBEL90S3/13	KBEL90S3/13	KBEL90S3/13
Injection nozzle model	DLLA151S972	DLLA151S972	DLLA152S1180	DLLA152S1180	DLLA151S972	DLLA151S972
Injection pressure (MPa)	22 ^{+0.3}					
High - pressure pipe	Cuter dia * inner dia (mm)	6 * 1.75				

3. Diesel engine construction

3.1 Cross and longitudinal section view of diesel engine

3.1.1 Longitudinal section view of D226B -4 diesel engine

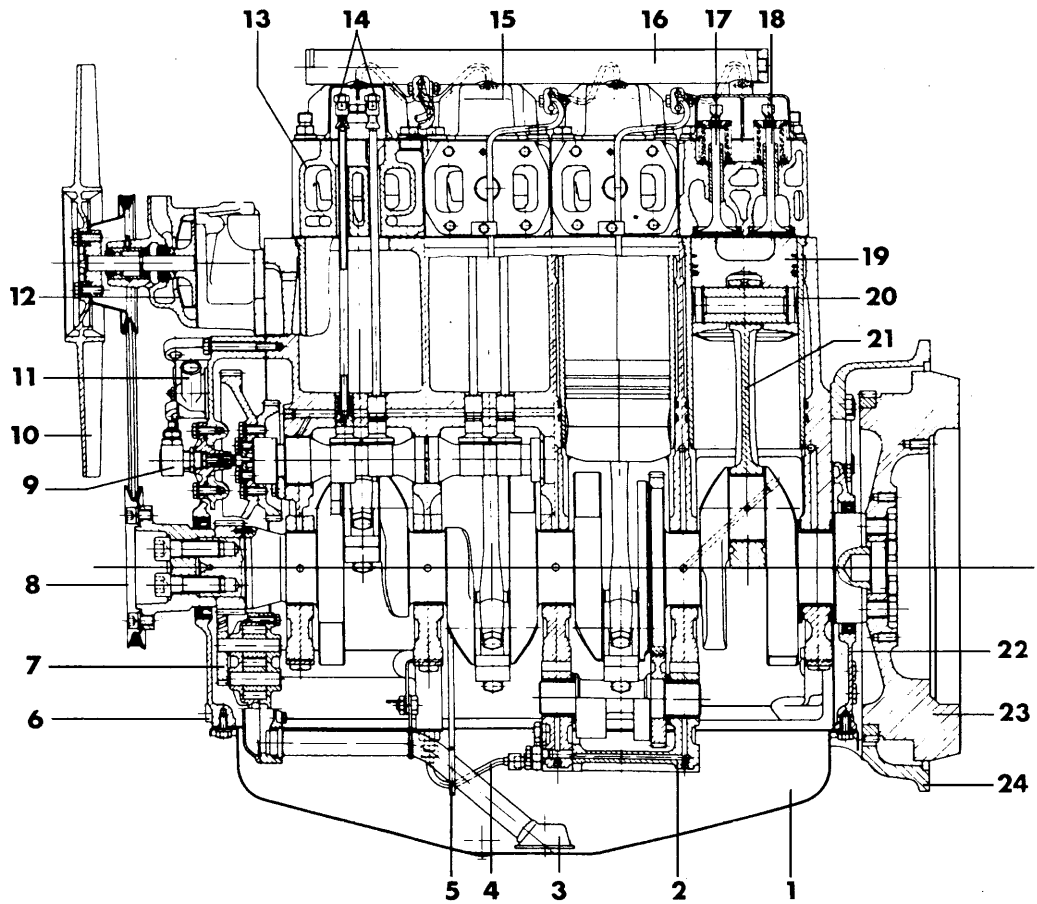

- 1 Oil sump 2 Two - stage balancing mechanism 3 Pre - filter 4 Oil pipe 5 Oil dipstick
6 Gear case cover 7 Oil pump 8 Crankshaft belt pulley 9 Speed sensor (on the flywheel housing)
10 Fan 11 Inspirator 12 Water pump 13 Cylinder head 14 Rocker arm and rocker arm support
15 Cylinder head cover 16 Water outlet pipe 17 Intake valve 18 Exhaust valve
19 Piston 20 Cylinder liner 21 Connecting rod 22 Rear oil seal cover 23 Flywheel
24 Flywheel housing

3.1.2 Cross section view of D226B –4 diesel engine

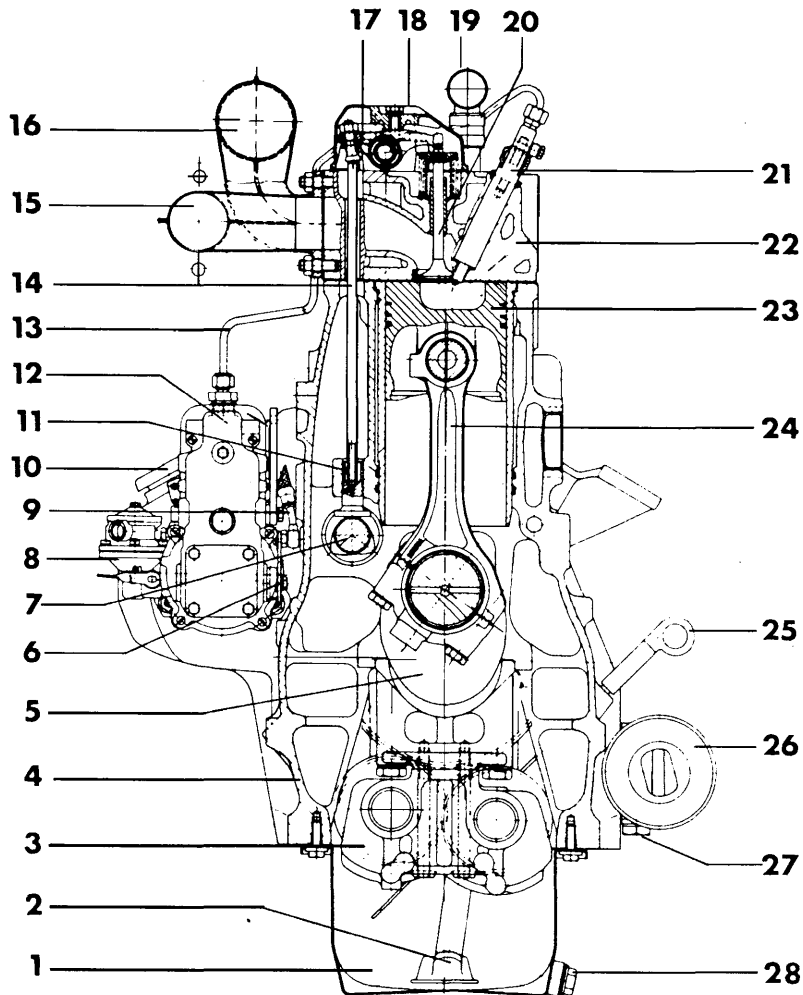

- 1 Oil sump 2 Pre - filter 3 Two - stage balancing mechanism 4 Cylinder block
 5 Crankshaft 6 Engine stop lever 7 Camshaft 8 Fuel supply pump (or piston pump)
 9 Oil pipe(to injection pump) 10 Oil filler (various position) 11 Tappet 12 Injection pump and governor
 13 High - pressure pipe 14 Push rod 15 Exhaust pipe 16 Intake pipe
 17 Rocker arm 18 Cylinder head cover 19 Water outlet pipe 20 Intake/exhaust valve
 21 Injection pump 22 Cylinder head 23 Piston 24 Connecting rod 25 Oil dipstick
 26 Oil filter 27 Safety valve 28 Oil drain plug

Note: For 3 - cylinder and 6 - cylinder engine, there is no two - stage balancing mechanism.

3.2 Cylinder block subassembly

Cylinder block subassembly mainly consists of cylinder block, liner, gear case, rear oil seal cover, flywheel housing and oil sump.

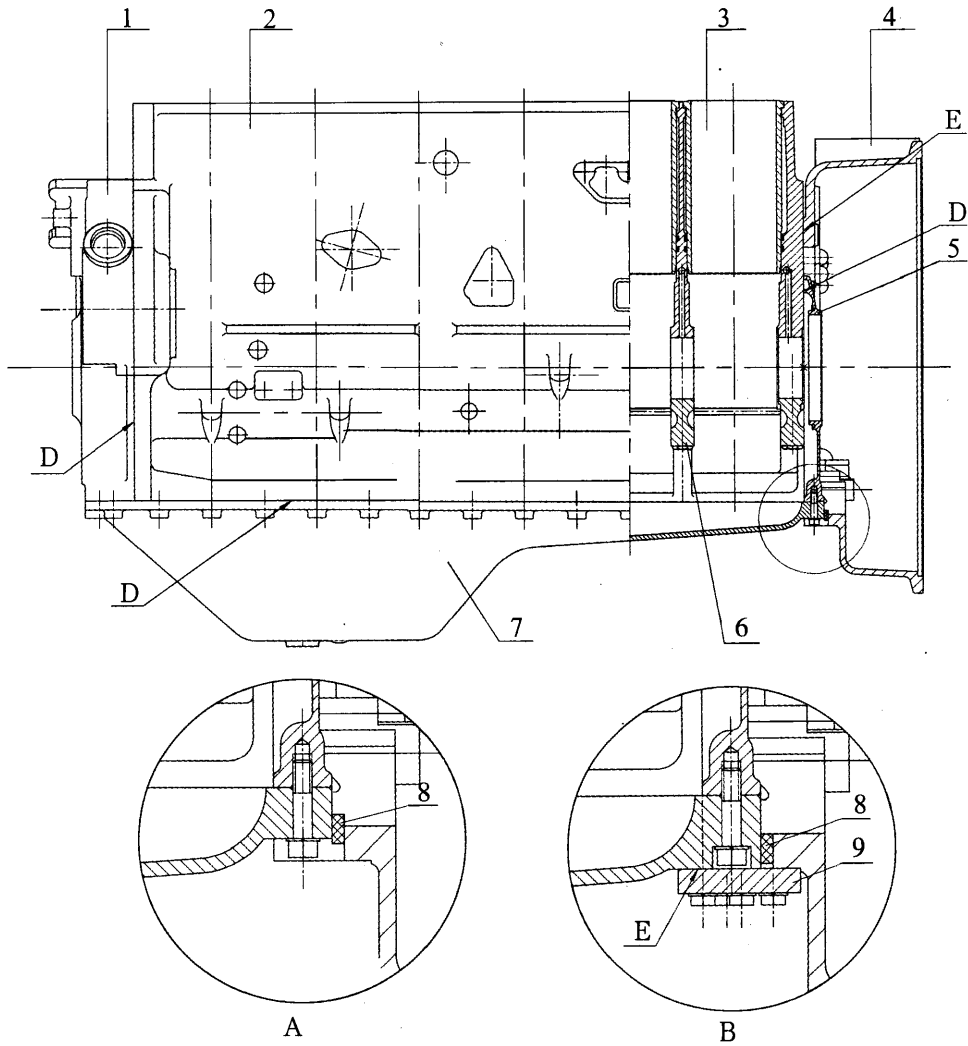

- 1 Gear case(front cover) 2 Cylinder block 3 Cylinder liner
- 4 Flywheel housing 5 Rear oil seal cover 6 Main bearing cap
- 7 Oil sump 8 Seal strip 9 Seal plate

When A structure is adopted, coat seal glue on D joint face; When B structure is adopted, coat seal glue on both D and E joint face.

Fig 1

Cylinder block is made of high – strength cast iron, it has good strength and rigidity. For 3,4 and 6 – cylin-

der engine, cylinder block has 4, 5 and 7 main bearings separately. The thrust ring is fitted on the first main bearing (flywheel end). The main bearing cap is tightened by M14 – 10.9, the torque is about 70Nm and then the cap is turned for 90°. Tightening order is shown in fig 2. First tighten the main bearing in middle, then tighten the bearing on both ends. For camshaft bearing holes in cylinder block, only the last one (free end) is fitted with bronze camshaft bushing. There are two holes in the bushing, one of them is aimed at the oil hole in cylinder block in mounting, another one should be upwards. (shown in fig 3). For turbocharged engine and turbocharged and inter – cooled engine, a jet per cylinder is mounted on the right of cylinder block (viewed from flywheel end) for cooling piston.

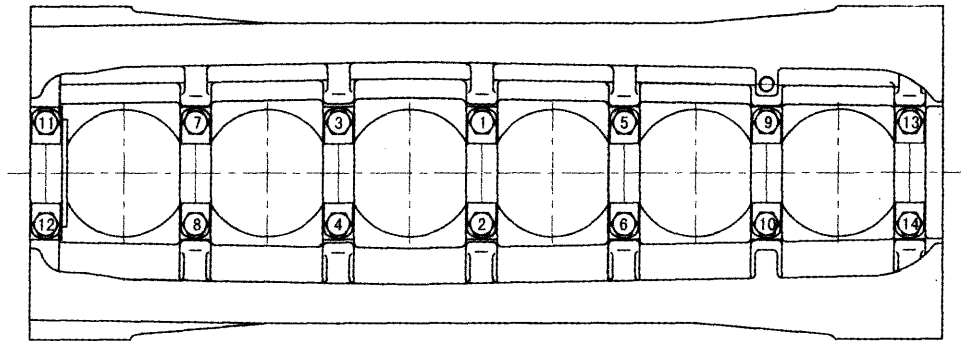

Fig 2

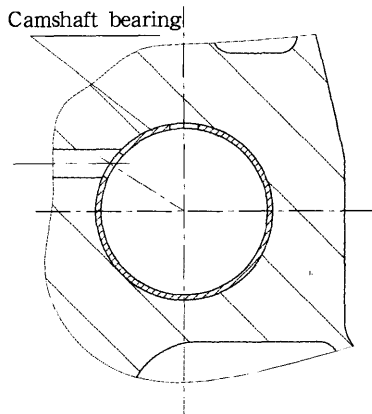

Fig 3

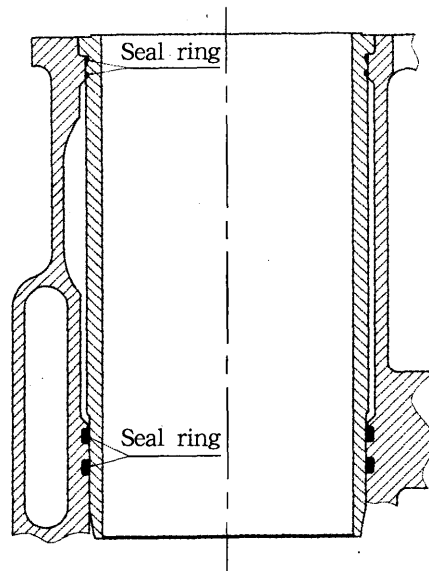

Fig 4

226B series diesel engine adopts wet cylinder liner. In order to guarantee sealing after assembling, there are two rubber seal rings on the upper and lower locating positions of the liner respectively. The lower seal ring is set up in the seal groove on cylinder block and the upper one is set up in the seal groove on the upper end

of cylinder liner.

Before mounting, coat some lubricate grease on the seal rings (Fig. 4).

The front end and rear end of cylinder block are connected with gearbox cover and rear oil seal cover and flywheel respectively. When mounting, coat some Loctite 5910 (or other alternatives of the same charas teristic) sealant on the contact surfaces of gear case cover, rear oil seal cover and cylinder block. The tighten force for gear housing bolts (M8 - 8.8) is about 20 - 25Nm.

There are SAE1 ,SAE2 ,SAE3 and 135C flywheel casings are available for different engines and applications. There is a observation window on the top or the bottom of flywheel casing (fig. 5) for viewing the graduation on flywheel and defining the TDC and adjusting the fuel supply advance angle of injection pump. The flywheel is fastened on cylinder block with M10 - 12. 9 (tighten force: 80 + 5Nm) and M12 - 12. 9 bolts (tighten force: 140 + 5Nm).

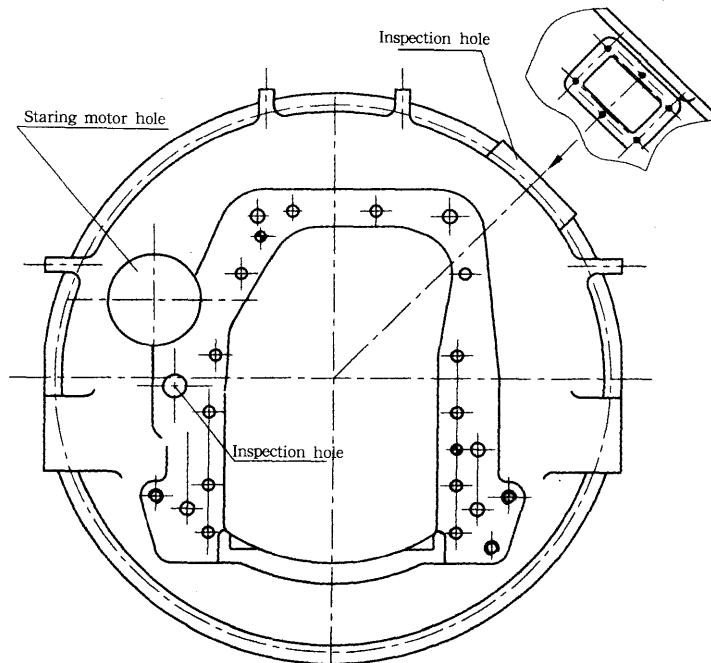

Fig 5

Oil sump has two structural forms: cast and steel - punched. The connecting positions of oil sump and cylinder block, gear case cover and lower bottom surface of rear seal cover are coated with Lotite 5910. It is tightened through M8 - 8.8 bolts. Dust proof plate is fitted between oil sump and flywheel housing. For flywheel with hydraulic converter, because there is oil leakage of hydraulic converter, the flywheel sealing must be guaranteed. So the joint surface between oil sump and flywheel is sealed by sealing plate and coated with sealing glue. (fig 1).

3.3 Crank shaft and connecting rod mechanism

Crank shaft and connecting rod mechanism consists of crankshaft, flywheel, piston, connecting rod, vibration damper, two - stage balancing mechanism (for 4 - cylinder engine only) etc.

Crankshaft:

Crankshaft is forged part, the balancing block is fitted on the crank arm and it is dynamic tested. Timing gear is fitted on the front end of crankshaft, tight fit is adopted. In mounting, timing gear is heated to 250°C and it is aimed at the crankshaft dowel pin. Hub is fitted on the front of gear, and it is tightened through M16 - 10.9 bolts, the force is 240 + 10Nm or M16 - 12.9 bolts are adopted and the force is 300 + 10Nm. Crankshaft front oil seal is mounted between gear case and hub, in mounting, lubricating grease is coated on the positioning face. Another method of connecting timing gear case and crankshaft is pressed by hub directly.

Vibration damper: Vibration damper and pulley are fitted on the hub which is on the front end of the crankshaft, they are tightened through M10 * 8.8 bolts, the force is 45 + 5Nm. While M10 - 10.9 bolts are adopted, the force is 65 + 5Nm. For 6 - cylinder engine, silicon oil damper is adopted, the diameter is 310mm (for engine speed 1500r/min - 1800r/min). 4 - cylinder turbocharged engine adopts rubber damper cast into integral with hub.

Flywheel:

Flywheel is fitted on the rear end of crankshaft, it is tightened by 6 M16 - 10.9 bolts. Pre - tightened by 70Nm and turned for 90°. Different types of flywheel can be adopted according to different matching application and connecting method. On the flywheel, scale plate is stick to the side connecting surface of flywheel and crankshaft. (fig 6) , the mark OT is the TDC mark of 1st and 6th cylinder. For some models, OT top dead center mark and scale is marked on the flywheel circumference, and the inspection window is left on the flywheel side surface.

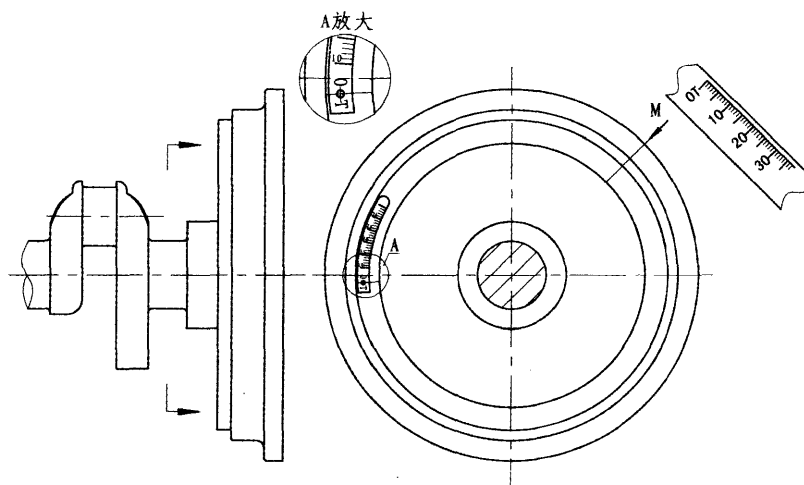

Fig 6

Two – stage balancing mechanism :

In order to balance the two – order reciprocating inertia force of piston and connecting rod subassembly of 4 – cylinder engine and decrease the vibration, two – stage balancing mechanism is adopted. Drive gear ring (1) of transmitting two – stage balancing mechanism is mounted on the crank arm, it should be heated to 250°C in mounting. "0 – 0" mark on gear should be marked on the specified position (fig 7). The mark "1" on the balancing shaft gear (2) of two – stage balancing transmitting mechanism should be matched with the mark "1 – 1" on gear (3). Two – stage balancing mechanism is mounted on the main bearing cap, in mounting, the mark "0 – 0" on gear ring should be matched with the mark on gear (2) of the balancing shaft. The gear side clearance is 0.2mm and can be adjusted by gasket (fig 8). Oil circuit should be unobstructed in mounting so as to ensure the lubrication of two – stage balancing mechanism bearing.

Piston group :

It consists of piston, piston ring , piston pin and lock ring.

For turbocharged and non – turbocharged diesel engine , the piston, piston ring and piston pin are different from each other.

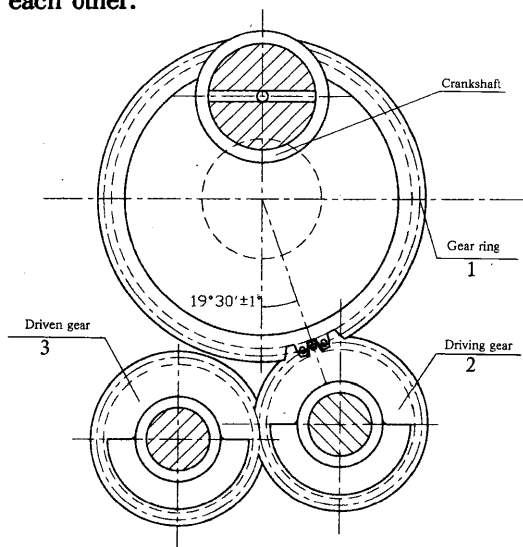

Fig 7

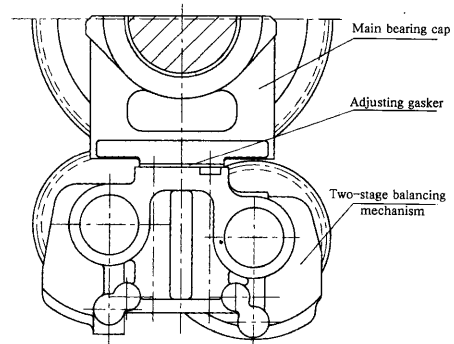

Fig 8

Combustion chamber and piston pin hole are off the piston center, mount the piston according to the right direction. (Fig. 9)

There are three piston rings on the piston. The first ring is of a ladder ring, and the second ring is of cone ring. The face with "TOP" (or factory mark) must be upwards (towards to the piston top) when mounting (Fig. 10). The third ring is of a oil ring with a spiral spring. When mounting, the splits of three rings must be staggered by a angle of 120° from each other, and the angle from the split of first ring to the edge of pin hole must not less than 30°.

When mounting, coat some clean oil on the surface of piston and cylinder liner.

Connecting rod: made through mould forging, composed of connecting rod body, connecting rod cover, small end bushing and connecting rod blot. The big end is 45°sectioned and the mating face is located with 60°tooth. There are two connecting rod bolts (M14 × 1.5 – 12.9). When mounting, tighten them with torque of 30Nm, and then turn 60°once more.

Caution: The connecting rod bolt can be used only once, or the potential fracture of the bolt may cause the damage of the machine and personnel casualty.

The connecting rod body is machined with the cover, and they are not interchangeable. There are mating marks on the body and cover. (Fig. 9)

Connecting rod bearing shell: this bearing shell is made of lead – copper with steel back. The alloy surface is plated with three – part alloy. For strengthened engine (e. g. the engine models of 120kW/1500r/min and 132kW/1500 for power generation), the upper shell is of "quad – alloy – plated layer" with bigger load bearing and anti – fatigue capabilities.

The connecting rod bearing shell is located with a elastic cylindricalpin pin.

Main bearing shell: this bearing shell is made of lead – copper with steel back. The alloy surface is plated with ternary alloy. There are oil grooves on the upper half of bearing shell. The main bearing shell is located with spring pin. The lower half of this shell is of "quad – alloy – plated (optional)" and is corresponding with the connecting rod quad alloy plating, which is mainly applied in high power engine.

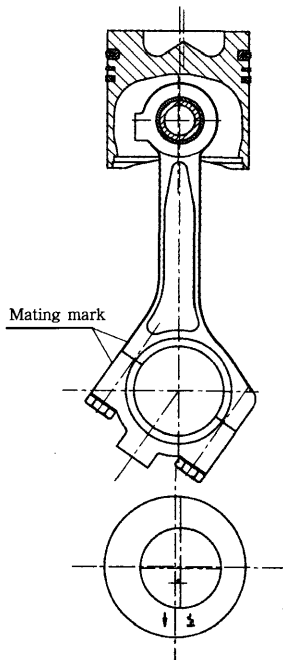

Fig 9

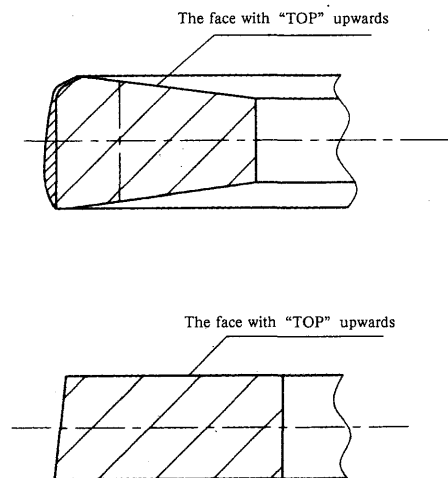

Fig 10

3.4 Gear train

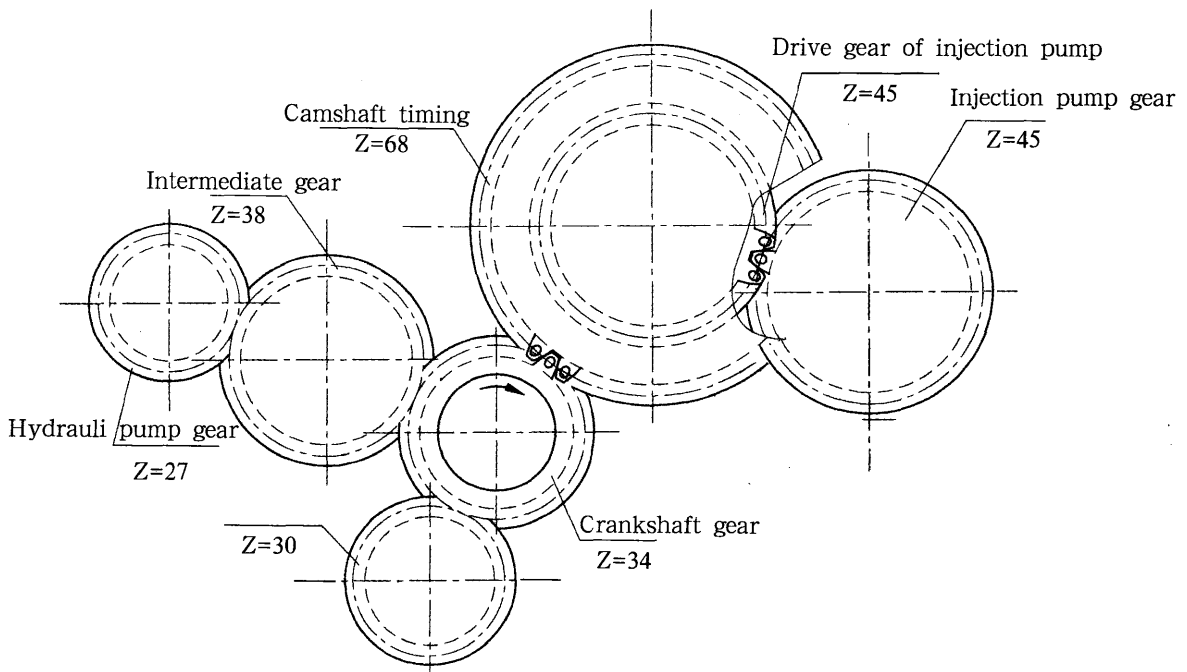

Fig. 11

When the 1st cylinder piston is at TDC, the mark "O" on the teeth of crankshaft gear is corresponding to the "O - O" mark on two tooth of camshaft gear, and the mark "O" on injection pump drive gear is corresponding to the mark "O - O" on injection pump gear (see fig. 11). Camshaft gear is fastened on the camshaft with four M10 × 1.25 - 10.9 bolts, and the four screw holes are uneven distributed for easy aligning of marks on the cam and the gear. The tightening force of these bolts are 85 + 5Nm. Injection pump drive gear is connected with camshaft gear by four M8 - 12.9 bolts, and the tightening force is 85 + 5Nm. Injection pump drive gear and camshaft gear can be moved relatively. If the injection advance angle can't be reached by adjusting the injection pump, change the relative position of the two gears.

3.5 Cylinder head and valve system

Cylinder head: made of alloy cast iron, one cylinder one head (with one intake valve and one exhaust valve). The intake/exhaust ports are at the same side of the head. There is a seat ring on the intake/exhaust port respectively. For turbocharged engine, the intake valve seat cone angle is 120°, and the exhaust valve seat cone angle is 90° (fig. 12). For natural aspiration engine, the intake/exhaust valve seat cone angles are all 90° (fig. 13).

The width of valve seat face: 2.0 - 2.7mm (intake valve seat of turbocharged engine)

1.4 - 2.0mm (other valve seat)

The injector is at the opposite side of intake/exhaust ports and forms an angle of 65° with the bottom face of cylinder head. There are two water outlet ports available. One is on the top face of cylinder head and the other is at the intake/exhaust port flange. The relationship of cylinder heads and diesel engines are as fol-

lows:

Cylinder head part No.	Water outlet position	Intake valve cone angle	Diesel engine structure
12212203	Top face of cylinder head	90°	Natural aspiration, air intake pipe and water outlet pipe are all separate parts
12214114	Top face of cylinder head	120°	Turbocharged, air intake pipe and water outlet pipe are integral cast
12214178	Intake/exhaust port flange	90°	Natural aspiration, air intake pipe and water outlet pipe are integral cast
12214132	Intake/exhaust port flange	120°	Turbocharged, air intake pipe and water outlet pipe are all separate parts

Valve seat/valve guide TD/TBD226B

Valve seat/valve guide D226B

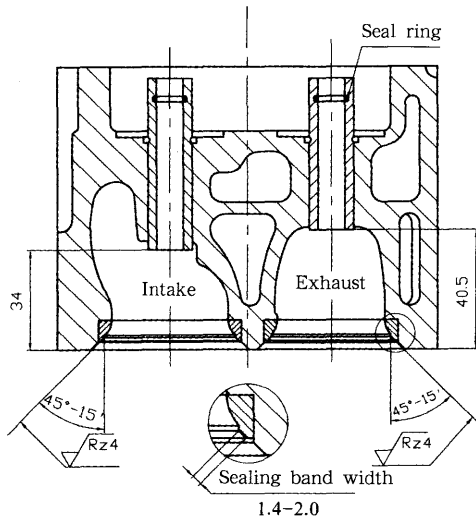

Fig. 12

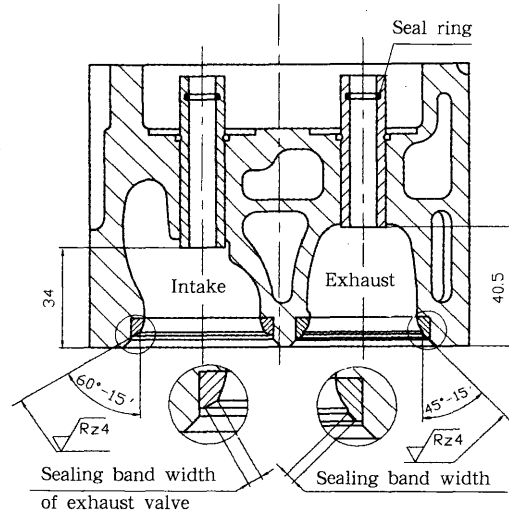

Fig. 13

Valve guide: made of phosphor cast iron, and phosphate coating. Intake valve guide length is 58mm, exhaust valve guide length is 51.5mm. Mounting position of valve guides are shown in fig 12 and fig 13. There are grooves and a rubber seal ring on the inner wall of guide to prevent oil from entering into cylinder.

Valve system: composed of camshaft, tappet, push rod, rock arm, rock arm bracket, valve, valve spring and some accessories.

Oil passage of valve system is shown in fig 14.

The oil came from cylinder block enters into tappet and the spherical surface of push rod through the ring groove on the tappet, and then into the hollow push rod, the rocker arm adjusting screw, the rocker arm and arm shaft to lubricate the friction surfaces of rocker arm and valve.

Cold clearance of valve:

Inlet valve clearance: 0.2mm; exhaust valve clearance: 0.3mm.

Valve timing when the valve clearance is imm, Acceptable clearanle:

$\pm 3^\circ$.

Intake valve open: $0^\circ 45'$ CA after TDC

Intake valve close: $8^\circ 15'$ CA after BDC

Exhaust valve open: $32^\circ 45'$ CA before BDC

Exhaust valve close: $0^\circ 15'$ CA before TDC

Coat some clean oil on the surface of camshaft hole in cylinder block before mounting the camshaft. The fan-like stop plate for camshaft should be mounted. The stop plate is fixed with two M8 – 12.9 bolts, it's tightening force is $55 + 5\text{Nm}$.

When mounting, coat some oil on the surfaces of rocker arm and rocker arm shaft. Rocker arm bracket is fixed with M10 – 8.8 bolt, tightening force is $40 + 5\text{Nm}$. Lock up the rocker arm adjusting screw (M9 \times 1) with a nut by force of $20 + 5\text{Nm}$.

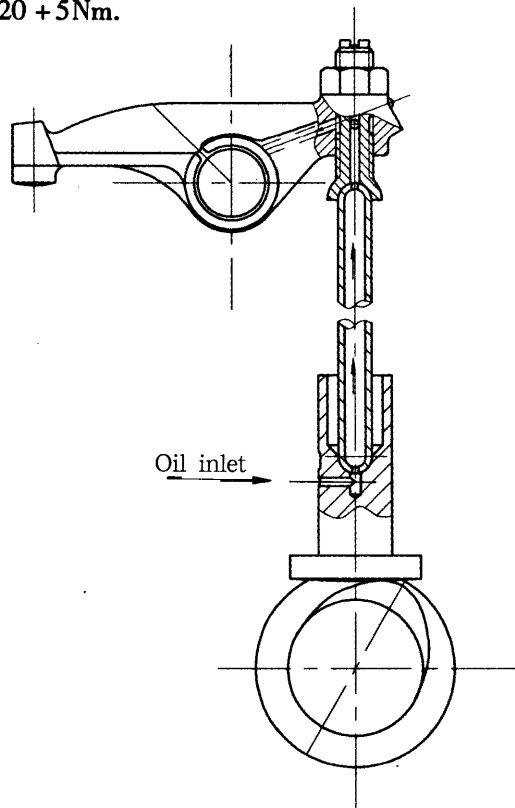

Fig. 14

Valve: The valves for turbocharged and natural aspiration engines are made of different materials, they can not be used interchangeably. For turbocharged engine, the valve rod and valve head are made of different materials. All valve rods are chrome plated. After the valve is assembled on the cylinder head, the valve sinkage is about 1.03 – 1.42mm.

After cylinder heads are mounted on cylinder block, all intake/exhaust flanges must be on one plane to ensure the sealing of intake/exhaust manifold. Cylinder heads is fixed with four M14 ÷ 12.9 bolts coated with oil (molybdenum disulfide is not permissible). The bolts should be tightened according to the sequence in Fig 15 by 3 times. First, tighten up with a force of 30Nm, then turn the nuts through an angle of 120°, and then turn the nuts through another angle of 120°.

Caution: The cylinder head bolt will be elongated by 0.2 – 0.6mm. If the length from the end of the bolt to the support face is up to 160.5mm, the bolt must be changed.

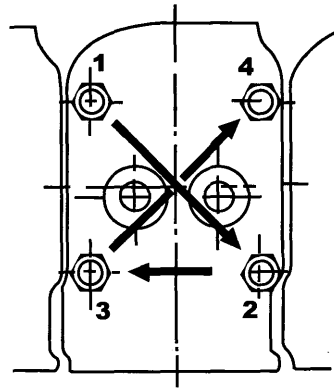

Fig. 15

3.6 Fuel supply system

Fuel supply system is composed of injection pump, governor, fuel supply pump, fuel filter, injector, high pressure pipe, low pressure pipe and some accessories. (Fig. 16)

Injection pump and governor assembly:

Generally, injection pump, governor and fuel supply pump fall into one assembly. 226B diesel engine adopts type AD and P Bosch injection pump and type RSV governor, some other types of injection pumps and governors are also adopted (see "Fuel system matching table").

There is a mounting flange on the end face of injection pump and there is an O – ring on the end face stop. The injection pump is fixed with 4 studs, and tightening force is 35 + 5Nm. When mounting of injection pump gear, the mark "O" on injection pump gear should be faced with the "O – O" mark on the drive gear for injection pump (fig. 11).

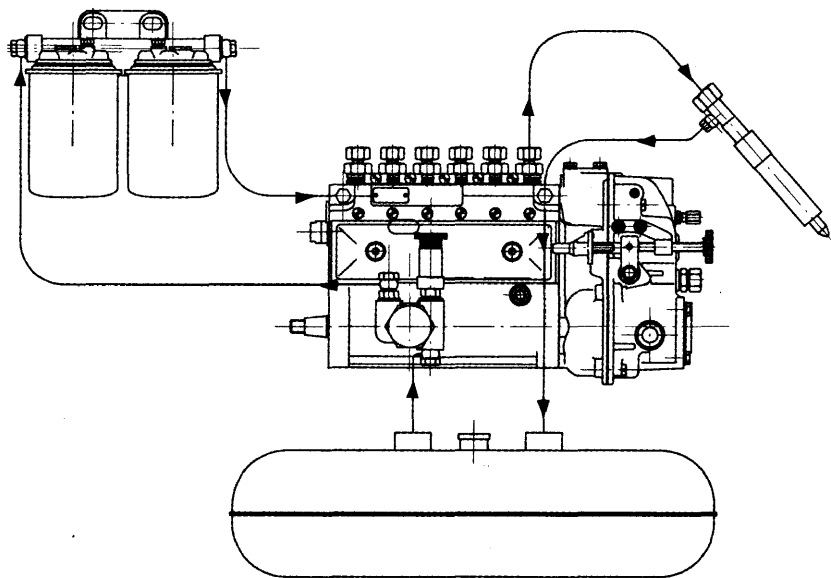

Fig. 16

Check and adjusting for delivery beginning.

Correct delivery beginning can enable the engine to obtain good performance. The crankshaft angle can be determined by measuring the displacement which the piston from TDC, also it can be done by making use of the flywheel mark. It is recommended to use the former method for more precision.

When determining with the piston displacement, you should:

(1) Turn the crankshaft to let the piston of cylinder next to the gearcase end at TDC position of compression stroke (the intake & exhaust valves are all closed).

(2) Dismantle the rocker seat.

(3) Dismantle the valve spring of intake valve or exhaust valve. The valve head falls on the piston in the meantime.

(4) Set the dial gauge 1 with clamp at the top of valve stem. (see Fig. 17)

(5) Turn the crankshaft along CW and CCW directions to measure the position of piston at TDC, and dial the hand of dial gauge to 0 graduation.

(6) Turn the crankshaft along the contrary direction to its working direction, and let the valve drop to not more than 15mm.

(7) Pull control handle 4 to the middle position. (see Fig. 18)

(8) Dismantle the delivery valve 5 of injection pump and mount the overflow pipe 6. (see Fig. 19, 20)

(9) Get rid of the air in fuel piping with the hand pump of delivery pump until no bubble spills from the overflow pipe.

(10) Pay attention to the moment of fuel dropping from overflow pipe while turn the crankshaft slowly along its working direction. Stop turning crankshaft as soon as the dropping occurs, and the crankshaft angle is the very position of delivery beginning for this cylinder. The delivery beginning angle can be found in the relationship between crankshaft angle and piston displacement (see Appendix 1) by comparing it with indicated value on the dial gauge.

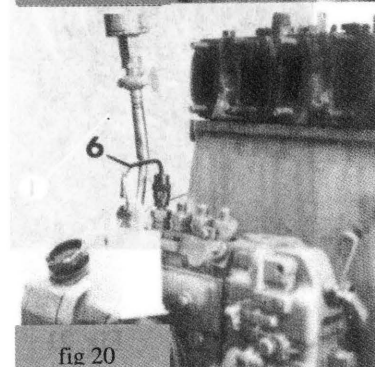
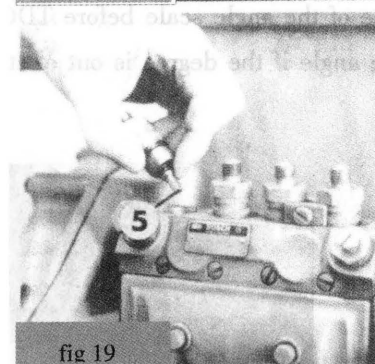
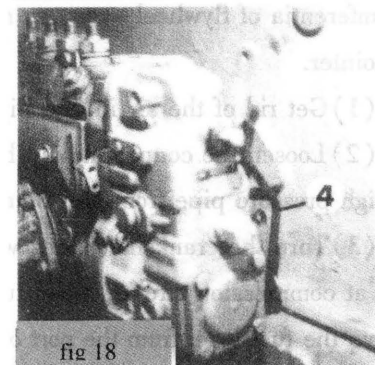
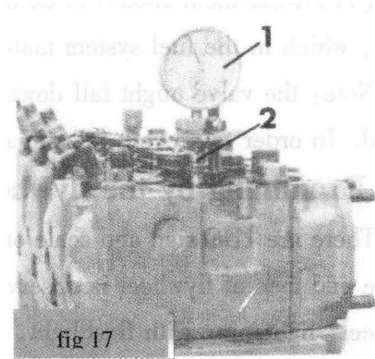

Fig. 17, 18, 19, 20

(11) Adjustment should be done if the measured angle differs from the required fuel supply advance angle, which in the fuel system matching table.

Note: the valve might fall down into the cylinder if the turning angle is too big when the crankshaft is turned. In order to prevent this situation occurring, clamp ring can be mounted in the groove of valve stem.

Examining by the flywheel mark:

There are TDC sign and scale on the end face or circumferentia of the flywheel (see Fig. 6). The scale on the end face of flywheel is observed via the round hole 1 (see Fig. 21) below the starting motor on the flywheel, lightening with flashlight, you can read the scale at the center of the circle. For the scale on the circumferentia of flywheel, you can read it via the side window 2 on the flywheel housing (see Fig. 22) and the pointer.

(1) Get rid of the air in fuel piping.

(2) Loosen the connecting nut between the high – pressure pipe and fuel pump at the gear end, divorce the high pressure pipe from fuel pump.

(3) Turn the crankshaft along working rotating direction and make the piston of 1st cylinder (flywheel end) at compression stroke, when turning continuously near delivery beginning, you should slow down and observe the fuel level from the port of delivery valve holder, stop turning as soon as the level rises. Read the degree of the angle scale before TDC from the flywheel, adjustment should be done to the fuel supply advance angle if the degree is out of standard.

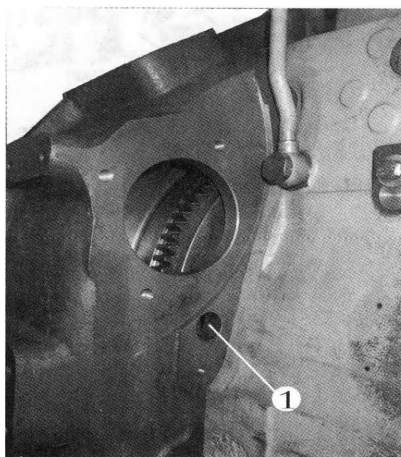

Fig. 21

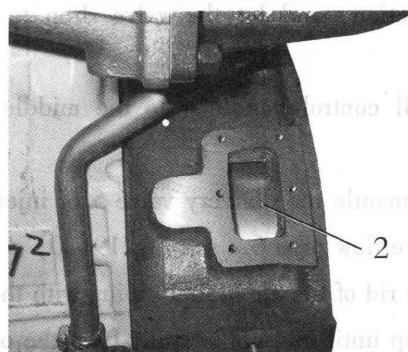

Fig. 22

How to adjust fuel supply advance angle:

Loosen the tightening nut of the injection pump flange, and turn the pump. The fuel supply advance angle increases when the top end of injection pump is turned towards cylinder block, and the angle decreases when doing in reverse. Check according to the above method after adjusting, and readjust until the advance angle meet the stated requirement.

The fuel supply advance angles for different models of diesel engine are listed in Fuel System Matching Table.

Relationship among plunger diameter of injection pump, speed of engine and the fuel supply advance angle :

diameter of injection pump	speed of engine (r/mm)	fuel supply advance angle
9		1500 ~ 1800
9.5		21
10		18
11		16
		14

Injector assembly :

BOSCH S type nozzle is adopted for the diesel engine. Nozzles differ from each other in the number of orifices, orifice diameter and angle of spray according to different requirements of the engines. See Fuel System Matching Table for details.

The fuel rough filter should be set before the fuel entering into delivery pump from fuel tank to protect the delivery pump and the fuel fine filter.

3.7 Lubricating system

The schematic diagram for lubricating system :

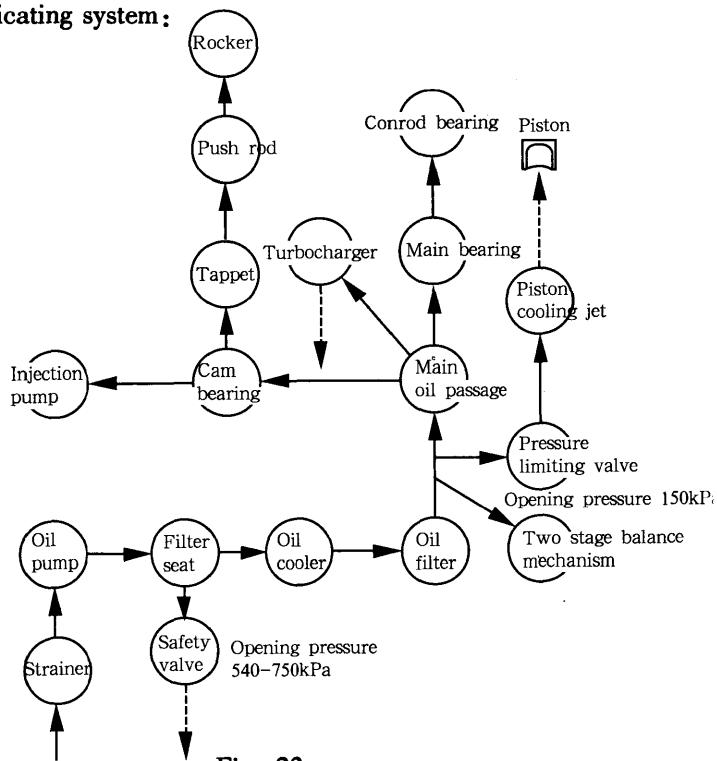

Fig. 23

The lubricating system consists of strainer, oil pump, oil cooler, oil filter and pressure limiting valve

etc.

The strainer is the intake opening of the oil pump, the connection between it and the inlet of oil pump is sealed by O – ring, and special attention should be taken to avoid leakage during installing the connector, otherwise the air sucked in the oil pump will influence oil supply so as to result in severe accidents like bearing burning and engine damage. The oil pump is of gear pump. The pumped oil from oil pump enters into the filter seat which has a safety valve (opening pressure is 540 – 750kPa) on it. The oil will be vented to oil sump when the pressure of oil pumped from oil pump exceeds the opening pressure value of safety valve. There are sockets on the filter seat for pressure sensor and oil cooler. The oil cooler is connected in series with the oil filter at the filter seat. The oil enters the oil cooler from filter seat, through the oil filter and returns the filter seat, then enters the main oil passage. Each finned oil cooler has 9 cooling chips, according to the actual need of different model, only one cooler can be used for the engine, also two or three coolers can be used in series. If the engine – mounted oil cooler can't meet the requirement of oil cooling for the engine, user may adopt out – connected cooler, but the filter seat 12273108 with oil inlet & outlet joints should be used instead of the former seat. The oil filter is of spin – on type, and can be used only once. In the lubricating system, pressure lubrication is adopted for the main bearing, connecting rod bearing, cam bearing, two stage balance mechanism bearing, rocker bearing, injection pump, turbocharger, air compressor etc. , and splash lubrication is adopted for the connecting rod small end, gear train, piston, cylinder liner etc.

3.8 Cooling system

Besides becoming kinetic energy to do work, the heat energy produced by the fuel burning in the combustion chamber of the engine also heats up the cylinder head and cylinder liner etc. , therefore coolant cooling should be used to prevent them from overheating and guarantee the engine to work reliably in order.

3.8.1 Schematic drawing of the cooling system

The supercharged: inter – cooled diesel engine is equipped with supercharging air cooler(intercooler) , which is positioned between the fan and radiator.

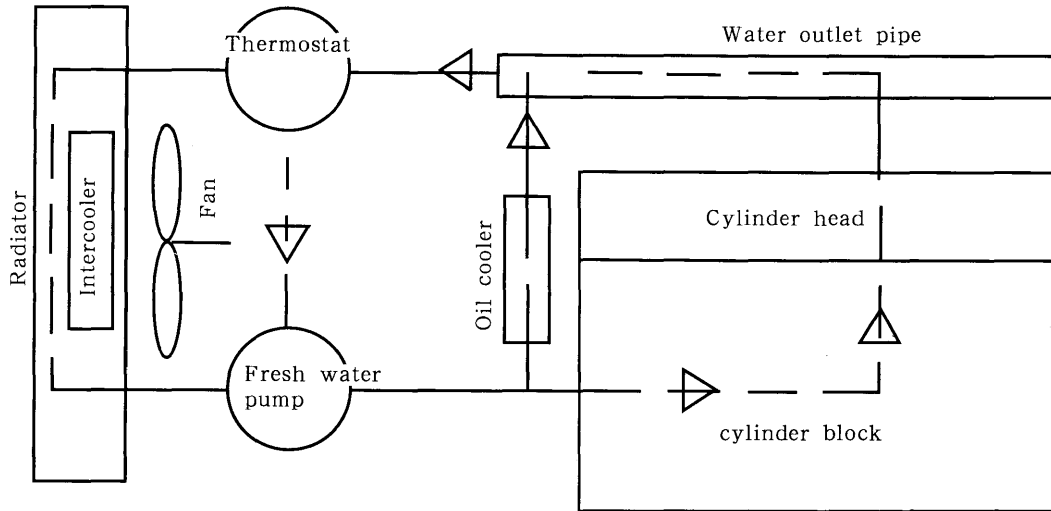

Fig. 24

3. 8. 2 Main components of cooling system

Water pump: the pump is of centrifugal type. The vortex passage of water pump is settled at intermediate gasket, the water pump is integrated with the intermediate gasket and mounted at the front end face of cylinder block. The cooling water enters into cylinder block through intermediate gasket. The impeller diameter of water pump is 86mm or 110mm. Water pumps with different sizes should be chosen according to the applied speed and requisite cooling flow of the diesel engine.

Water outlet pipe: the structure of water outlet pipe has two forms, one is welded part; and another is cast part connected with intake manifold, the latter is applied to the following arrangement, i. e. the water outlet of cylinder head is located at the flange surface of intake and exhaust ports, and the adopted built-in thermostat inside the water outlet pipe. **There is vent pipe (dia: 6mm) at the top of the water outlet, this pipe should be connected with expansion tank or the cavity of upper water chamber of radiator, gas in the cooling system is guided out via this pipe to prevent water overheating due to air resistance.**

Thermostat: there are two kinds of thermostat types, one is outboard type and another is built-in type. Its opening temperature is 75°C. When the outlet temperature of cooling water is lower than opening temperature of the thermostat, the cooling water enters into water pump via the outlet for minor circulation of thermostat, and the temperature of cooling water is quickly raised to reach the water temperature which the diesel engine needed under normal operation; when the temperature of outlet water is higher than opening temperature, the thermostat opens till full opening, all or partial cooling water enters the cooler to be

cooled, and then enters into water pump.

Radiator and fan: (the radiator is supplied according to user's contract)

The radiator is fin and tube radiator, its capacity is configured according to the quantity of heat removal. The fan is made of pressed metal sheet or extruded plastic; its diameter is 466, 520, 540 and 600mm. The fan can be mounted on water pump.

3.9 Intake & exhaust system

This system includes air cleaner, intake manifold, exhaust manifold, exhaust muffler, exhaust turbo-charger (for turbocharged diesel engine), intercooler (for turbocharged and intercooled diesel engine) and connecting pipes.

3.9.1 Intake

The intake air for the engine should be clean and enough, therefore the intake air must be filtered and the resistance in intake pipeline should be as small as possible.

Dry type paper element air cleaner is applied to 226B diesel engine for generating. The air cleaner with corresponding capacity should be chosen for the engine with different power, and the cleaner with different model should be chosen according to the dust content of ambient air in actual working site.

The dye type paper element filter usually has primary filter (it can make the air produce swirling flow), paper cartridge and safety element, as well as auto dust – extracting valve or exhaust arresting device installed after the primary filter to take off the dust from filtering. The resistance of the air cleaner should not be too big, the allowable max. resistance under its unstained condition is 3kPa, and that under its stained condition is 5kPa. **There is maintenance indicator mounted at the vent port of air cleaner, when red signal is given that means maintenance or replacement should be taken place in time, otherwise the performance and service life will be influenced.**

In mounting the air cleaner and connecting pipe, users should pay attention to its sealing and reliability. Otherwise largely increased oil consumption, crankcase blow – by, decreased engine power, black smoke exhaust and so on would occur because that the filter lose its effectiveness and is in short circuit leading early wear of the engine and could not achieve the specified service life. It even causes the serious wear of cylinder liner and piston ring, and breakage of piston ring and cylinder scuffing.

The intake manifold of the engine is jointed by plates or cast by aluminum alloy, and there are various structures for it to satisfy the requirements of different diesel engines. When the intake manifold is mounted to the cylinder head, compound material gasket is used to aluminum manifold, while stainless steel gasket is used to jointed manifold. **The stainless steel gasket should be mounted with its convex surface facing to the cylinder head. The tightening torque for tightening nut of intake manifold is $45 \pm 5\text{Nm}$.**

3.9.2 Exhaust

The three – cylinder or four – cylinder diesel engine adopts unitary exhaust manifold, and the six – cylinder engine adopts inserted exhaust manifold which is made up of two parts (every part for three cylinders) and sealed with narrow width ring. **The joint between exhaust manifold and cylinder head is sealed with stainless steel gasket, the convex surface of which should face to the cylinder head. The torque for tightening nut is $45 \pm 5\text{Nm}$.**

The exhaust resistance of diesel engine should be as small as possible; therefore the exhaust manifold must have sufficient diameter or area and with bends as few as possible, because the performance of engine will be influenced obviously if the exhaust resistance exceeds a certain value. The sum of the resistances of exhaust main and muffler should not be more than 7.5kPa for natural aspirated engine, and not be more than 5kPa for turbocharged engine.

In order to lower the surface temperature of exhaust manifold and for safety reason, the exhaust manifold should be wrapped with heatproof material and covered with armor plates, and high temperature caution sign as well. In addition to that, some of the engines adopt water jacket exhaust manifold.

Because the surface temperature of the rear exhaust pipe, muffler, and expansion joint is very high, external prevention measures should be provided. The exhaust gas of the engine contains nitrogen oxides, hydronitrogen, oxycarbide and carbonic smoke particle. Frequently breathing in those exhaust gas or particles in large amount will do harm to human, so such exhaust gas should be kept away from the personnels.

3.9.3 Turbocharging and inter – cooling system

Turbocharger: Both turbocharging models and the turbocharging inter – cooling models of the 226B series engine employ the radial flow exhaust turbocharger. See the accessory list for the those models. The oil lubricating and cooling the turbocharger flows into the turbocharger from the main oil passage then directly back into the crankcase.

The exhaust turbocharger is a kind of running mechanism at its high speed and high temperature. The immediate halt when the engine is running at high speed and with large load is strictly forbidden. The right way is to decrease the load and the speed gradually and let the engine run idly for another 5 – 10 minute so as to avoid any damage to the turbocharger bearing. After the turbocharger is disassembled, some clean engine oil should be put at the oil inlet during the mounting process.

Charging air cooler (intercooler)

The temperature will go up after the air goes through the turbocharger and gets pressured. The intercooler of the 226B turbocharging inter – cooling engine features: air – air cooling. is used to lower the pressured intake air temperature.

Air – air cooling intercooler (delivered conforming with the contract), generally speaking, is assembled together with the circulating water radiator, cooled by fan. The intercooler can be placed in front of or at the back of the radiator, determined by the wind direction of the fan. The intercooler could also be placed in line with the radiator, determined by the overall fitting mechanism.

The maximum acceptable flow resistance (supercharger to intercooler/ intercooler to engines) when the pressured air from the supercharger is passing through the pressure pipe should be less than 2kPa. The flow resistance while going through the intercooler should be less than 5.0 – 5.5 kPa. So the limit value of the total resistance when the pressured air is passing through pressure pipe and intercooler is 7.0 – 7.5(kPa).

3.10 Electrical system

The system is consisted of starter, chargeable generator, control instrument and storage battery. The service voltage is 24V or 12V, subject to the choice of the customers.

Starter: The starter is a DC motor controlled by electromagnetism. Without specific requirement, the rated power is 4kW at the working voltage of 24V and 2.7kW at the working voltage of 12V.

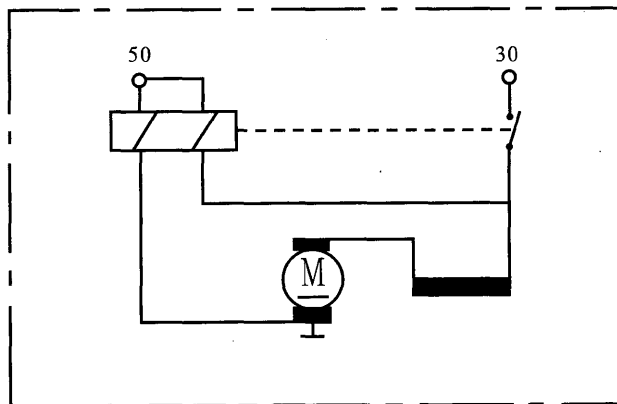

Fig 25 Schematic diagram of the starter

Generator: The generator is a kind of silicon rectifying generator equipped with transistor adjustor. The rated voltage is 28V or 14V. The generator is connected parallelly with the storage battery. The generator is self – excited when working.

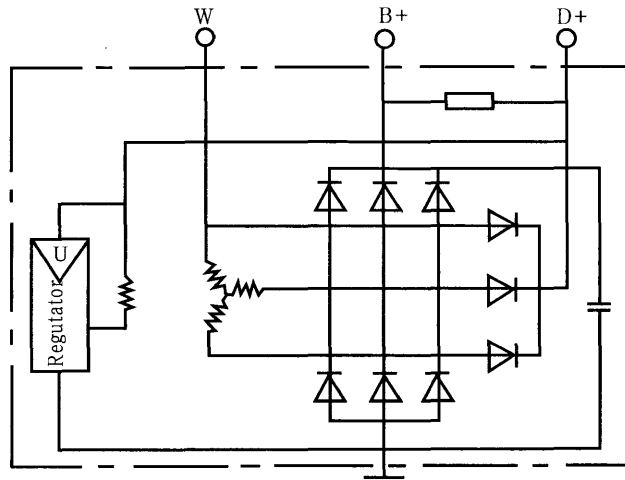

Fig 26 Schematic diagram of the generator

Storage battery (generally self – prepared by the customers)

Storage battery capacity

Cylinder quantity	Starter voltage V	Storage battery capacity Ah
3,4	24	66
3,4	12	88
6	24	88
6	12	110

Monitoring instrument: The monitoring meter is an automatic diesel engine monitoring system, which can accurately display the speed, oil pressure, water temperature and oil temperature. It can make timing monitoring to above parameters according to the setting of the customers and send signals like sound warning, light warning and distant transmitting. There is interface on the monitoring meter, through which a remote monitoring meter can be connected (they must be used together). The monitoring instrument is delivered according to the contract. Refer to the monitoring instrument instruction for detailed information about it.

Schematic diagram of the electric circuit connection

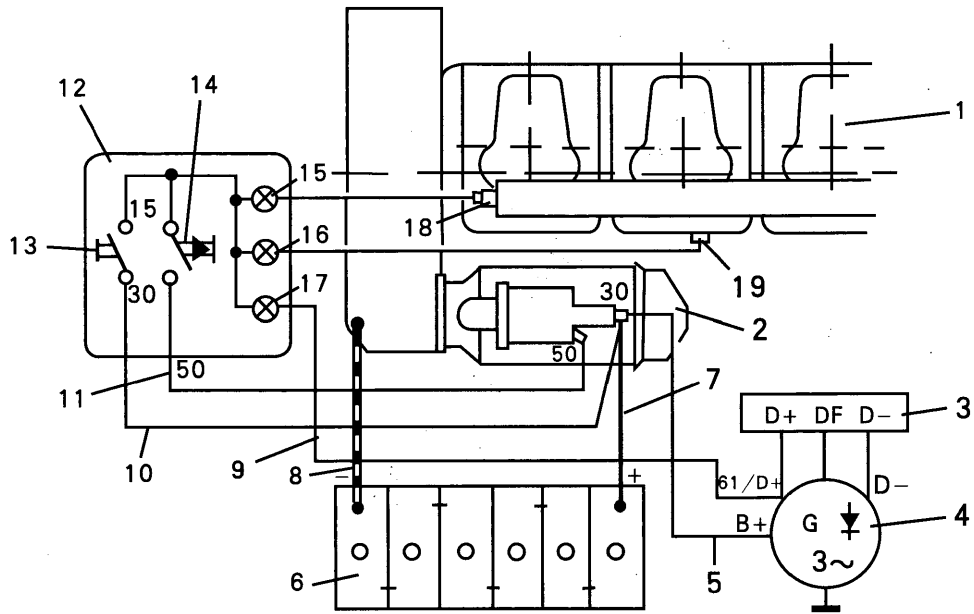

- | | |
|---|--|
| 1. diesel engine | 11. connecting wire from starting button |
| 2. starter | 12. meter cover |
| 3. adjustor of the generator | 13. ignition lock |
| 4. AC generator | 14. starting button |
| 5. the connecting wire from the AC generator to starter | 15. temperature warning light |
| 6. storage battery | 16. oil pressure warning light |
| 7. the anode connecting wire to the starter | 17. charging indicator light |
| 8. earth wire | 18. temperature sensor |
| 9. connecting wire from starter to charging indicator | 19. oil pressure sensor |
| 10. connecting wire from starter to ignition lock | |

3.11 Main bolts tightening torque

No.	Name of bolt	Specification	Tightening torque (Nm)	
			Maximum (max)	Minimum (min)
1	Cylinder head bolt	M14 - 10.9 M14 - 12.9	Pre - tighten with a torque of 30Nm, turn 120°, then again turn 120°.	
2	Main bearing bolt	M14 - 10.9	Pre - tighten with a torque of 70Nm, turn 90°	
3	Tightening nut of intake pipe and exhaust pipe	M10 - 10	45	50
4	Flywheel pipe	M16 - 10.9	285	295
5	Fastening boss of crankshaft boss	M16 - 10.9	240	250
		M16 - 12.9	300	310
6	Fastening bolt of the pulley on the boss	M10 - 8.8	45	50
		M10 - 10.9	65	70
		M12 - 8.8	85	90
7	Fastening bolt of the dampener	M10 - 8.8	45	50
		M10 - 10.9	65	70
8	Tightening bolt of the camshaft gear and the fastening bolt of camshaft gear and fuel injection pump gear	Durlok M8 - 12.9	55	60
		M10 * 1.25 - 10.9	85	90
9	Fastening bolt of the mounting gear at the oil injector camshaft	M14 * 1.5	85	100
		M18 * 1.5	100	110
10	Connecting rod bolt	M12 * 1.5 - 12.9	Pre - tighten with a torque of 30Nm, turn 60°	
11	Fastening bolt of the flywheel housing and other fastening bolt and stud bolt	M12 - 12.9	140	145
		M12 - 10.9	110	120
		M10 - 12.9	80	85
		M10 - 10.9	60	65
12	Fastening bolt of oil pan, hexagon cylinder - head bolt for bearing the oil pan.	M8 - 8.8	20	25
		M8 - 10.9	30	35
13	Fastening bolt of two stage balancing mechanism	M10 - 8.8	35	40
14	Fastening bolt of oil pump and the stud bolt with self - locking nut	Durlok M8 - 12.9	30	40
		M8 - 8.8	20	25

15	Construction bolt of rocker arm support	M10 – 8. 8	40	45
16	Adjusting nut of rocker arm	M9 * 1	20	25
17	Fastening bolt of cylinder head housing	M8 – 8. 8	10	15
18	Fastening support for tightening the oil injection pump delivery valve		33	37
19	Fastening bolt of high pressure fuel pipe	M12 * 1. 5	20	25
		M14 * 1. 5	20	25
20	Fastening nut of oil injector	M8	10	15
21	Fastening bolt of hydraulic pump	M10 – 10. 9	60	65
		M8 – 10. 9	30	35
22	Fastening bolt of AC generator pulley	M14	35	40

4. Operating requirement and procedures

4.1 Rules on the working fluid and the auxiliary material

4.1.1 oil

Quality class: Oil is classified according to its quality and characteristics, usually on the basis of API. Oil which is allowed to use

API class: CC, CD, CD - II, CE

CC class oil should be selected for non - supercharged diesel engines while the CD class oil for the super-charged ones. It is allowable for the low - quality oil to be replaced with high - quality oil.

Viscosity

The viscosity of the oil is, to a great extent, determined by the temperature. Refer to the right figure for appropriate oil viscosity class (SAE class).

Please refer to the right figure for the oil viscosity and select the most appropriate oil. The situation where the environment temperature is close to the temperature limit will have some influence on the cold start performance but not necessarily damage the diesel engine.

Do not exceed the temperature limit for long time so as to keep the abrasion within a minimum extent.

Multi - class oil could be used so that it won't be necessary to change the oil during the seasonal alternation period.

The fuel consumption rate could be lowered by using multi - class oil (light oil especially)

It is recommended to use 15W/40 oil when the environment temperature is above -15°C and use 5W/30 when it is below -15°C.

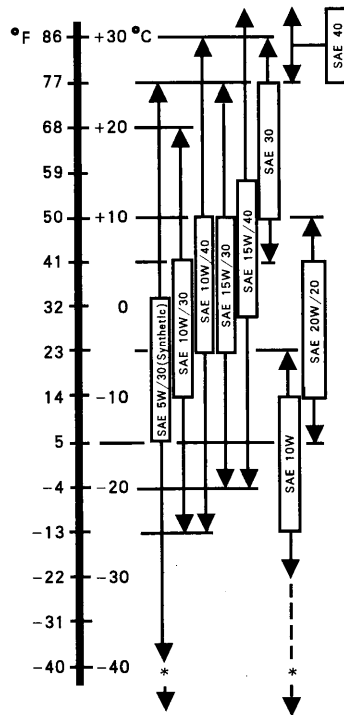

4.1.2 fuel

This engine makes use of light diesel as the fuel.

Quality grade

Sulfur content of specified brand fuel is not allowed to exceed 1%.

The fuel with following brand numbers is permissible:

- DIN 51601
- NATO CODES F54, F57, F76
- BS 2869: A1, A2 (pay attention to the sulfur content of the A2)
- ASTM D975 - 81: 1 - D, 2 - D
- W - F - 800C; DF - A, DF - 1, DF - 2

The waxiness produced by the diesel under low temperature will lead to the low fluidity of the diesel and the blockage of the fuel system and eventually result in the operating failure of the diesel engine.

So please use winter diesel when the environment temperature is below 0°C.

When the temperature is between -15°C and -20°C, the diesel engine could employ a mixture of diesel and kerosene to meet the low temperature requirement. Refer to the right figure for the mixing ratio.

In the case that the summer diesel has to be used at a temperature of below 0°C, some kerosene which do not exceed 60% could be added, as is illustrated in the figure below.

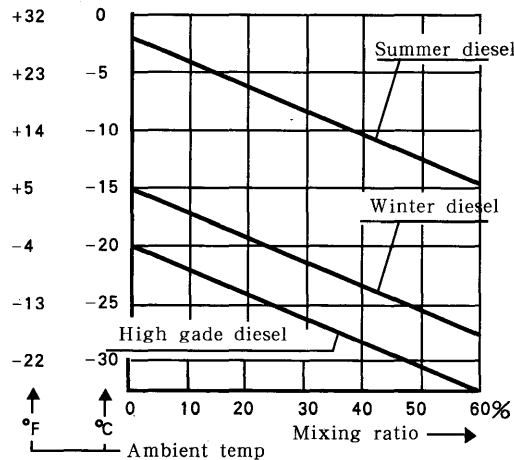

Notice: the mixing process should be proceeded in the fuel tank. Fill in some diesel before adding enough kerosene.

4.1.3 cooling fluid

The cooling water of the diesel engine must be soft water and anticorrosive agent and anti-freezing agent must be added.

Anti-freezing fluid

Please refer to the anti-freezing fluid instruction for the mixing ratio of the longacting anti-freezing fluid.

Longacting anti-freezing fluid

Glycol content %	33	50	56
Density(15.6°C)	1.05	1.074	1.082
Boiling point°C	104.5 ± 1	108.5 ± 1	110.0 ± 1
Freezing point°C	-18 ± 1	-36 ± 1	-45 ± 1
Min. temperature appropriate °C	-10	-26	-35

The concentration of the anti - freezing agent should be checked once every 1000 hours. But there should be at least one checkout in every season. The anti - freezing agent should be changed every two years so as to avoid corrosive damage.

Anticorrosive agent

Anticorrosive agent can be added to the cooling water when the environment temperature is above 5°C (in summer or autumn or in some areas with relatively high temperature).

Cooling water

The compositions of the cooling water are analyzed as following:

Water quality	min.	max.	
PH value	6.5	8.5	Only the water with the compositions of specified content can be added with addition agent
The content of chloride ion (mg/dm ³)	-	100	
Content of carbonate (mg/dm ³)	-	100	
Content of overall anion (mg/dm ³)	-	150	
Degree of hardness when using the anti - freezing agent	3	12	
Degree of hardness of the carbonate	3	-	
Degree of hardness when using chemical anticorrosive agent	Notice the instruction of the supplier		
	0	10	

Inner zinc - plated pipe is not appropriate for containing chemical anticorrosive agent so it cannot be used as cooling water pipe.

4.1.4 Treating of waste fuel/oil

Waste fuel and oil should be stored in a special container. Because there exist poisonous substances in fuel, oil and coolant, drink or contact with skin is forbidden.

4.2 swinging requirement

Inappropriate swinging might damage the diesel engine during the conveying process.

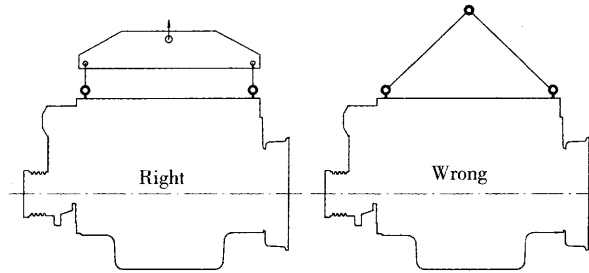

B

It is inappropriate to use a rope and a triangle to sling the engine up. Because if the slings, the cylinder head bolt and the swinging ring are not kept in a line, the cylinder head bolt might be damaged or even fractured during the swinging process, which may eventually result in the failure of the engine.

4.3 Preparation before the start

Notice: The engine should not be started until it has been installed in a appropriate way and placed in a final position. If the engine is operated in a closed environment, make sure there is good ventilation and that the exhaust gas is discharged into the atmosphere.

4.3.1 Engine oil filling

1. The oil must meet the specified requirement, otherwise, the oil pressure might fall short resulting in abrasion and starting difficulty. The oil must be very clean.
2. Screw down the oil - draining plug
3. Open the oil cap and fill in the oil. The oil must be filtered through a dross filter when it is filled in.
4. Put the engine at a level position; pull out the dipstick to examine the height of oil level. Fill the oil up to the upper limit of the dipstick, if necessary.
5. Screw down the oil cap.

Notice: The height of oil level must be checked out every time before starting the engine.

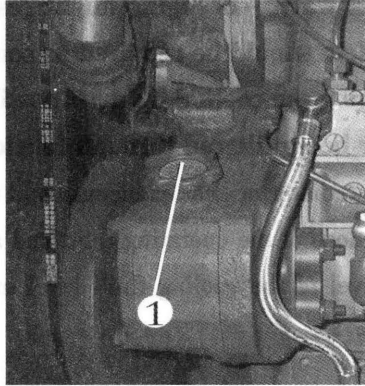

4.3.2 Filling in the fuel

1. The diesel being used must comply with the regulation.

2. Pay attention to the cleanness of the diesel; it had better be stored for at least 72 hours before being filled into the engine. The diesel should be filled into the tank through a build – in dross filter.

Notice: The diesel level should be checked every time before starting the engine.

4.3.3 Deflation of the fuel system

1. Unloosen the fuel bolt 1 (at the fuel outlet of the fuel supply pump) for half a round. Pump with the hand pump 2 of the fuel supply pump 3 until there is diesel coming out; screw down the fuel bolt.

2. Open the deflating bolt 4 on the fuel filter 5. Pump with the hand pump of the fuel supply pump until there is diesel coming out; screw down the deflating bolt.

3. Open the deflating bolt 6 on the fuel injection pump 7. Pump with the hand pump of the fuel supply pump until there is diesel coming out; screw down the deflating bolt.

4. Continue pumping with the hand pump and check whether there is leakage in the fuel pipe, then screw down the hand pump.

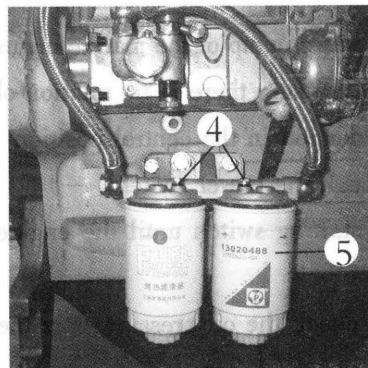
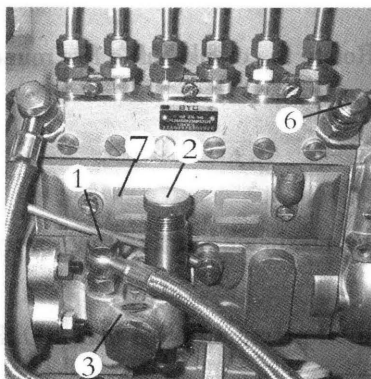

4.3.4 Filling in cooling fluid

The cooling fluid is compounded with softened clean water and anticorrosive agent (or anti – freezing agent). The whole compounding process must be proceeded strictly in accordance with the regulations set by the

manufacturer.

Notice: Frequent water – adding and water – changing might result in the existence of the incrustation. The leakage of the cooling system should be repaired as soon as possible. Add clean soft water as much as possible and avoid changing the cooling fluid, if possible. The cooling fluid drained from the water tank can be recycled after being filtered through fabric and fine structure mesh. Fill in the cooling fluid from the water inlet of the radiator or heat exchanger and discharge the air of the cooling cycling system. Refer to the 4. 1 for the regulations of the operating fluid and auxiliary material, if there is a need to add anti – freezing agent. The liquid level of the cooling fluid level must be checked out every time before starting the engine.

4.3.5 The charging of the storage battery

Refer to the storage battery instruction.

Notice: The gas produced during charging process is quite explosive. So it is forbidden to smoke around the battery. Keep any open fire and spark away from the battery. The acid of the battery has strong corrosivity. If it is splashed in the eye or on the skin, wash them with large amount of water immediately.

The operating sequence of charging process

1. Open the sealing cover.
2. Fill into sulfuric acid from the filler port until the surface reaches the marker.
3. Fasten the sealing cover
4. Coat the electrode of the battery with anticorrosive grease
5. Connect the connecting rod with the binding post, connect the anode first
6. It is not allowed to place any metallic object on the battery
7. Check the sulfuric acid surface every day. Add distilled water if necessary.

4.4 Start

Infuse the raw water pump of the marine engine with water. Rotate the crankshaft a few round before starting the engine to make sure there is no rotation obstruction.

1. Put the speeder rod in the central position
2. Connect through the power switch
3. Turn on the starting switch until the engine is started (The maximum starting time every time is 6 second).
4. Immediately check the oil pressure after the starting. If the oil pressure is less than 100kPa, stop the engine and get rid of the failure.
5. Warm the engine up before operating at full load, check the cooling fluid circulation and whether the oil pressure is normal.
6. Check the Three Leakage condition every time after the operation of the engine.

Notice: When the engine is running, it is not allowed to remove the cables which are connected to the voltage regulator and the battery anode. Differing from the DC generator, it is forbidden to go through voltage checking on the AC generator by the means of temporary earthing.

4.5 Speed regulating

On the engine whose speed is variable, the engine speed can be increased by turning the speeder rod in the direction shown in Fig 2. Screw out blocking nut 3 and loosen the locknut 4 to carry out idle speed regulation. It is not allowed to open the lead sealed cover 5. The speeder rod 1 can be pulled by pull rod or coated steel wire.

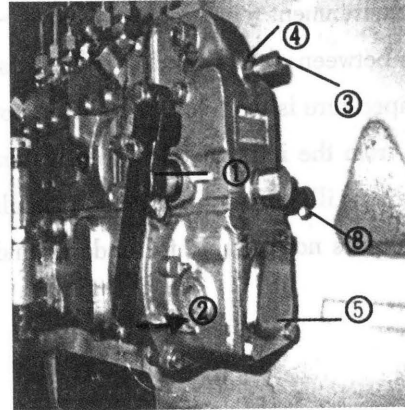

4.5.1 Speed fine – regulating mechanism

The speed fine – regulating mechanism is used to the fixed – speed engine.

Unloose the blocking 7, rotate knurled screw 6 to regulate the speed; turning clockwise will increase the speed, while turning counterclockwise will decrease it. Lock the nut 7 after speed regulating.

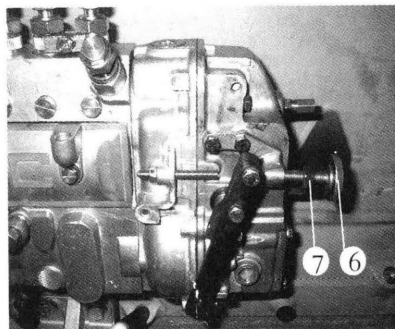

4.6 stopping the engine

Do not try to stop the engine at full load. Decrease the speed before stopping the engine and let it run idly for another 5 to 10 minutes. When trying to stop the engine manually, press the stopping rod 8 downwards until the flywheel stops rotating or the instrument board indicates "zero". Engine stopping mechanism, if using electromagnetic valve, the engine will stop two minutes after the switchover from "open" to "close". Shut the power off after the engine is stopped.

As for the engine whose circulating water is not added with anti – freezing fluid, in winter the cooling water must be drained off after the engine is stopped so as to prevent the engine from being damaged. Dewatering outlet is on the oil cooler. The water inside the engine can be drained away by screw out water –

discharging bolt. At the same time, the water – discharging bolt of the inter – cooler (regarding the super-charging inter – cooler engine) should also be screwed out to drain away the water inside the inter – cooler.

4.7 Operating environment

If the environment temperature is above -15°C , the engine can be operated in a normal way. If the temperature is between -15°C and -35°C , it should be started with the help of auxiliary device. If the altitude or the temperature is too high, the engine power should be modified. The engine is not anti – explosive , so keep it away from the inflammable explosive environment.

The ambient illumination for engine should be more than 20lux.

The engine is not suitable for underground operation.

5. Maintenance

5.1 Time table for Maintenance

There is no need to repeat after following the maintenance schedule

Working items	Operating time h	
Re – tighten the connecting bolt and cylinder head bolt	30	
Check the belt and tension	30	125
Change the oil and oil filter element	30	125
Check valve clearance	30	125

Repeat the maintenance procedure following the timetable below

Working items	Operating time h		
	250	500	1000
Clean up the air filter element 1)	x		
Check and tension the V belt	x		
Change the oil and oil filter element	x		
Check valve clearance			x
Change the fuel filter element		x	
Clean up the crankcase ventilation mechanism 2)		x	

1) The change should be made earlier in dusty place.

Wet air filter should be cleaned every 200 hours (at most).

2) Only under the circumstances where the crankcase ventilation mechanism does not intake the air.

The maintenance instructions for the backup condition and emergency.

If the diesel engine does not operate for weeks (eg, in winter), it must be sealed up (see 5.2.11).

Time period	Requirement
Every month	Trial running with load see 5.2.10
6 months	If the running time does not reach 500 hours after 6 months, the required maintenance procedure must be carried out during this period.
After 12 months	If the running time does not reach 1000 hours after 12 months, the required maintenance procedure of this period must be carried out during this period.

Overhaul

The reliability of the engine might be affected because of abrasion and corrosion. In order to avoid any working abnormality of the engine, we recommend the following overhaul. The first overhaul should be proceeded after the engine has runned for 2000 hours or after two years(running time less than 2000 hours).

Items	Running time
Check the nozzle	2000
Check compressive pressure	2000
Check bearing clearance of the water pump	5000
Check supercharger	5000
Check fuel injection pump	5000
Check cylinder head	5000
Check cylinder liner	5000
Clear the water jacket space of the water cooling exhaust pipe and check the corrosion	10000
Check connecting rod and main bearing	10000
Check piston	10000
Check the crankshaft	10000
Check the camshaft	10000
Check the two – stage balancing mechanism	10000
Check the drive gear	10000
Overhaul fuel injection pump	10000
Change oil pump	10000
Change water pump	10000
Change the oil sealing of the crankshaft	10000
Change the damper	10000

Above overhaul require expertise and should be carried out by professionals.

5.2 Maintenance procedure

5.2.1 cleaning up dry air filter

When the maintenance indicator of the filter shows a red signal or the engine performance is affected because of the resistance of the filter, clean the filter or change the filter element.

1. Dismount the main filter element
2. Lay the end surface downwards and flap the filter element carefully. Or put the filter element on clean ground and roll it to shake the dust off. Do not beat it forcibly.
3. Blow from the inside and outside the surface of the filter element with compressed air (less than 500kPa).

4. clean up the sealing packing. It should be changed if there is any damage.
5. check the dust outlet in the dust - discharging valve.
6. Reinstall. If the filter is mounted horizontally, place the dust - discharging valve vertically downward when mounting the cover.



Notice: The main filter element of a filter can only be cleaned up for at most 5 times. It must be changed after a year, and should be immediately changed if there is a damage. Mark the number of times which the main filter element has been cleaned or changed for in the exclusive marking column of the safe filter element. The safe filter element must be changed under following circumstances:

- 1) Main filter element has been maintained for 5 times.
- 2) It has been used for 2 years.
- 3) As soon as the main filter element is maintained, the maintenance indicator will show immediately.
- 4) After the operation with a defective main filter element.
- 5) Safety filter element is not allowed to be cleaned.

5.2.2 Check connection bolt

Check the bolts for diesel engine, generator, injector and intake/exhaust manifold and the connection of bolts and hoses, retighten them if necessary.

5.2.2.1 Tighten cylinder head bolts

Loosen the cylinder head bolts about 1/4 of a rotation when engine warming, and then tighten them up with a force of 200 + 10Nm immediately according to the sequence as the following figure.

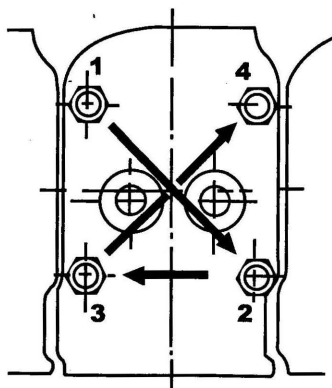

5.2.3 Check and tension the V – belt

Press the V – belt with hand, the distortion should not be more than 10 – 15mm, otherwise change the belt with a new one.

If tension the belt through generator, loose bolt 1 and bolt 2 firstly, strain the generator outwards, then tighten up bolt 1 and bolt 2 and check the belt by hand.

If tension the belt through tension pulley, loose the bolt 3 and bolt 4 on bracket 5, strain the tension pulley bracket, and then tighten up bolt 3 and bolt 4 and then check the belt by hand.

Caution: Change the damaged or oiled belt.

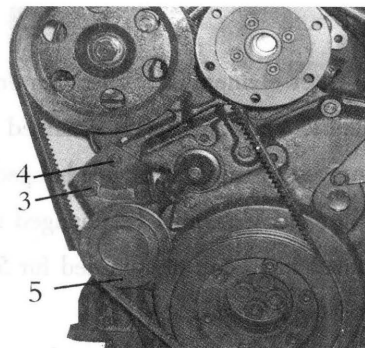
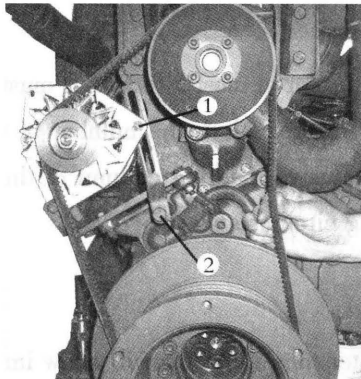

5.2.4 Change oil

- a. Start the engine and stop it after reaching the operation temperature.
- b. Place an oil tank under the engine.
- c. Screw out the drainage screw plug 1, pay attention the seal ring on the screw plug.
- d. Drain off all oil.
- e. Screw on the screw plug 1 with seal ring.
- f. Fill up clean oil.

5.2.4.1 Replace oil filter

- a. Disassemble the oil filter 1 with special wrench.
- b. Coat some oil on the seal ring 2 and tighten up the oil filter by hand.
- c. Check the oil filter for tightness in running – in.

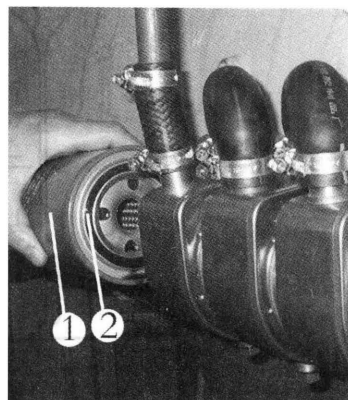
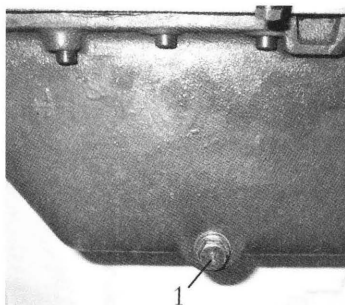

5.2.5 Check valve clearance

- a. Remove cylinder head cover.
- b. Make the piston reached the firing TDC.
- c. Check the clearance between rocker arm and valve rod end with a 0.2mm or 0.3mm feeler gauge 1. Adjust the clearance according to the following steps if necessary.
- d. Loose nut 2, adjust the clearance with screw 3.
- e. Holding the position of screw 3 and tighten nut 2.
- f. Check the other clearances with feeler gauge 1.
- g. Set up rocker arm cover and tighten the screws. The rocker arm cover seal side should be faced with the gasket.

Caution: Adjust valve clearance according to the firing order to avoid turning crankshaft unnecessarily.

5.2.6 Change fuel filter

- 1 Close the valve on fuel circuit.
- 2 Turn the special tools of fuel filter counter – clockwise. Disassemble the fuel filter 1.
- 3 Before mounting new filter, coat lubricating oil on seal ring 2.
- 4 Tighten the new filter by hand.
- 5 Open the valve on fuel circuit.
- 6 Degas the fuel system.
- 7 Check the sealing of fuel filter.

5.2.7 Clean breather body

- 1 Loosen the hexagon nut or screw 1.
- 2 Loosen hose clip 2.
- 3 Disassemble breather body 3.
- 4 Pay attention to the O seal ring.
- 5 Clean the breather body in diesel.
- 6 Mount the breather body, change new O seal ring if necessary.
- 7 Tighten the hose clip 2.
- 8 Tighten the hexagon nut or screw 1.

5.2.8 Clean intercooler

In the operation of intercooler, if enlarged cooled air resistance and the decreased difference in temperature affect the performance of diesel engine, the intercooler should be cleaned.

5.2.9 Run – in

If the engine is in standby or emergency state, run it once a month so as to prevent it from corrosion damage.

- 1 After starting, check the instrument meter at once, put 1/3 load on the engine.
- 2 After running for 10 minutes, increase to 3/4 load.
- 3 After running for another 10 minutes, increase to full load.
- 4 Check the sealing of the engine.
- 5 Run the engine at 1/3 load for 10 minutes.
- 6 Unload and stop the engine.

5.2.10 Engine maintenance

If the engine stops for a long time (for several weeks), the following protective measures must be taken so as to prevent it from corrosion damage:

Operating order:

1. Rinse the exterior of diesel engine.
2. Drain off the oil inside the engine and the fuel in injection pump.
3. Add corrosion preventive to the engine.
4. Drain off fuel.
5. Mix fuel oil and corrosion preventive on the scale of 9:1.
6. Fill the fuel tank with the mixture above.
7. Drain cooling water.
8. Add emulsifiable corrosion preventive to the cooling water according to the degree of 5%.
9. Add above compound to cooling system, and vent air from the system.
10. Start the engine and run it for 10 minutes.
11. Stop the engine and turn flywheel for several circles to make the combustion chamber sufficiently wet.
12. Drain off cooling water.
13. Smear exposed parts of the engine with corrosion preventive grease.
14. Close the intake manifold and exhaust manifold.
15. Repeat the above operations after three months.

When the engine is demanded to put into service, you should:

1. Drain off corrosion preventive and mixed fuel.
2. Add oil to the engine.
3. Add fuel and coolant, vent air from the fuel system and cooling system.
4. Remove corrosion preventive grease on the exterior parts.
5. Open the ports of intake manifold and exhaust manifold.

6. Trouble shooting:

Failure to start	The engine stops	Insufficient output	Uneven running of the engine	Black smoke exhaust	Insufficient oil pressure	Uneven engine speed	Engine overheat	Cylinder knocking						Cause	Remedy
▲														The battery power is insufficient, connector of wire becomes loose	Check and charge
▲														Governor handle is not in the starting position	Turn the governor handle to the starting position
▲														Stop lever is in the stop position	Loosen the stop lever
▲	▲	▲	▲			▲								Insufficient fuel	Add fuel
▲					▲									Incorrect lub - oil grade	Renew the lub - oil according to requirements
▲	▲	▲	▲	▲			▲	▲						Injector works abnormally	Check the injector, repair or replace it
▲		▲	▲					▲						Incorrect valve clearance	Adjust according to requirements
		▲		▲										Air cleaner is unclean	Clean or replace it
▲		▲		▲										Compression pressure is insufficient	Inspect and adjust
▲		▲		▲		▲								Governor is out of order	Repair
		▲	▲			▲								Fuel filter is unclean	Replace
▲				▲										Over oiling	Drain off unnecessary oil
					▲									Oil filter is unclean	Replace
					▲									Oil pressure regulating valve is open	Check and clean it
							▲							V belt loosened	Tension it according to requirements
							▲							Insufficient cooling water	Add cooling water
							▲							Thermostat or water pump works abnormally	Repair or replace
		▲						▲						Engine is too cold	
	▲			▲			▲	▲						Engine overloading	Decrease the load
▲	▲	▲	▲			▲								Valve phase is incorrect or camshaft is assembled improperly	Inspect and repair
▲		▲		▲			▲	▲						Air in the fuel system	Drain off air from the system
		▲		▲										Incorrect fuel supply advance angle	Check and correct the advance angle
		▲		▲										Flow path of air compressor housing and impeller of the turbocharger are unclean	Rinse
		▲		▲										Big resistance in intercooler, low cooling efficiency	Rinse
		▲		▲										Exhaust resistance is too big	Find out the cause and eliminate it
							▲							Faults in turbocharger	Replace the assembly
							▲							Cooling efficiency of freshwater cooler decreases severely	Clean up
					▲									Air sucked into the cooling system	Drain off air from the system and eliminate the suction position
														Oil strainer clogged up, oil suction pipe leaks	Inspect, clean and repair

Appendix 1 : Relationship between crankshaft angle Φ and piston displacement S

S(mm)	Φ ()	S(mm)	Φ ()	S(mm)	Φ ()	S(mm)	Φ ()	S(mm)	Φ ()
0.1	2.90	3.6	17.53	8.1	26.51	12.6	33.34	17.1	39.18
0.15	3.56	3.7	17.77	8.2	26.68	12.7	33.48	17.2	39.31
0.2	4.11	3.8	18.02	8.3	26.84	12.8	33.62	17.3	39.43
0.25	4.59	3.9	18.25	8.4	27.01	12.9	33.76	17.4	39.55
0.3	5.03	4.0	18.49	8.5	27.18	13.0	33.89	17.5	39.67
0.35	5.43	4.1	18.72	8.6	27.34	13.1	34.03	17.6	39.79
0.4	5.81	4.2	18.95	8.7	27.50	13.2	34.16	17.7	39.91
0.45	6.16	4.3	19.18	8.8	27.67	13.3	34.29	17.8	40.03
0.5	6.50	4.4	19.47	8.9	27.83	13.4	34.43	17.9	40.15
0.55	6.81	4.5	19.63	9.0	27.99	13.5	34.57	18.0	40.27
0.6	7.12	4.6	19.85	9.1	28.15	13.6	34.71	18.1	40.39
0.65	7.41	4.7	20.07	9.2	28.31	13.7	34.84	18.2	40.51
0.7	7.69	4.8	20.28	9.3	28.47	13.8	34.97	18.3	40.63
0.75	7.96	4.9	20.5	9.4	28.63	13.9	35.11	18.4	40.75
0.8	8.22	5.0	20.71	9.5	28.78	14.0	35.24	18.5	40.87
0.85	8.48	5.1	20.92	9.6	28.94	14.1	35.38	18.6	40.99
0.9	8.72	5.2	21.13	9.7	29.10	14.2	35.51	18.7	41.11
0.95	8.96	5.3	21.33	9.8	29.25	14.3	35.64	18.8	41.22
1.0	9.20	5.4	21.54	9.9	29.40	14.4	35.77	18.9	41.34
1.05	9.42	5.5	21.74	10.0	29.56	14.5	35.90	19.0	41.45
1.1	9.65	5.6	21.94	10.1	29.71	14.6	36.03	19.1	41.58
1.2	10.07	5.7	22.14	10.2	29.86	14.7	36.16	19.2	41.69
1.3	10.49	5.8	22.34	10.3	30.02	14.8	36.29	19.3	41.81
1.4	10.89	5.9	22.53	10.4	30.17	14.9	36.42	19.4	41.93
1.5	11.27	6.0	22.73	10.5	30.32	15.0	36.55	19.5	42.04
1.6	11.64	6.1	22.92	10.6	30.47	15.1	36.68	19.6	42.16
1.7	12.00	6.2	23.11	10.7	30.62	15.2	36.80	19.7	42.28
1.8	12.36	6.3	23.30	10.8	30.76	15.3	36.93	19.8	42.39
1.9	12.70	6.4	23.49	10.9	30.91	15.4	37.06	19.9	42.51
2.0	13.03	6.5	23.68	11.0	31.06	15.5	37.19	20.0	42.62
2.1	13.35	6.6	23.86	11.1	31.21	15.6	37.32	20.1	42.74
2.2	13.67	6.7	24.05	11.2	31.35	15.7	37.44	20.2	42.85
2.3	13.98	6.8	24.23	11.3	31.50	15.8	37.57	20.3	42.97
2.4	14.28	6.9	24.41	11.4	31.64	15.9	37.69	20.4	43.08
2.5	14.58	7.0	24.59	11.5	31.79	16.0	37.82	20.5	43.20
2.6	14.87	7.1	24.77	11.6	31.93	16.1	37.94	20.6	43.31
2.7	15.16	7.2	24.95	11.7	32.07	16.2	38.07	20.7	43.42
2.8	15.44	7.3	25.13	11.8	32.22	16.3	38.19	20.8	43.54
2.9	15.71	7.4	25.30	11.9	32.36	16.4	38.32	20.9	43.65
3.0	15.98	7.5	25.48	12.0	32.50	16.5	38.44	21.0	43.77
3.1	16.25	7.6	25.65	12.1	32.64	16.6	38.57	21.1	43.88
3.2	16.51	7.7	25.83	12.2	32.78	16.7	38.70	21.2	43.99
3.3	16.77	7.8	26.00	12.3	32.92	16.8	38.82	21.3	44.10
3.4	17.03	7.9	26.17	12.4	33.06	16.9	38.94	21.4	44.21
3.5	17.28	8.0	26.34	12.5	33.20	17.0	39.06	21.5	44.33

Appendix 2: Wear Limits of Parts of the Engine

No.	Part name & measuring point	Dimension(mm)		
		Original state		Max. wear limit
		Max.	Min.	
1	Crankshaft Dia. of main journal Dia. of conrod journal Length of thrust main journal Axial clearance measured after mounting	69.97 62.97 36.05	69.951 62.951 36.00	69.93 62.93 36.07 0.4
2	Main bearing			All the two bearings must be replaced if the plated trimetal layer or quad alloy layer is worn down
3	Conrod bearing			
4	Thick of crankshaft thrust washer	3.47	3.42	
5	Dia. of conrod small end bushing	35.08	35.03	35.15
6	Piston pin External cylindrical surface Outside dia. of piston pin	35.00	34.994	Replace if there is scoring 34.990
7	TD/TBD 226B Piston assembly 1st ring groove(trapezoid) 2nd ring groove 3rd ring groove Piston pin bore Contact surface of piston skirt End clearance of piston ring(all) 1st piston ring (trapezoid ring) Clearance of 2nd piston ring in groove Clearance of 3rd piston ring (oil ring) in groove	2.07 4.06	2.05 4.04	Replace if there is wear 2.11 4.11 Replace if there is evident clearance. Replace if there is vertical scoring 2.00 Replace if there is wear on inclined end face of the ring 0.200. 15
8	D226B Piston assembly 1st ring groove(trapezoid) 2nd ring groove 3rd ring groove Piston pin bore Contact surface for piston skirt End clearance of piston ring(all) 1st piston ring (trapezoid ring) Clearance of 2nd piston ring in groove Clearance of 3rd piston ring (oil ring) in groove	2.06 4.06	2.04 4.04	Replace if there is wear 2.10 4.11 Replace if there is evident clearance. Replace if there is vertical scoring 2.00 Replace if there is wear on inclined end face of the ring 0.20 0.15
9	Cylinder liner Inside diameter Honing surface	105.022	105.00	105.250 Replace if vertical scoring exceeds 0.05

No.	Part name & measuring point	Dimension(mm)		
		Original state		Max. wear limit
		Max.	Min.	
10	D/TD/TBD226B Valve and valve guide	8.970	8.952	8.945
	Dia. of valve stem	9.015	9.000	9.060
	Dia. of valve guide bore			
10	Height between valve bottom face and cylinder head face	1.42	1.03	1.80
11	Rocker seat Dia. of rocker shaft	15.984	15.966	15.950
12	Dia. of rocker bearing bore	16.018	16.000	16.040
13	Camshaft			Replace if there is wear 46.920 7.220 Axial clearance; 0.40
	Intake & exhaust cam face	46.960	46.940	
	Dia. of camshaft journal	7.190	7.10	
	Width of camshaft locating slot			
13	Axial clearance of camshaft after mounting			
14	Dia. of camshaft bearing bore on cylinder block	47.045	46.990	47.060
	Bore with bearing mounted in (gear end)	47.025	47.000	47.050
	Bore without bearing mounted in			
14	Inside dia. of tappet hole on cylinder block	17.518	17.500	17.530
15	Thick of tooth sector for camshaft location	7.005	6.850	6.750
16	Outside dia. of tappet	17.494	17.483	17.475
17	Two stage balance shaft assembly			33.940
	Dia. of balance shaft journal	33.975	33.950	
	Axial clearance of balance shaft assembly after mounting			Axial clearance; 0.50
18	Inside dia. of balance shaft bearing bushing	34.050	34.010	34.080 (after mounting)
19	Thick of balance shaft thrust washer	3.55	3.45	3.35

