

PACKING MACHINE

SEMI-AUTOMATIC STRAPPING MACHINE

INSTRUCTION MANUAL

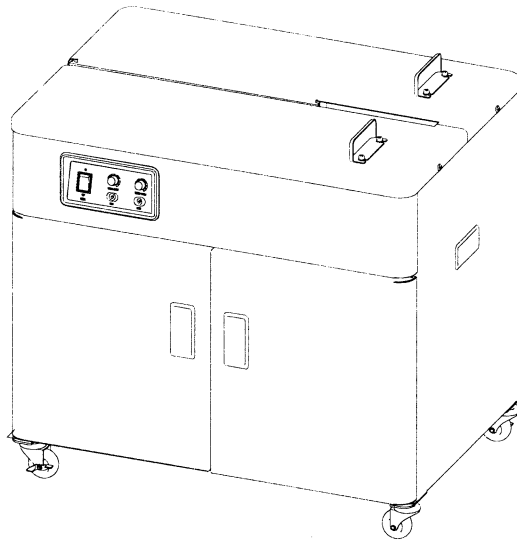

Please read this instruction manual before operation

Contents

1. Safety instruction.....	3
2. Brief introduction.....	4
3. Machine structure drawing.....	5
4. Control panel	5
5. Operation and use of functional key on the electric appliance box.....	6
6. Adjustment of regulation resistance on PCB.....	8
7. Installation of strap coil.....	9
8. Threading method.....	9
9. Width adjustment for different kinds of straps	10
10. Object packing operation	11
11. Heat element-hot knife.....	11
12. Micro-switch on cam assembly& magnet control relay.....	12
13. Printing circuit board—Electron control circuit.....	12
14. Electric motor.....	13
15. Blower.....	13
16. Electric wiring diagram.....	14
17. Electric wiring diagram element list.....	15

1. Safety instruction

1.1 Installation

- (1) The equipment must be installed in dry, airy environment and there should be no thick and conductive stive no acidic gas.
- (2) Suitable working temperature is -10°C ~ $+40^{\circ}\text{C}$. When environmental temperature is lower, inside elements may get ice or dew easily, which will lead to electric shock or electricity leaking accident. Too high environmental temperature may cause malfunction also.
- (3) Keep the power cord away from straps and strap coil. Or the skin of the power cord will be abraded and may cause an electric shock.

1.2 Usage

- (1) Please use power as appointed specification, take grounded three-core power cord and socket.
- (2) Don't open the cover board when the machine is running normally, you may get hurt from an accidental touch to the driving parts.
- (3) Don't touch up& down slide plate、hot knife bracket and other driven parts of a running machine, they may scald or clamp you.
- (4) To avoid scald, please don't touch hot knife and around accessories.
- (5) When the equipment stops running, don't touch and tear down hot knife bracket and around heat conducting objects in a short time, please wait until they are cool, or you may be scalded.
- (6) Please don't put your hands into the running strapping coil, and don't grasp straps by your hands, or you may get hurt by the sharp edge.
- (7) After insert strap into guide slot of a running machine, the strap will be entangled into the machine automatically, then you should move away your hands quickly or you may be clamped.
- (8) Don't insert straps into guide slot when there are no packing objects.

1.3 Repair and Others

- (1) Please unpin power socket and shut off power supply when you repair、examine and clean the machine.
- (2) Please maintain and service the machine regularly.
- (3) Only trained personal can repair and debug the machine.
- (4) Please don't change the machine without leave, or it may present un-contemplated injury and machine damage.

2. Brief instruction

Main application

It's mainly used for packing carton, wooden box, books and squareness, columniform, ring-shaped objects, it is widely used in home appliances, light manufacturing, food, foreign trade, general merchandise, medicine, post, chemical industries, textile and print to seal and pack cartons.

Specification and parameter

Dimension(length×width×height)	775×545×745mm
Machine weight	60kg
Strapping range: minimum	>60mm
maximum	Free size
Sealing way	Heat sealing
Strapping way	Fixed-length
Tension	5-50kgf
Width of strap	5-15mm
voltage	220V±10%
Frequency	50-60HZ
power	250W

Machine dimension

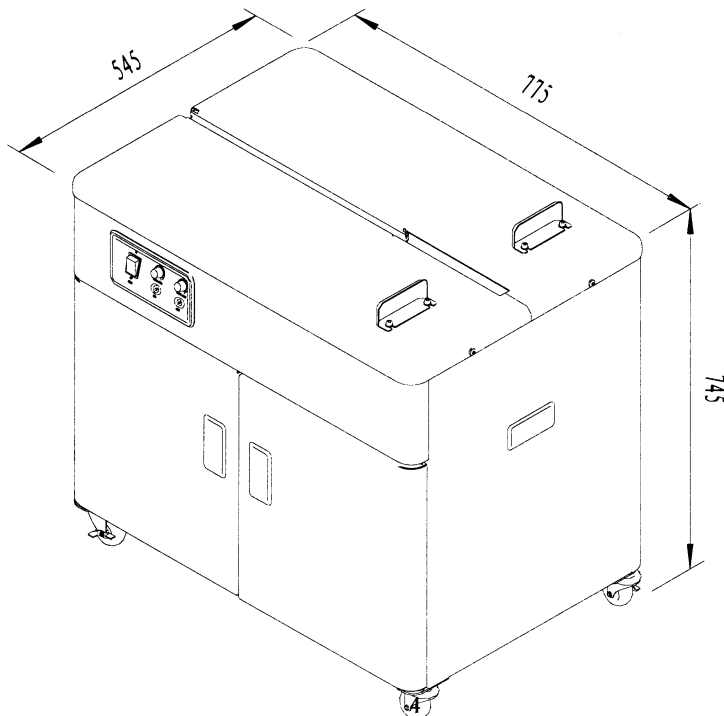

3. Machine structure drawing

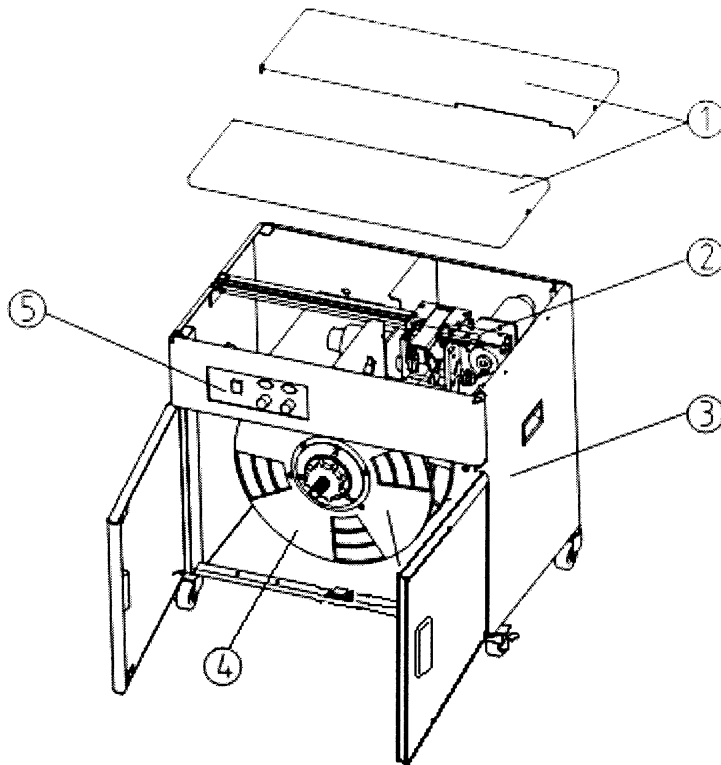

4. Control Panel

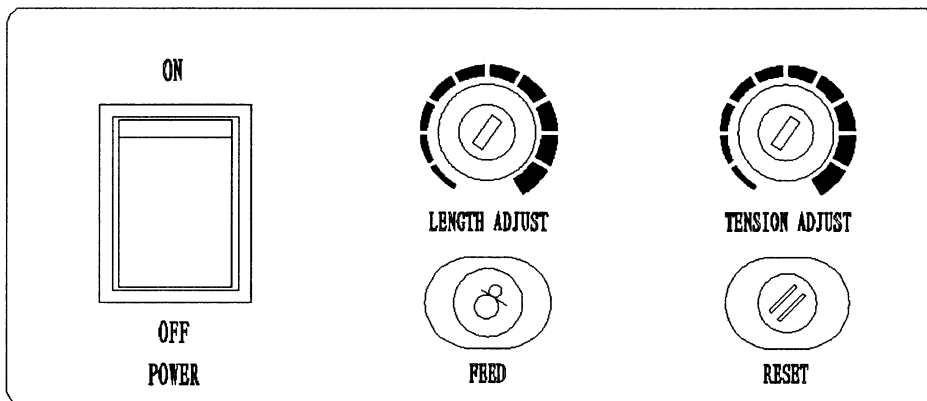

4.1 Power switch

Press "on" or "off", indication lamp will be on when press "on".

4.2 Tension adjusting knob

It is used for adjusting packing tension. Swivel adjusting knob to increase, packing tension increases at same time; Contrarily when scale value decreases, packing tension also

decreases.

4.3 Strap length adjusting knob

It is used for setting the length of straps according to the size of the packing objects, swivel adjusting knob, scale value increases, and feeding strap becomes longer, on the other hand, scale value decreases, feeding strap becomes shorter.

4.4 Return to zero button

Return to zero means the state of last packing cycle is finished and next packing cycle begins. Packing movement will return to zero state when press down return to zero button before last packing cycle finished. If packing task is at zero state and press down return to zero button, packing task will return to zero state after one packing cycle. With the second press, system will perform reversing movement.

4.5 Feeding button

Feeding button is designed for adjusting strap's feeding length. The longer time you press, the longer strap will be sent, vice versa.

For strap installment: sent strap into the machine, reach a ready-state.

For a larger package: initially length-setting are short, press feeding button for enough strap.

5. Operation and use of function key on the electric appliance box

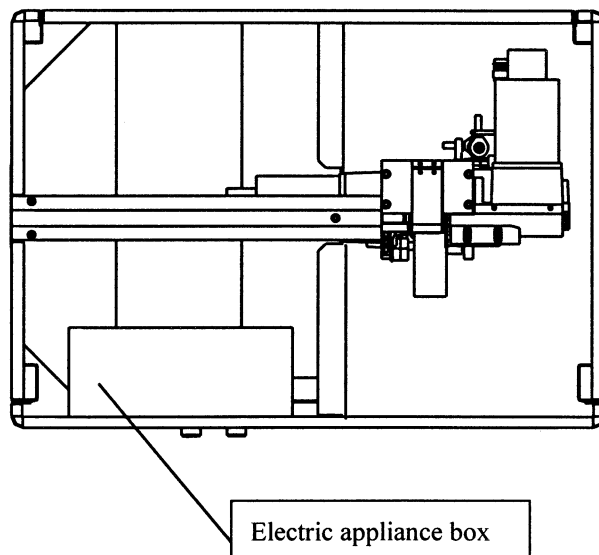

Location of the electric appliance box

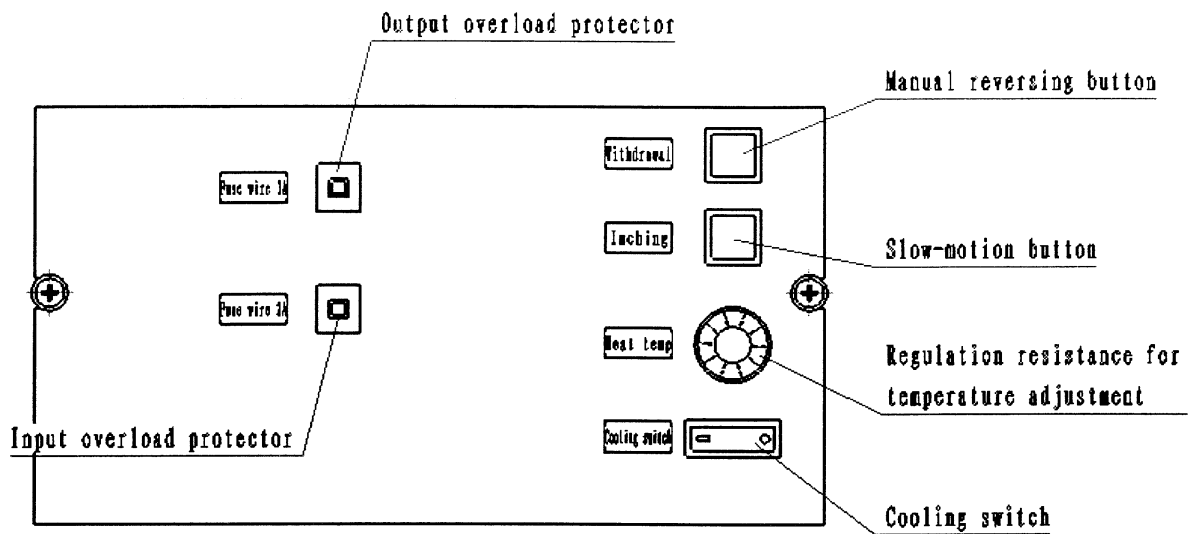

Keys on the cover of electric appliance box

5.1 Cooling Switch

Cooling switch of “I” and “O” controls the power to “cooling time adjusting regulation resistance” on PCB for cooling time adjustment. Switch to “I” when set or adjusting cooling time, and shift to “O” when finished.

NOTE:

a. Cooling switch and “cooling time adjusting regulation resistance” on PCB could be combined in use. Cooling switch must be shut off (switch to “O”) when adjust regulation resistance, or it will damage electric elements on PCB.

b. Simple use

Switch to “I”: means relative longer cooling time, consider to choose when use thick strap or a big tension. In other situation, just choose “O” is suggested.

5.2 Temperature regulation resistance

It is used for adjusting hot knife’s temperature, swivel adjusting knob. The bigger scale value, the higher hot knife’s temperature will be, conversely, when scale value is smaller, hot knife’s temperature is lower.

Hot knife’s temperature had been debugged when machine left factory. Some strap leavings will be adsorbed on hot knife’s working area which will accumulate during a long time use and may lead to a lower temperature problem. And regulation resistance may failed to rise enough temperature for strapping, then you should you shut off power, pluck off socket, do await hot knife completely cooled, and use a knife edge to clear off strap leavings on hot knife, restore regulation resistance lastly.

5.3 Slow-motion button

Press down this button, driven electromotor will carry on step by step for an easy observation of

cam assembly's working condition.

5.4 Manual reversing button

Drive double shaft electromotor reverse to withdraw straps in the system step by step. Longer-press for more strap reversed, contrarily, less strap reserved. This button can adjust the length of straps in system and observe the functional mode of reversing system.

5.5 Output overloaded protector (3A)

It is on the top left side of control box , squareness, black. This overloaded protector is used for transformer's output overload protection. Switch off power when overloading, after fault remedy, press down the raised red part in the middle to restore and electric circuit will resume to connecting state again.

5.6 Input overloaded protector (3A)

It is on the down left side of control box cover, squareness, black. This overload protector is machine's power input overload protection, switch off power when overloaded, after fault remedy, press down the raised red part in the middle to restore and electric circuit will resume to connecting state again.

6. Adjusting regulation resistance on PCB

Cooling time adjusting regulation resistance-----it locates at the middle bottom of PCB, marked

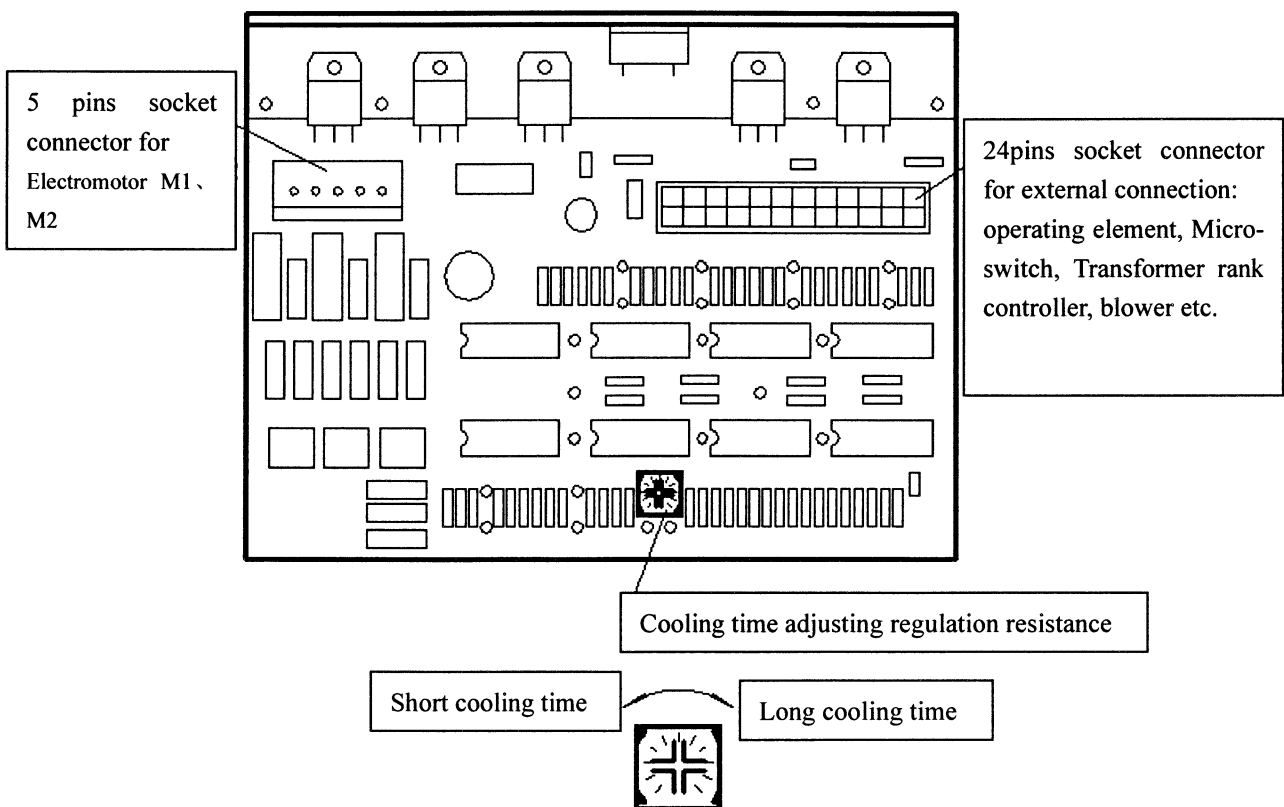

“504” (resistance value:500k), light blue, squareness.

Activation & Operation:

Will be active after Switched off the power and turned off (switch to “0” here) the cooling switch on the right side of control box; Under active state, adjust this regulation resistance to adjust cooling time, when cooling time is adjusted long ,the whole packing cycle will also be long, and the packing speed will slow down.

Function:

When hot knife withdraws from knife bracket and welding gripper presses the just heated strap for a while and cool off for a moment to make strap bond firmly. Adjust the cooling time of regulation resistance on PCB, means adjusting cooling time to improve strap’s bonding quality.

7. Installation of strap coil

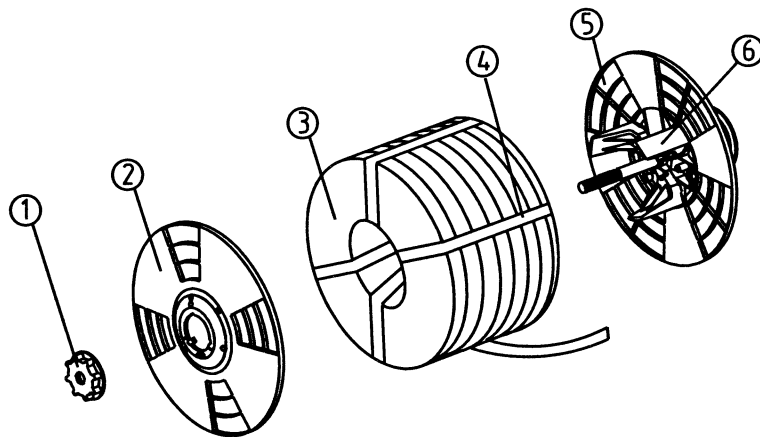

- (1) Turn right (clockwise) the coil fasten knob ① and take it off, then take the left flange ② off also.
- (2) Strap end of the strap coil ③ directs left (anti-clockwise), then insert coil into the centre guide (3 feet) ④ of the right flange ⑤.
- (3) Restore left flange ② to clamp strapping tape coil, turn left (anti-clockwise) the knob ① to fasten it.
- (4) At last, cut off the strapping belt ④ which used for fasten strapping bands.

8. Threading method

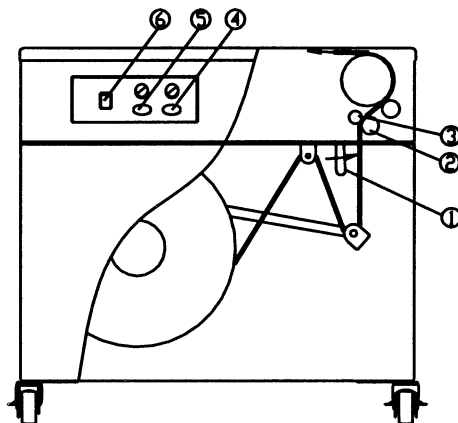

- (1)The power switch⑥ on control board is in “on” state.
- (2)Press reset switch ④ on control board, machine returns home position then stops automatically.
- (3)Pull lever①, insert strapping bands between roller② and roller③ as the chart shows.
- (4) Leave lever①, take your hands away from strapping bands.
- (5) Press down the feeding button⑤ on control board until there is enough strapping band in the guide slot.

9.Width adjustment for different kinds of straps

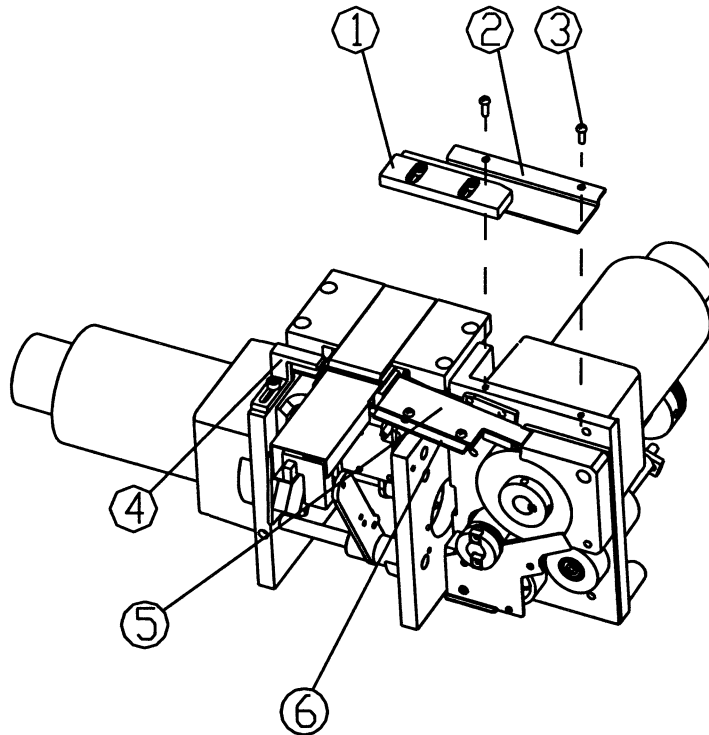

When strapping bands are of different width, it needs some adjustments.

- (1)Loose off screw③, take out accessories① and ②.
- (2)Loose screw between accessories ⑤ and ⑥, remove ⑥ to make the width of the slot 0.5mm-1mm wider than strapping band, then fix screw.
- (3)Loose screw between accessories ① and ②, remove ① to make the width of the slot 0.5mm-1mm wider than strapping band, then fix screw.
- (4)Tighten screw③, fix accessories① and② on the main body.
- (5)Loose accessory④ then remove it, make the width of the slot is 0.5mm-1mm wider than strapping band, then fix screw.

10. Packing Operation

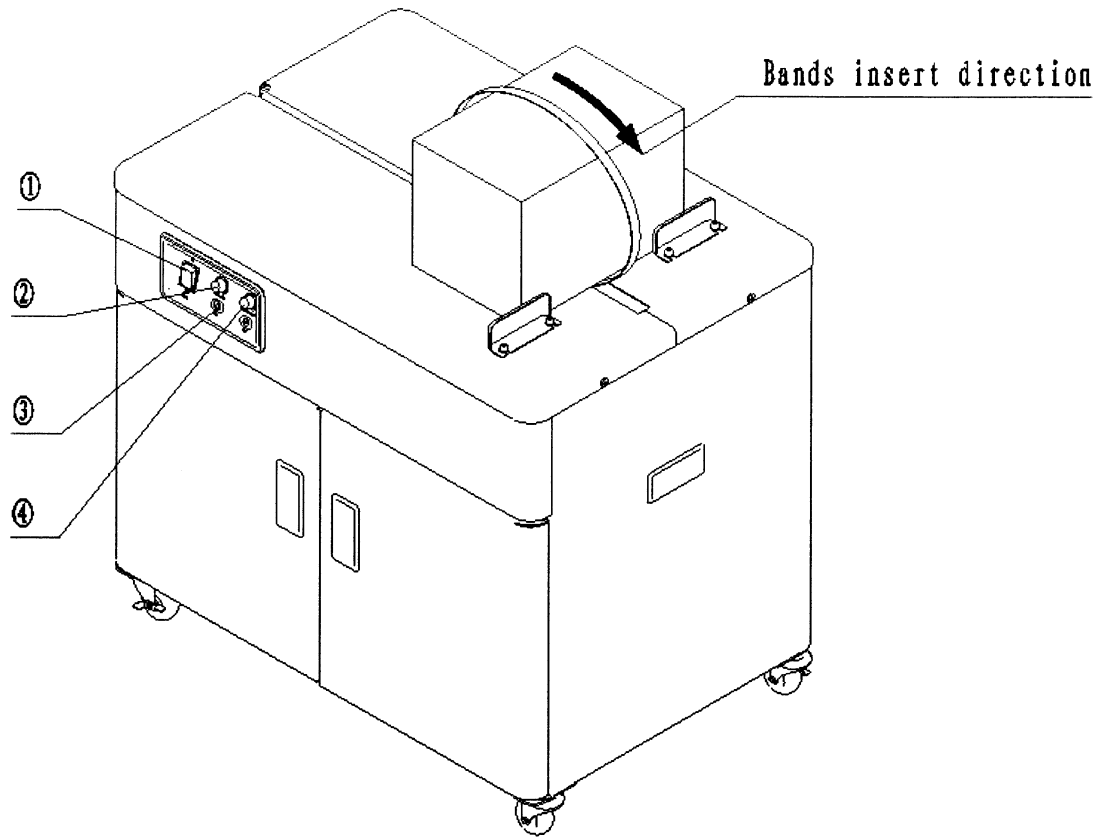

- (1) Turn on power switch, hot knife will reach to proper temperature for use in about 30 seconds.
- (2) Adjust tension button to set proper tension, in order to avoid object damage, first set to small tension, then adjust it after first packing cycle.
- (3) Put the packing objects on the machine, hold the end of the strapping band and insert it into the guide slot through the right guide way, (if the band isn't enough press the feeding switch ③ to replenish), machine starts packing then will release band automatically as set after packing circle.
- (4) Adjust length adjust knob ② to set the length of strapping band for packing objects. Trial-Pack several times to set a proper length. Always the set length should be about 200mm longer than the girth of the packing objects.

11. Heat element---hot knife

(1) Structure of hot knife

Hot knife is made up of excellent electrothermal material wrapping on the heating element、 mica insulation board, stainless cover. The stainless cover, firm structure has the function of increasing heat、 affording stable heat、 decreasing temperature fluctuation. There is mica insulation board between galvanic heating board and stainless cover with good insulating property and safety.

(2) Character of heat adjusting

Heat element with stable low current closed-loop controlled affords stable 、adjustable and

safe heat. When welding strap, hot knife insert into the heating area of knife bracket with high power; while after welding, hot knife withdraws from heating area with low power, which will save power and prolong heat head's service life.

(3) Straight line's translation movement

Heating head's straight translation movement improves its heating efficiency.

12. Micro-switch on cam assembly and magnet control relay

Micro-switch LS1、LS2、LS4 and magnet control relay LS3 are pressed by the running cam assembly in sequence during packing process, these switches on and off to control the whole packing process orderly.

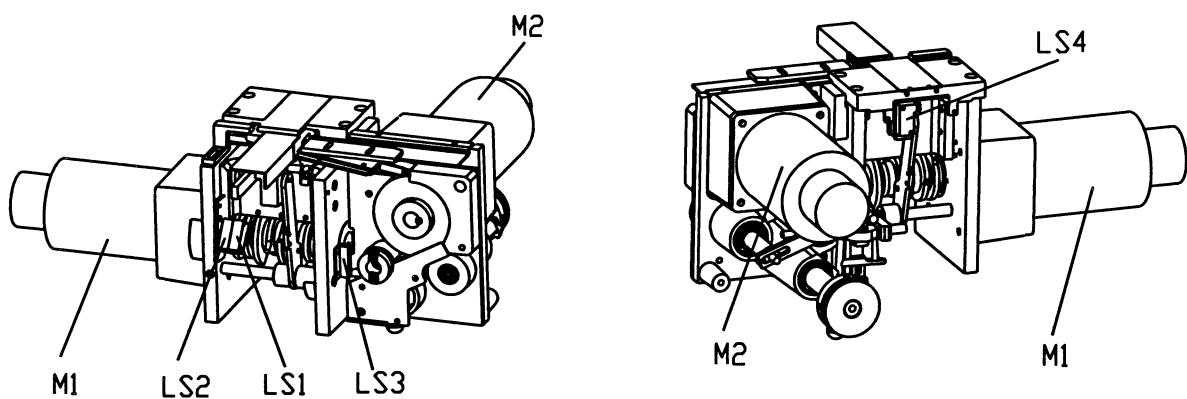

LS1 (original point switch):

It is used for detecting the original point of cam axle on body unit.

LS2 (time switch):

It is used for detecting reversing tension time during packing cycle.

LS3 (magnet control relay):

It is used for detecting if strapping band has strapped package.

LS4 (start switch):

Make strapping band's head round package and press this micro-switch, then machine will be started and begin a packing cycle.

13. Print circuit board(PCB)—Electron controls circuit

(1)Control circuit adopts integrated package to make up logic circuit, uses both-way controllable silicon as switch to control electromotor start and stop, adopts non-contact control method to control electromotor run and stop, reliable;

(2)Use optical coupler to separate control unit and output unit, safe and high anti-jamming;

(3)PCB uses two socket connectors to connect machine's operating switch、micro-switch and two electro-motors separately, and intense current and feeble current are separated also, safety and convenience;

(4)Control power and heating power share the same one 45VA control transformer, energy saving and simple.

14. Motor

Machine has been installed two single phase motors, each motor outputs after slowdown through gear box, compact construction, low noise, high efficiency.

M1: this motor is used for driving cam assembly, single head out of axle, power is single-phase alternating current, 220V/50Hz, unidirectional rotation.

M2: this motor is used for feeding driven setup, two heads out of axle, power is single-phase alternating current, 220V/50Hz, it can run positive and opposite direction, when it runs positive direction to feed and opposite direction to reverse.

15. Fan

This Fan is set to expulse discharge waste gas. The Fan is 60mm (length)*60(width)mm with +12V direct current from PCB. Little power consumption, low noise, strong air discharge.

16. Electric wiring diagram

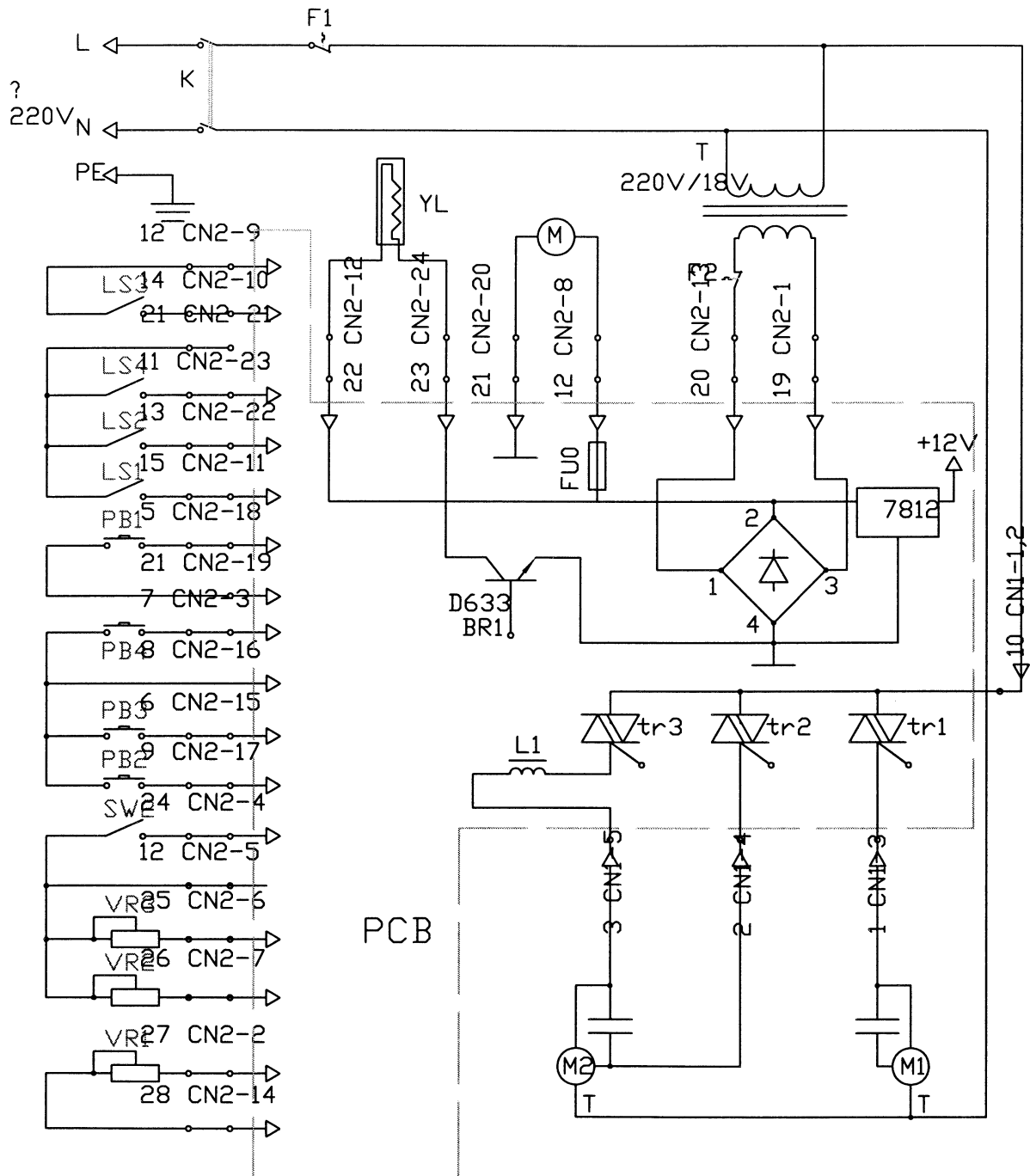

17. Electric wiring diagram element list

Code Name	Item of elements	Code Name	Item of elements
K	Power Switch	LS3	Magnet Control Relay
F1	3A Input Overloaded Protector	PCB	Print Circuit Board
F2	3A Output Overloaded Protector	CN1	5Pins Socket Connector
T	Transformer 45VA 200V/18V	CN2	24pins Socket Connector
PB1	Restore Button	M	Blower
PB2	Manual Feeding Button	M1	Single Phase Motor (Driven Cam)
PB3	Manual Reverse Button	M2	Single Phase Motor (Driven Cam)
PB4	Slow-motion Button for driven cam motor	YL	Hot Knife (Heating Element)
SW	Cooling time Switch	VR1	Temperature regulation resistance
LS1	Micro-switch	VR2	Tension regulation resistance
LS2	Micro-switch	VR3	Tension regulation resistance
LS4	Micro-switch		