



# Y80 DIESEL ENGINE PARTS CATALOGUE

**YANGDONG CO., LTD.**  
**THE PEOPLE'S REPUBLIC OF CHINA**

# 目 录

## CONTENTS

1.机体总成 (480)	Engine Body Assy (480)	.....	(1)
2.机体总成 (380)	Engine Body Assy (380)	.....	(6)
3.机体总成 (280)	Engine Body Assy (280)	.....	(11)
4.正时齿轮室总成 (480, 380, 280)	Timing Gear Case Assy (480, 380, 280)	.....	(16)
5.气缸盖总成 (480, 380, 280) I	Cylinder Head Assy (480, 380,280) I	.....	(19)
6.气缸盖总成 (480, 380, 280) II(带减压装置)	Cylinder Head Assy (480, 380, 280) II (with Pressure-reducing Device)	.....	(23)
7.活塞连杆总成 (480, 380, 280)	Piston-connecting Rod Assy (480, 380, 280)	.....	(28)
8.曲轴飞轮总成 (480, 380, 280)	Crankshaft-flywheel Assy (480, 380, 280)	.....	(30)
9.凸轮轴总成 (480, 380, 280)	Camshaft Assy (480, 380, 280)	.....	(32)
10.进气管总成 (480, 380, 280)	Intake Pipe Assy (480, 380, 280)	.....	(34)
11.排气管总成 (480, 380, 280)	Exhaust Pipe Assy (480, 380, 280)	.....	(36)
12.润滑系统总成 (480, 380, 280)	Lubricating System Assy (480, 380, 280)	.....	(38)
13.燃油系统总成 (480, 380, 280)	Fuel System Assy (480, 380, 280)	.....	(41)
14.冷却系统总成 (480, 380, 280)	Cooling System Assy (480, 380, 280)	.....	(43)
15.电气系统总成 (480, 380, 280)	Electric System Assy (480, 380, 280)	.....	(46)
16.消声器总成 (480, 380, 280)	Silencer Assy (480, 380, 280)	.....	(48)
17.随机工具总成 (480, 380, 280)	Tools Supplied with the Engine (480, 380, 280)	.....	(50)

# 1. 机体总成 (480) Engine Body Assy (480)

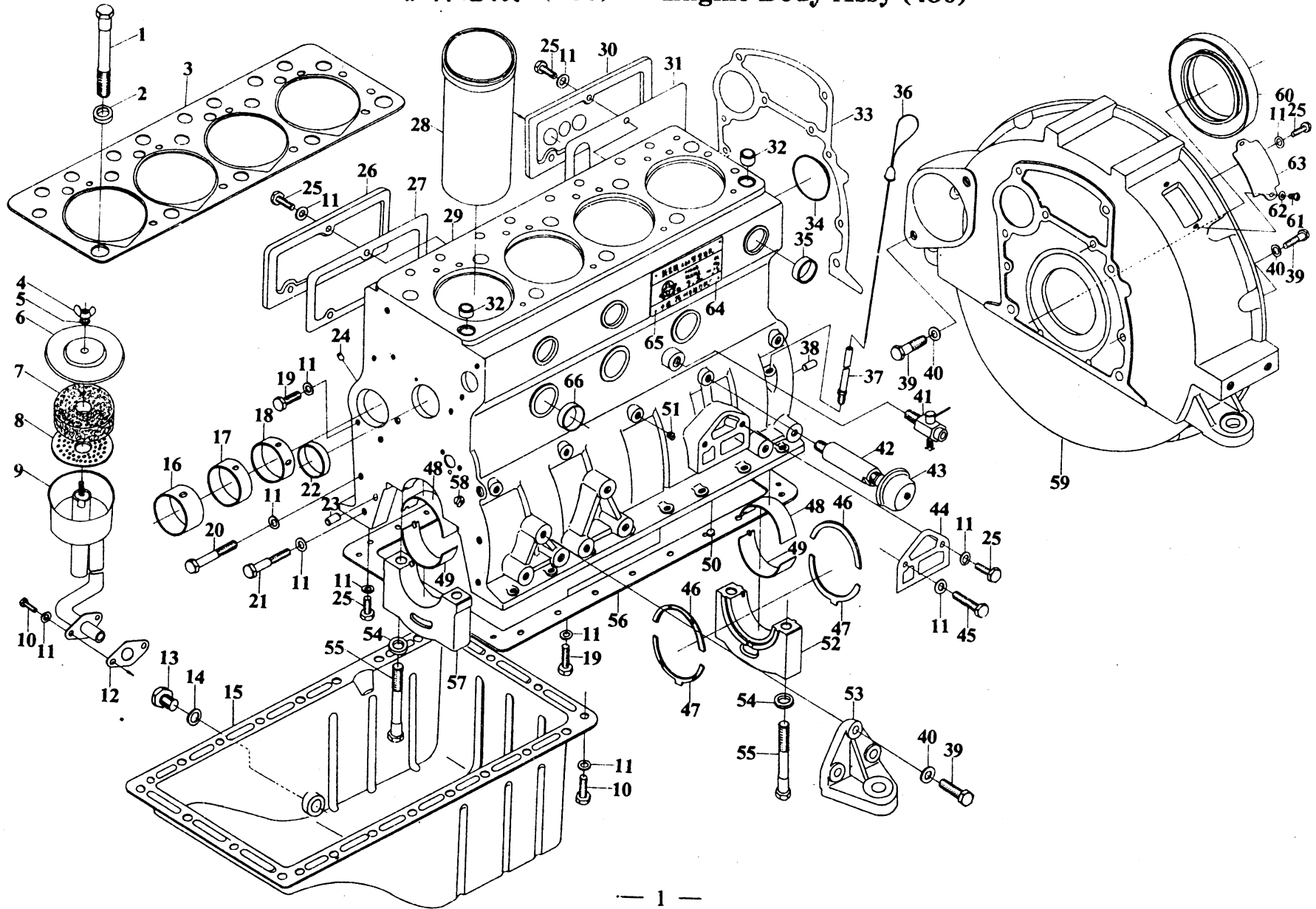

### 1. 机体总成 (480)    Engine Body Assy (480)

序 号 Ser No	图 号 Parts No	名 称 Name of Parts	数 量 Qty	附 注 Remarks
1	480G-01005	缸盖螺栓	10	
2	480G-01006	缸盖螺栓垫圈	10	
3	480G-01002	气缸盖垫片	1	
4	GB62-88	蝶形螺母 M6	1	
5	GB848-85	垫圈 6-140HV	1	
6	480G-01201	呼吸器盖	1	
7	480G-01203	滤网	1	
8	480G-01202	呼吸器隔板	1	
9	480G-01210	呼吸器焊接件	1	
10	GB5783-86	螺栓 M8 × 16	24	
11	GB848-85	垫圈 8-140HV	54	
12	480G-01011	呼吸器垫片	1	
13	480G-01703	放油螺塞	1	
14	480G-01704	垫圈	1	
15	480G-01701	油底壳	1	焊合件 Weldment
16	480G-01024	凸轮轴前衬套	1	
17	480G-01025	凸轮轴中衬套	1	
18	480G-01026	凸轮轴后衬套	1	
19	GB5783-86	螺栓 M8 × 20	7	
20	GB5782-86	螺栓 M8 × 60	8	

序号 Ser No	图号 Parts No	名称	Name of Parts	数量 Qty	附注 Remarks
21	GB5782-86	螺栓 M8×55	Bolt M8×55	4	
22	480G-01109	碗形塞片	Bowl-shaped plug piece	2	
23	GB119-86	销 B8×20	Pin B8×20	1	
24	480G-01108	堵塞	Stopper	3	
25	GB5783-86	螺栓 M8×25	Bolt M8×25	10	
26	480G-01013	侧盖 (II)	Side cover (II)	1	
27	480G-01014	侧盖(II)垫片	Side cover (II) spacer	1	
28	480G-01003	气缸套	Cylinder sleeve	4	
29	480G-01111	机体	Engine body	1	
30	480G-01012	侧盖 (I)	Side cover (I)	1	
31	480G-01023	侧盖 (I) 垫片	Side cover (I) gasket	1	
32	480G-01102	定位套	Locating sleeve	2	
33	480G-01009	飞轮壳垫片	Flywheel housing gasket	1	
34	480G-01101	塞片	Plug piece	1	
35	480G-01103	碗形塞片	Bowl-shaped plug piece	4	
36	480G-01400	机油尺部件	Oil level dipstick	1	
37	480G-01600	油尺套管焊接部件	Dipstick sleeve weldment	1	
38	GB119-86	销 B10×20	Pin B10×20	2	
39	GB5783-86	螺栓 M10×30	Bolt M10×30	14	
40	GB848-85	垫圈 10-140HV	Washer 10-140HV	14	

序号 Ser No	图号 Parts No	名称	Name of Parts	数量 Qty	附注 Remarks
41	480G-01300	放水开关部件	Water drain cock	1	
42	480G-01021	机油压力传感器接管	Connecting pipe for oil pressure sensor	1	
43	480G-01500	压力表用传感器部件	Sensor for oil gauge	1	
44	480G-01004	机油滤清器垫片	Oil filter gasket	1	
45	GB5782-86	螺栓 M8×45	Bolt M8×45	1	
46	480G-01007	曲轴止推片(上)	Upper thrust piece of crankshaft	2	
47	480G-01008	曲轴止推片(下)	Lower thrust piece of crankshaft	2	
48	480G-01015	主轴瓦上瓦	Main bearing halfshell (upper)	5	
49	480G-01016	主轴瓦下瓦	Main bearing halfshell (lower)	5	
50	480G-01107	碗形塞片	Bowl-shaped plug piece	1	
51	480G-01106	Z 1/8" 圆锥螺塞	Z 1/8" taper plug	4	
52	480G-01113	后主轴承盖	Rear main bearing cap	1	
53	480G-01017	支承脚	Stand bar	2	
54	480G-01114	主轴承螺栓垫圈	Main bearing bolt washer	10	
55	480G-01115	主轴承盖螺栓	Main bearing cap bolt	10	
56	480G-01018	油底壳垫片	Oil sump gasket	1	
57	480G-01112	主轴承盖	Main bearing cap	4	
58	480G-01105	Z 1/4" 圆锥螺塞	Z 1/4" taper plug	2	
59	480G-01010	飞轮壳	Flywheel housing	1	

序号 Ser No	图号 Parts No	名称	Name of Parts	数量 Qty	附注 Remarks
60	HG4-692-67	骨架式橡胶油封 PG80×100×12	Cased rubber oil seal PG80×100×12	1	
61	GB67-85	螺钉 M6×12	Screw M6×12	2	
62	GB97.1-85	垫圈 6-140HV	Washer 6-140HV	2	
63	480G-01019	盖板	Cover plate	1	
64	480G-01020	标牌	Name plate	1	
65	GB827-86	铆钉 2×5	Rivet 2×5	4	
66	480G-01104	碗形塞片	Bowl-shaped plug piece	8	

## 2. 机体总成 (380) Engine Body Assy (380)

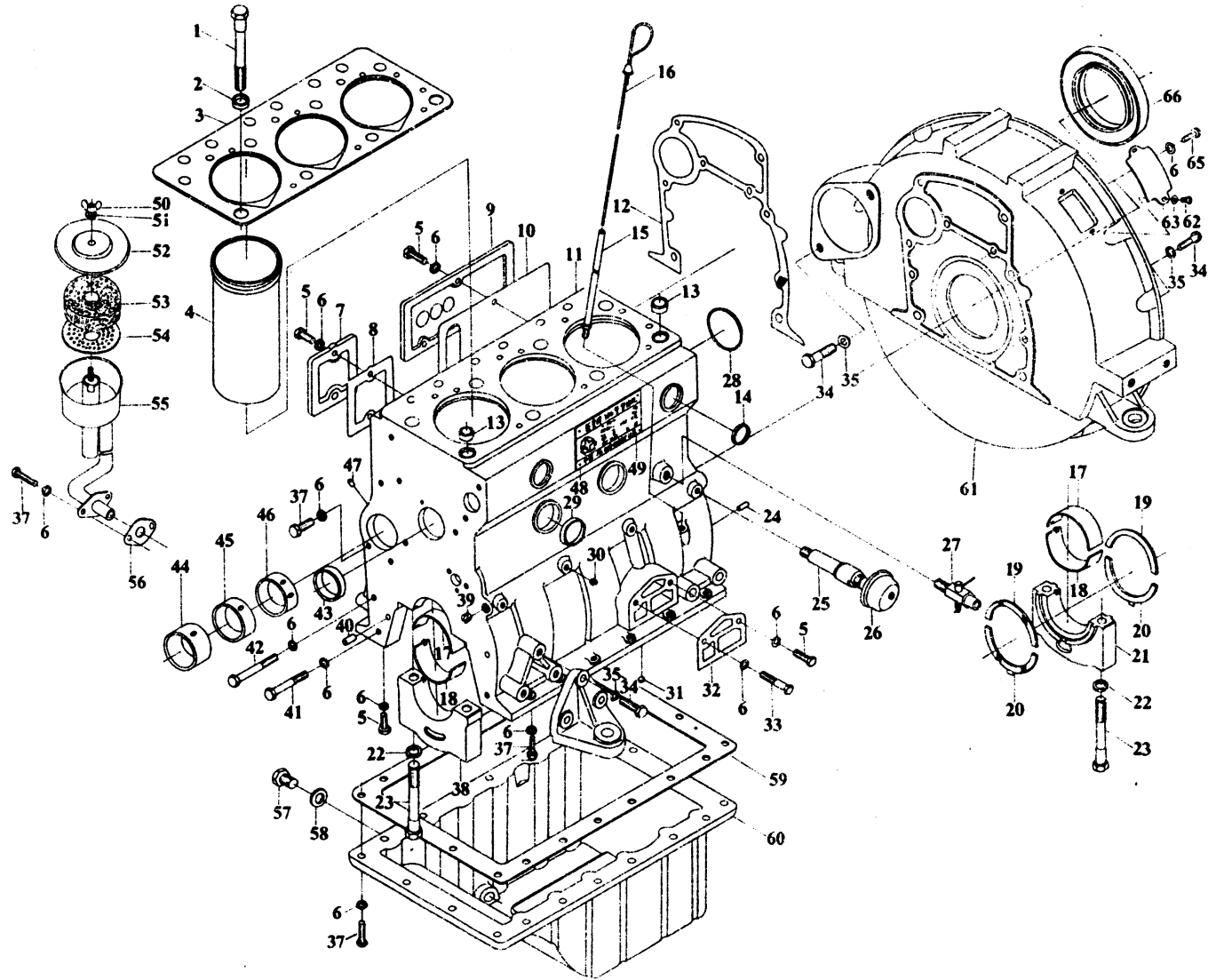



## 2. 机体总成 (380)      Engine Body Assy (380)

序 号 Ser No	图 号 Parts No	名 称 Name of Parts	数 量 Qty	附 注 Remarks
1	480G-01005	缸盖螺栓	8	
2	480G-01006	缸盖螺栓垫圈	8	
3	380-01002	气缸盖垫片	1	
4	480G-01003	气缸套	3	
5	GB5783-86	螺栓 M8×25	6	
6	GB848-85	垫圈 8-140HV	49	
7	380-01013	侧盖 (II)	1	
8	380-01014	侧盖 (II) 垫片	1	
9	480G-01012	侧盖 (I)	1	
10	480G-01023	侧盖 (I) 垫片	1	
11	380-01111	机体	1	
12	480G-01009	飞轮壳垫片	1	
13	480G-01102	定位套	2	
14	480G-01103	碗形塞片	3	
15	480G-01600	油尺套管焊接部件	1	
16	480G-01400	机油尺部件	1	
17	480G-01015	主轴瓦上瓦	4	
18	480G-01016	主轴瓦下瓦	4	
19	480G-01007	曲轴止推片 (上)	2	
20	480G-01008	曲轴止推片 (下)	2	

序号 Ser No	图号 Parts No	名称	Name of Parts	数量 Qty	附注 Remarks
21	480G-01113	后主轴承盖	Rear main bearing cap	1	
22	480G-01114	主轴承螺栓垫圈	Main bearing bolt washer	8	
23	480G-01115	主轴承盖螺栓	Main bearing cap bolt	8	
24	GB119-86	销 B10×20	Pin B10×20	2	
25	380-01021	机油压力传感器接管	Connecting pipe for oil pressure sensor	1	
26	480G-01500	压力表用传感器部件	Sensor for oil gauge	1	
27	480G-01300	放水开关部件	Water drain cock	1	
28	480G-01101	塞片	Plug piece	1	
29	480G-01104	碗形塞片	Bowl-shaped plug piece	6	
30	480G-01106	Z 1/8" 圆锥螺塞	Z 1/8" taper plug	3	
31	480G-01107	碗形塞片	Bowl-shaped plug piece	1	
32	480G-01004	机油滤清器垫片	Oil filter gasket	1	
33	GB5782-86	螺栓 M8×45	Bolt M8×45	1	
34	GB5783-86	螺栓 M10×30	Bolt M10×30	14	
35	GB848-85	垫圈 10-140HV	Washer 10-140HV	14	
36	480G-01017	支承脚	Stand bar	2	
37	GB5783-86	螺栓 M8×20	Bolt M8×20	29	
38	480G-01112	主轴承盖	Main bearing cap	3	
39	480G-01105	Z 1/4" 圆锥螺塞	Z 1/4" taper plug	2	
40	GB119-86	销 B8×20	Pin B8×20	1	

序号 Ser No	图号 Parts No	名称 Name of Parts	数量 Qty	附注 Remarks	
41	GB5782-86	螺栓 M8×55	Bolt M8×55	4	
42	GB5782-86	螺栓 M8×60	Bolt M8×60	8	
43	480G-01109	碗形塞片	Bowl-shaped plug piece	2	
44	480G-01024	凸轮轴前衬套	Front camshaft bush	1	
45	480G-01025	凸轮轴中衬套	Middle camshaft bush	1	
46	480G-01026	凸轮轴后衬套	Rear camshaft bush	1	
47	480G-01108	堵塞	Stopper	3	
48	GB827-86	铆钉 2×5	Rivet 2×5	4	
49	380-01020	标牌	Name plate	1	
50	GB62-88	蝶形螺母 M6	Butterfly nut M6	1	
51	GB848-85	垫圈 6-140HV	Washer 6-140HV	1	
52	480G-01201	呼吸器盖	Respirator cover	1	
53	480G-01203	滤网	Filter gauze	1	
54	480G-01202	呼吸器隔板	Respirator partition	1	
55	480G-01210	呼吸器焊接件	Respirator weldment	1	
56	480G-01011	呼吸器垫片	Respirator gasket	1	
57	480G-01703	放油螺塞	Oil drain plug	1	
58	480G-01704	垫圈	Washer	1	
59	380-01018	油底壳垫片	Oil sump gasket	1	
60	380-01701	油底壳	Oil sump	1	

序号 Ser No	图号 Parts No	名称 Name of Parts	数量 Qty	附注 Remarks
61	480G-01010	飞轮壳 Flywheel housing	1	
62	GB67-85	螺钉 M6×12 Screw M6×12	2	
63	GB97.1-85	垫圈 6-140HV Washer 6-140HV	2	
64	480G-01019	盖板 Cover plate	1	
65	GB5783-86	螺栓 M8×30 Bolt M8×30	2	
66	HG4-692-67	骨架式橡胶油封 PG80×100×12 Cased rubber oil seal PG80×100×12	1	

### 3.机体总成 (280) Engine Body Assy (280)

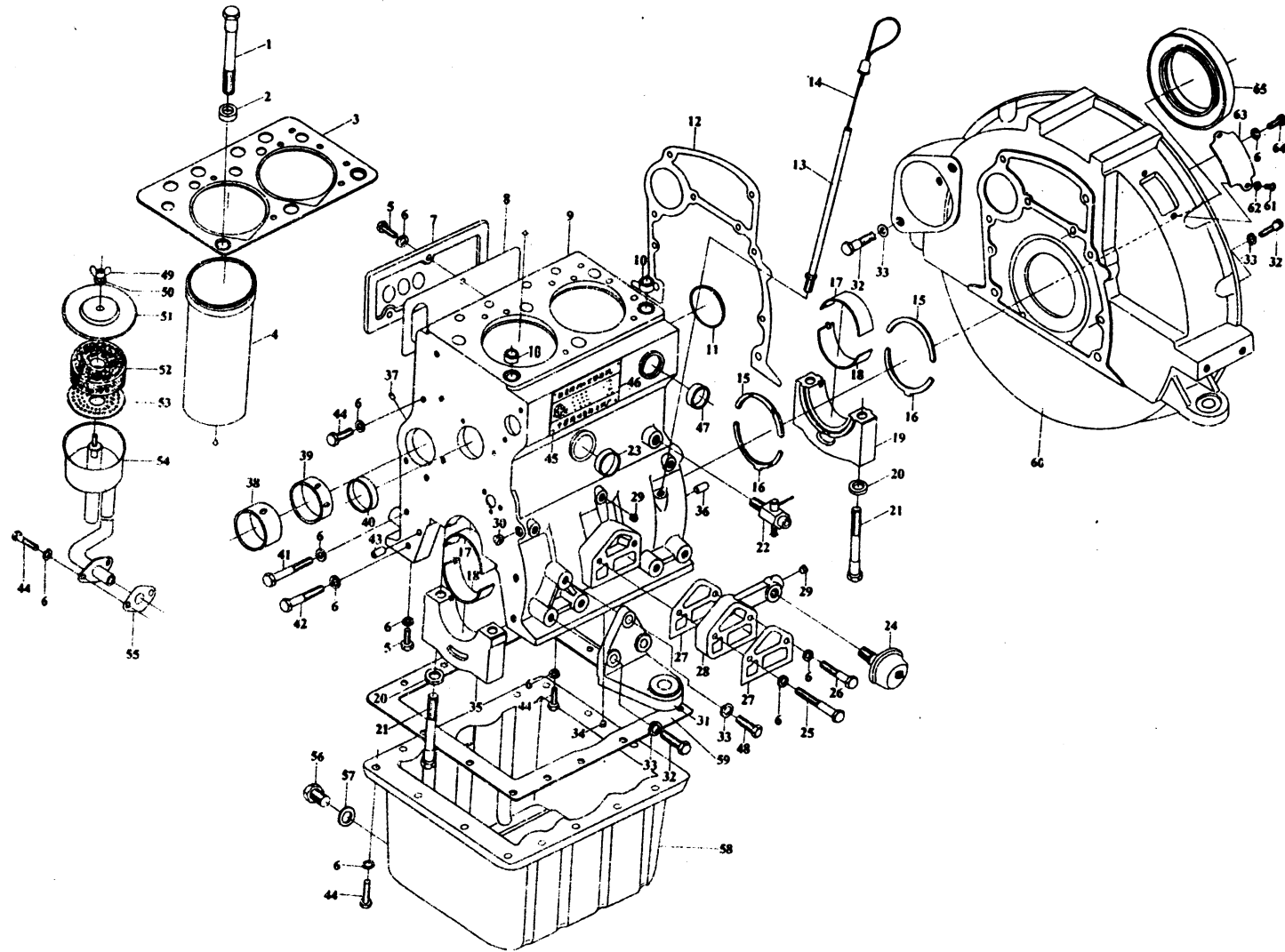

### 3.机体总成 (280)    Engine Body Assy (280)

序号 Ser No	图号 Parts No	名称	Name of Parts	数量 Qty	附注 Remarks
1	480G-01005	缸盖螺栓	Cylinder head bolt	6	
2	480G-01006	缸盖螺栓垫圈	Cylinder head bolt washer	6	
3	280-01002	气缸盖垫片	Cylinder head gasket	1	
4	480G-01003	气缸套	Cylinder sleeve	2	
5	GB5783-86	螺栓 M8×25	Bolt M8×25	4	
6	GB848-85	垫圈 8-140HV	Washer 8-140HV	43	
7	480G-01012	侧盖 (I)	Side cover (I)	1	
8	480G-01023	侧盖 (I) 垫片	Side cover (I) gasket	1	
9	280-01111	机体	Engine body	1	
10	480G-01102	定位套	Locating sleeve	2	
11	480G-01101	塞片	Plug piece	1	
12	480G-01009	飞轮壳垫片	Flywheel housing gasket	1	
13	480G-01600	油尺套管焊接部件	Dipstick sleeve weldment	1	
14	480G-01400	机油尺部件	Oil level dipstick	1	
15	480G-01007	曲轴止推片 (上)	Upper thrust piece of crankshaft	2	
16	480G-01008	曲轴止推片 (下)	Lower thrust piece of crankshaft	2	
17	480G-01015	主轴瓦上瓦	Main bearing halfshell (upper)	3	
18	480G-01016	主轴瓦下瓦	Main bearing halfshell (lower)	3	
19	480G-01113	后主轴承盖	Rear main bearing cap	1	
20	480G-01114	主轴承螺栓垫圈	Main bearing bolt washer	6	

序号 Ser No	图号 Parts No	名称 Name of Parts	数量 Qty	附注 Remarks	
21	480G-01115	主轴承盖螺栓	Main bearing cap bolt	6	
22	480G-01300	放水开关部件	Water drain cock	1	
23	480G-01104	碗形塞片	Bowl-shaped plug piece	3	
24	480G-01500	压力表用传感器部件	Sensor for oil gauge	1	
25	GB5782-86	螺栓 M8×65	Bolt M8×65	1	
26	GB5782-86	螺栓 M8×45	Bolt M8×45	1	
27	480G-01004	机油滤清器垫片	Oil filter gasket	2	
28	280-01026	机油滤清器接头	Coupling of oil filter	1	
29	480G-01106	Z 1/8" 圆锥螺塞	Z 1/8" taper plug	3	
30	480G-01105	Z 1/4" 圆锥螺塞	Z 1/4" taper plug	2	
31	280-01017	支承脚	Stand bar	2	
32	GB5783-86	螺栓 M10×30	Bolt M10×30	12	
33	GB848-85	垫圈 10-140HV	Washer 10-140HV	14	
34	480G-01107	碗形塞片	Bowl-shaped plug piece	1	
35	480G-01112	主轴承盖	Main bearing cap	2	
36	GB119-86	销 B10×20	Pin B10×20	2	
37	480G-01108	堵塞	Stopper	2	
38	480G-01024	凸轮轴前衬套	Front camshaft bush	1	
39	480G-01026	凸轮轴后衬套	Rear camshaft bush	1	
40	480G-01109	碗形塞片	Bowl-shaped plug piece	2	

序号 Ser No	图号 Parts No	名称	Name of Parts	数量 Qty	附注 Remarks
41	GB5782-86	螺栓 M8×60	Bolt M8×60	8	
42	GB5782-86	螺栓 M8×55	Bolt M8×55	4	
43	GB119-86	销 B8×20	Pin B8×20	1	
44	GB5783-86	螺栓 M8×20	Bolt M8×20	23	
45	GB827-86	铆钉 2×5	Rivet 2×5	4	
46	280-01020	标牌	Name plate	1	
47	480G-01103	碗形塞片	Bowl-shaped plug piece	2	
48	GB5783-86	螺栓 M10×25	Bolt M8×25	2	
49	GB62-88	蝶形螺母 M6	Butterfly nut M6	1	
50	GB848-85	垫圈 6-140HV	Washer 6-140HV	1	
51	480G-01201	呼吸器盖	Respirator cover	1	
52	480G-01203	滤网	Filter gauze	1	
53	480G-01202	呼吸器隔板	Respirator partition	1	
54	480G-01210	呼吸器焊接件	Respirator weldment	1	
55	480G-01011	呼吸器垫片	Respirator gasket	1	
56	480G-01703	放油螺塞	Oil drain plug	1	
57	480G-01704	垫圈	Washer	1	
58	280-01701	油底壳	Oil sump	1	
59	280-01018	油底壳垫片	Oil sump gasket	1	
60	280-01010	飞轮壳	Flywheel housing	1	



序号 Ser No	图号 Parts No	名称 Name of Parts	数量 Qty	附注 Remarks
61	GB67-85	螺钉 M6×12 Screw M6×12	2	
62	GB97.1-85	垫圈 6-140HV Washer 6-140HV	2	
63	480G-01019	盖板 Cover plate	1	
64	GB5783-86	螺栓 M8×30 Bolt M8×30	2	
65	HG4-692-67	骨架式橡胶油封 PG80×100×12 Cased rubber oil seal PG80×100×12	1	

4.正时齿轮室总成 (480, 380, 280) Timing Gear Case Assy(480, 380, 280)

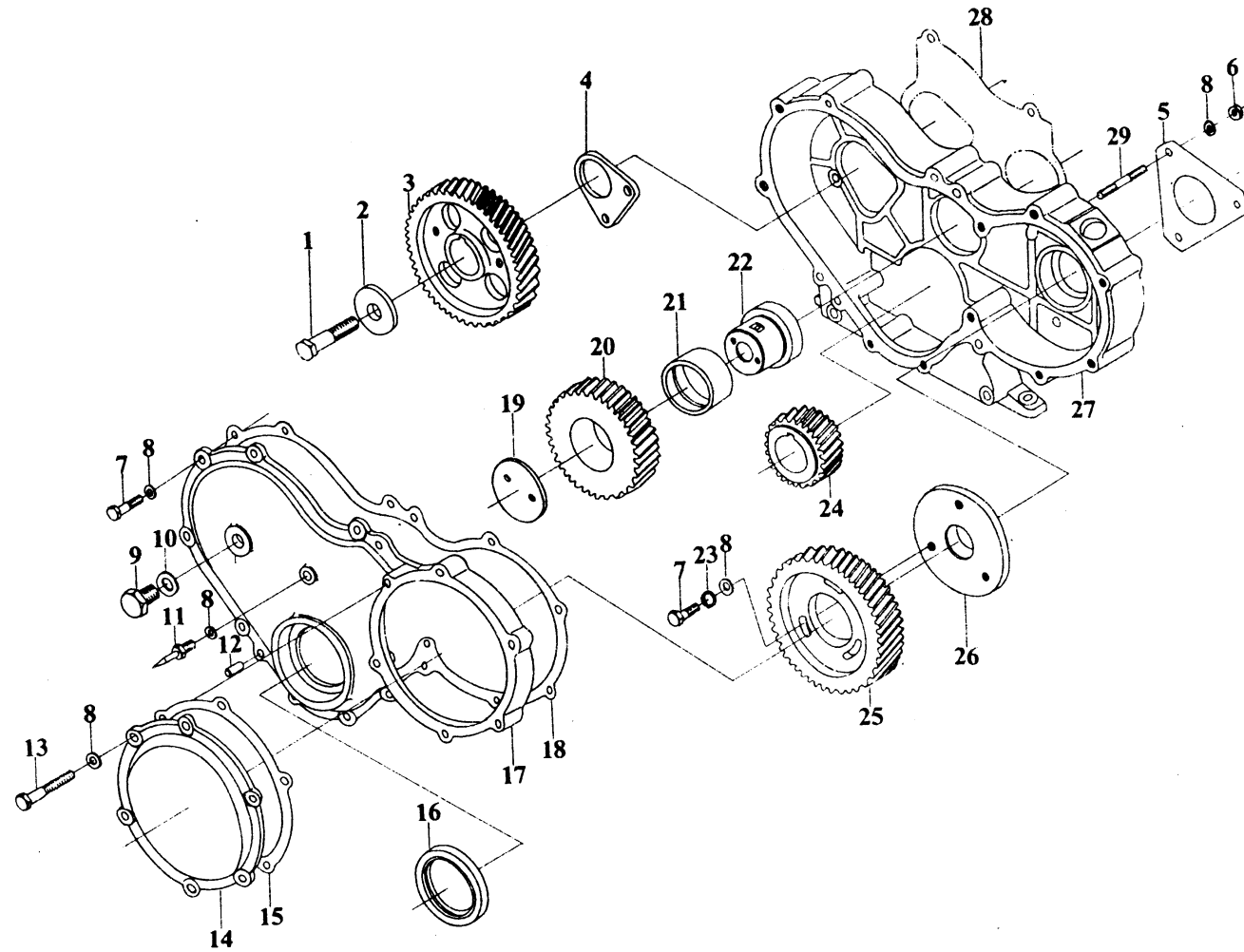

4.正时齿轮室总成 (480, 380, 280) Timing Gear Case Assy(480, 380, 280)

序号 Ser No	图号 Parts No	名称 Name of Parts	数量 Qty	附注 Remarks
1	GB5783-86	螺栓 M12×30 Bolt M12×30	1	属 06 部件 Belong to 06 unit
2	480G-02012	凸轮轴正时齿轮压板 Camshaft timing gear holddown	1	
3	480G-02011	凸轮轴正时齿轮 Camshaft timing gear	1	
4	480G-02010	凸轮轴止推板 Camshaft thrust plate	1	
5	480G-02002	喷油泵垫片 Fuel injection pump gasket	1	
6	GB6170-86	螺母 M8 Nut M8	3	
7	GB5783-86	螺栓 M8×20 Bolt M8×20	7	
8	GB848-85	垫圈 8-140HV Washer 8-140HV	17	
9	480G-01703	放油螺塞 Oil drain plug	1	
10	480G-01704	垫圈 Washer	1	
11	480G-02015	指针 Pointer	1	
12	GB119-86	销 B8×20 Pin B8×20	2	
13	GB5782-86	螺栓 M8×40 Bolt M8×40	6	
14	480G-02017	正时齿轮室前盖 Front cover of timing gear case	1	
15	480G-02016	正时齿轮室前盖垫片 Front cover gasket of timing gear case	1	
16	HG4-692-67	油封 PG55×75×12 或 Oil seal PG55×75×12 or SG55×75×12 SG55×75×12	1	
17	480G-02013	正时齿轮室盖 Timing gear case cover	1	
18	480G-02014	正时齿轮室盖垫片 Timing gear case cover gasket	1	
19	480G-02008	惰齿轮压板 Idle gear holddown	1	

序号 Ser No	图号 Parts No	名称 Name of Parts	数量 Qty	附注 Remarks
20	480G-02005	正时惰齿轮	Timing idle gear	1
21	480G-02006	正时惰齿轮衬套	Timing idle gear bush	1
22	480G-02007	正时惰齿轮轴	Timing idle gear shaft	1
23	GB859-87	垫圈 8	Washer 8	3
24	480G-02009	曲轴正时齿轮	Crankshaft timing gear	1
25	480G-02003	喷油泵正时齿轮	Fuel injection pump timing gear	1
26	480G-02004	喷油泵正时齿轮座	Fuel injection pump timing gear seat	1
	280-02004	喷油泵正时齿轮座	Fuel injection pump timing gear seat	1
27	480G-02001	正时齿轮室	Timing gear case	1
	280-02001	正时齿轮室	Timing gear case	1
28	480G-01001	正时齿轮室垫片	Timing gear case gasket	1
29	GB898-88	双头螺柱 M8 × 20	Stud M8 × 20	3

480G, 380 用  
For 480G, 380  
280 用, For 280  
480G, 380 用  
For 480G, 380  
280 用, For 280  
属 01 部件  
Belong to 01 unit

### 5. 气缸盖总成(480、380、280) I Cylinder Head Assy (480、380、280) I

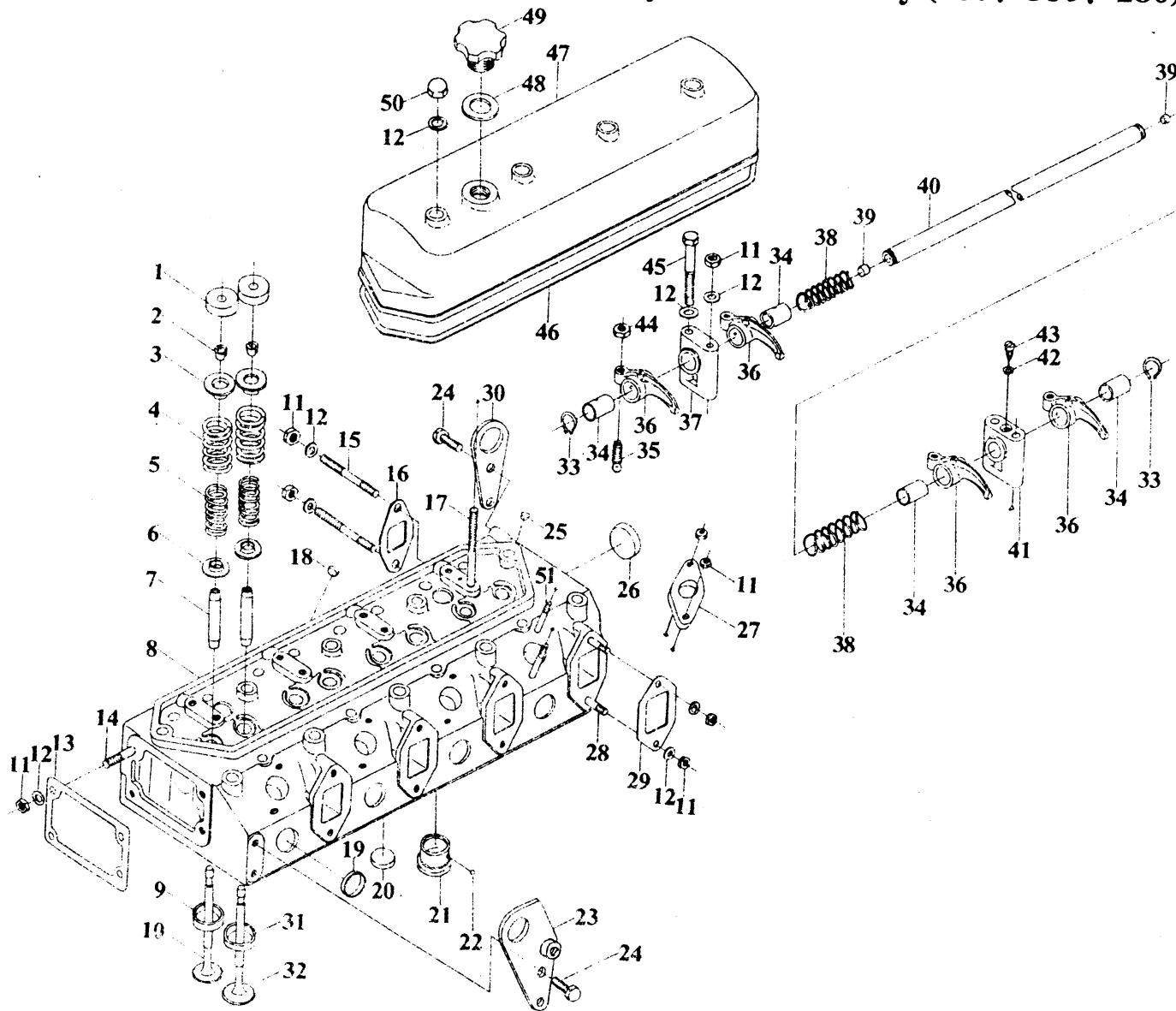

### 5. 气缸盖总成(480、380、280) I    Cylinder Head Assy (480、380、280) I

序号 Ser No	图号 Parts No	名称 Name of Parts	数量 Qty			附注 Remarks
			480	380	280	
1	480G-03019	弹簧上座盖	8	6	4	
2	480G-03008	气门锁夹	16	12	8	
3	480G-03009	气门弹簧上座	8	6	4	
4	480G-03007	气门外弹簧	8	6	4	
5	480G-03017	气门内弹簧	8	6	4	
6	480G-03018	气门弹簧下座	8	6	4	
7	480G-03102	气门导管	8	6	4	
8	480G-03101	气缸盖	1			
	380-03101	气缸盖		1		
	280-03101	气缸盖			1	
9	480G-03104	排气门座	4	3	2	
10	480G-03015	排气门	4	3	2	
11	GB6170-86	螺母 M8	36	25	18	
12	GB848-85	垫圈 8-140HV	32	25	18	
13	480G-03016	节温器壳垫片	1	1	1	
14	GB898-88	双头螺柱 M8×25	4	4	4	
15	GB898-88	双头螺柱 M8×30	8	6	4	
16	480G-03006	排气管垫片	4	3	2	
17	480G-03001	摇臂座固定螺栓	4	3	2	
18	480G-01107	碗形塞片 (Φ10)	4	3	2	

序号 Ser No	图号 Parts No	名称	Name of Parts	数量 Qty			附注 Remarks
				480	380	280	
19	480G-01103	碗形塞片 (Φ25)	Bowl-shaped plug piece (Φ25)	4	3	2	
20	480G-03106	碗形塞片 (Φ20)	Bowl-shaped plug piece (Φ20)	1			
21	480G-03105	涡流室镶块	Swirl-chamber splice block	4	3	2	
22	GB308-84	钢球 Φ3	Steel ball Φ3	4	3	2	
23	480G-03300	前吊环焊接部件	Front hoisting ring weldment	1	1	1	
24	GB5783-86	螺栓 M8 × 20	Bolt M8 × 20	4	4	4	
25	480G-01108	堵塞	Stopper	1	1	1	
26	480G-01104	碗形塞片 (Φ32)	Bowl-shaped plug piece (Φ32)	1	1	1	
27	195-03013	喷油器压板	Injector holddown	4	3	2	
28	480G-03020	双头螺柱	Stud	8	6	4	
29	480G-03013	进气管垫片	Intake pipe gasket	4	3	2	
30	480G-03012	后吊环	Rear hoisting ring	1	1	1	
31	480G-03103	进气门座	Intake valve seat	4	3	2	
32	480G-03014	进气门	Intake valve	4	3	2	
33	GB894.1-86	挡圈 16	Check ring 16	2	2	2	
34	480G-03208	摇臂衬套	Rocker arm bush	8	6	4	
35	480G-03201	气门间隙调整螺钉	Valve clearance adjusting screw	8	6	4	
36	480G-03203	气门摇臂	Valve rocker arm	8	6	4	
37	480G-03202	摇臂轴支座	Rockshaft carrier	3	2	1	
38	480G-03204	摇臂轴弹簧	Rockshaft spring	3	2	1	

序号 Ser No	图号 Parts No	名称 Name of Parts	数量 Qty			附注 Remarks
			480	380	280	
39	480G-03210-2	摇臂轴堵头	2	2	2	
40	480G-03210-1	摇臂轴	1			
	380-03210	摇臂轴		1		
	280-03210	摇臂轴			1	
41	480G-03207	摇臂轴后支座	1	1	1	
42	GB848-85	垫圈 6—140HV	1	1	1	
43	480G-03206	摇臂轴定位螺钉	1	1	1	
44	GB6171-86	螺母 M8×1	8	6	4	
45	GB5782-86	螺栓 M8×60	4	3	2	
46	480G-03005	气缸盖罩垫片	1			
	380-03005	气缸盖罩垫片		1		
	280-03005	气缸盖罩垫片			1	
47	480G-03004	气缸盖罩	1			
	380-03209	气缸盖罩		1		
	280-03209	气缸盖罩			1	
48	480G-03003	加油口盖垫片	1	1	1	
49	480G-03002	加油口盖	1	1	1	
50	GB923-88	盖形螺母 M8	4	3	2	
51	GB898-88	双头螺柱 M8×65	8	6	4	



6. 气缸盖总成(480、380、280)Ⅱ(带减压装置)  
 Cylinder Head Assy (480、380、280)Ⅱ (with Pressure-Reducing Device)

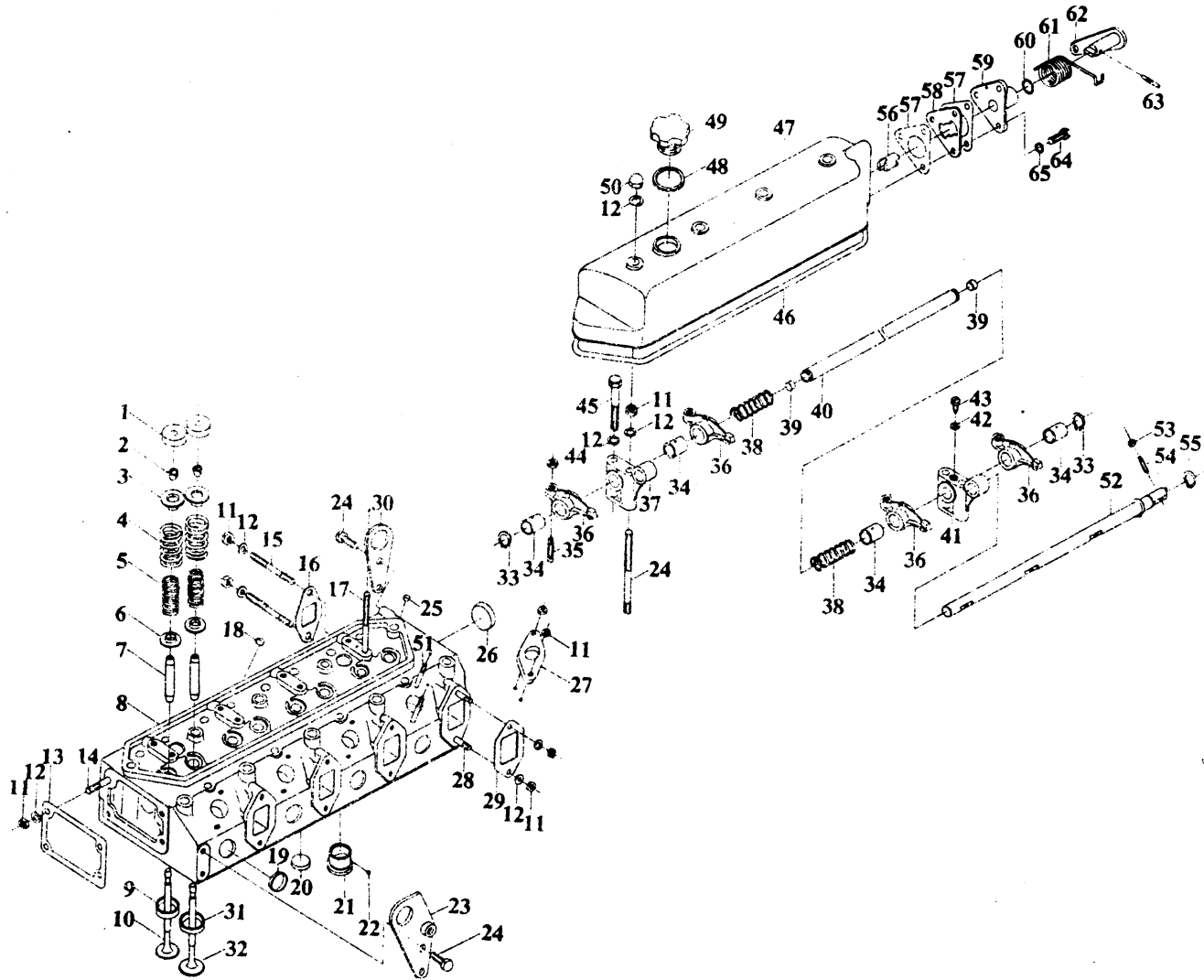

**6.气缸盖总成(480、380、280)Ⅱ(带减压装置)**  
**Cylinder Head Assy (480、380、280)Ⅱ (with Pressuer-Reducing Device)**

序号 Ser No	图号 Parts No	名称 Name of Parts	数量 Qty			附注 Remarks
			480	380	280	
1	480G-03019	弹簧上座盖	8	6	4	
2	480G-03008	气门锁夹	16	12	8	
3	480G-03009	气门弹簧上座	8	6	4	
4	480G-03007	气门外弹簧	8	6	4	
5	480G-03017	气门内弹簧	8	6	4	
6	480G-03018	气门弹簧下座	8	6	4	
7	480G-03102	气门导管	8	6	4	
8	480G-03101	气缸盖	1			
	380-03101	气缸盖		1		
	280-03101	气缸盖			1	
9	480G-03104	排气门座	4	3	2	
10	480G-03015	排气门	4	3	2	
11	GB6170-86	螺母 M8	36	25	18	
12	GB848-85	垫圈 8-140HV	32	25	18	
13	480G-03016	节温器壳垫片	1	1	1	
14	GB898-88	双头螺柱 M8×25	4	4	4	
15	GB898-88	双头螺柱 M8×30	8	6	4	
16	480G-03006	排气管垫片	4	3	2	
17	480G-03001	摇臂座固定螺栓	4	3	2	
18	480G-01107	碗形塞片 (Φ10)	4	3	2	

序号 Ser No	图号 Parts No	名称 Name of Parts	数量 Qty			附注 Remarks	
			480	380	280		
19	480G-01103	碗形塞片 (Φ25)	Bowl-shaped plug piece (Φ25)	6	3	2	
20	480G-03106	碗形塞片 (Φ20)	Bowl-shaped plug piece (Φ20)	1			
21	480G-03105	涡流室镶块	Swirl-chamber splice block	4	3	2	
22	GB308-84	钢球 Φ3	Steel ball Φ3	4	3	2	
23	480G-03300	前吊环焊接部件	Front hoisting ring weldment	1	1	1	
24	GB5783-86	螺栓 M8×20	Bolt M8×20	4	4	4	
25	480G-01108	堵塞	Stopper	1	1	1	
26	480G-01104	碗形塞片 (Φ32)	Bowl-shaped plug piece (Φ32)	1	1	1	
27	195-03013	喷油器压板	Injector holddown	4	3	2	
28	480G-03020	双头螺柱	Stud	8	6	4	
29	480G-03013	进气管垫片	Intake pipe gasket	4	3	2	
30	480G-03012	后吊环	Rear hoisting ring	1	1	1	
31	480G-03103	进气门座	Intake valve seat	4	3	2	
32	480G-03014	进气门	Intake valve	4	3	2	
33	GB894.1-86	挡圈 16	Check ring 16	2	2	2	
34	480G-03208	摇臂衬套	Rocker arm bush	8	6	4	
35	480G-03201	气门间隙调整螺钉	Valve clearance adjusting screw	8	6	4	
36	480G-03203	气门摇臂	Valve rocker arm	8	6	4	
37	480Q-5-03202	摇臂轴支座	Rockshaft carrier	3	2	1	
38	480G-03204	摇臂轴弹簧	Rockshaft spring	3	2	1	

序号 Ser No	图号 Parts No	名称 Name of Parts	数量 Qty			附注 Remarks
			480	380	280	
39	480G-03210-2	摇臂轴堵头	2	2	2	
40	480G-03210-1	摇臂轴	1			
	380-03210-1	摇臂轴		1		
	280-03210-1	摇臂轴			1	
41	480Q-5-03207	摇臂轴后支座	1	1	1	
42	GB848-85	垫圈 6—140HV	1	1	1	
43	480G-03206	摇臂轴定位螺钉	1	1	1	
44	GB6171-86	螺母 M8×1	8	6	4	
45	GB5782-86	螺栓 M8×60	4	3	2	
46	480G-03005	气缸盖罩垫片	1			
	380-03005	气缸盖罩垫片		1		
	280-03005	气缸盖罩垫片			1	
47	480Q-5-03209	气缸盖罩	1			
	380-03209	气缸盖罩		1		
	280-03209	气缸盖罩			1	
48	480G-03003	加油口盖垫片	1	1	1	
49	480G-03002	加油口盖	1	1	1	
50	GB923-88	盖形螺母 M8	4	3	2	
51	GB898-88	双头螺柱 M8×65	8	6	4	

序号 Ser No	图号 Parts No	名称 Name of Parts	数量 Qty			附注 Remarks
			480	380	280	
52	480Q-5-03211	减压轴	Decompression shaft	1		
	380-03211	减压轴	Decompression shaft		1	
	280-03211	减压轴	Decompression shaft			1
53	GB6171-86	螺母 M8×1	Nut M8×1	12	9	6
54	480Q-5-03217	减压调整螺钉	Decompression adjusting screw	4	3	2
55	GB894.1-86	挡圈 14	Check ring 14	2	2	2
56	480Q-5-03218	十字接头	Cross connection	1	1	1
57	480Q-5-03212	垫片	Gasket	2	2	2
58	480Q-5-03213	减压器控制板	Decompressor control plate	1	1	1
59	480Q-5-03216	减压摇臂轴套	Decompression rocker arm bush	1	1	1
60	GB3452.1-82	"O"形密封圈	O-ring seal	1	1	1
		13.2×2.65	13.2×2.65			
61	480Q-5-03215	扭力弹簧	Torsion spring	1	1	1
62	480Q-5-03220	减压摇臂焊接件	Decompression rocker arm weldment	1	1	1
63	480Q-5-03214	限位销	Limiting pin	1	1	1
64	GB5783-86	螺栓 M8×25	Bolt M8×25	3	3	3
65	GB859-87	垫圈 8	Washer 8	3	3	3

## 7. 活塞连杆总成(480, 380, 280) Piston-connecting Rod Assy (480, 380, 280)

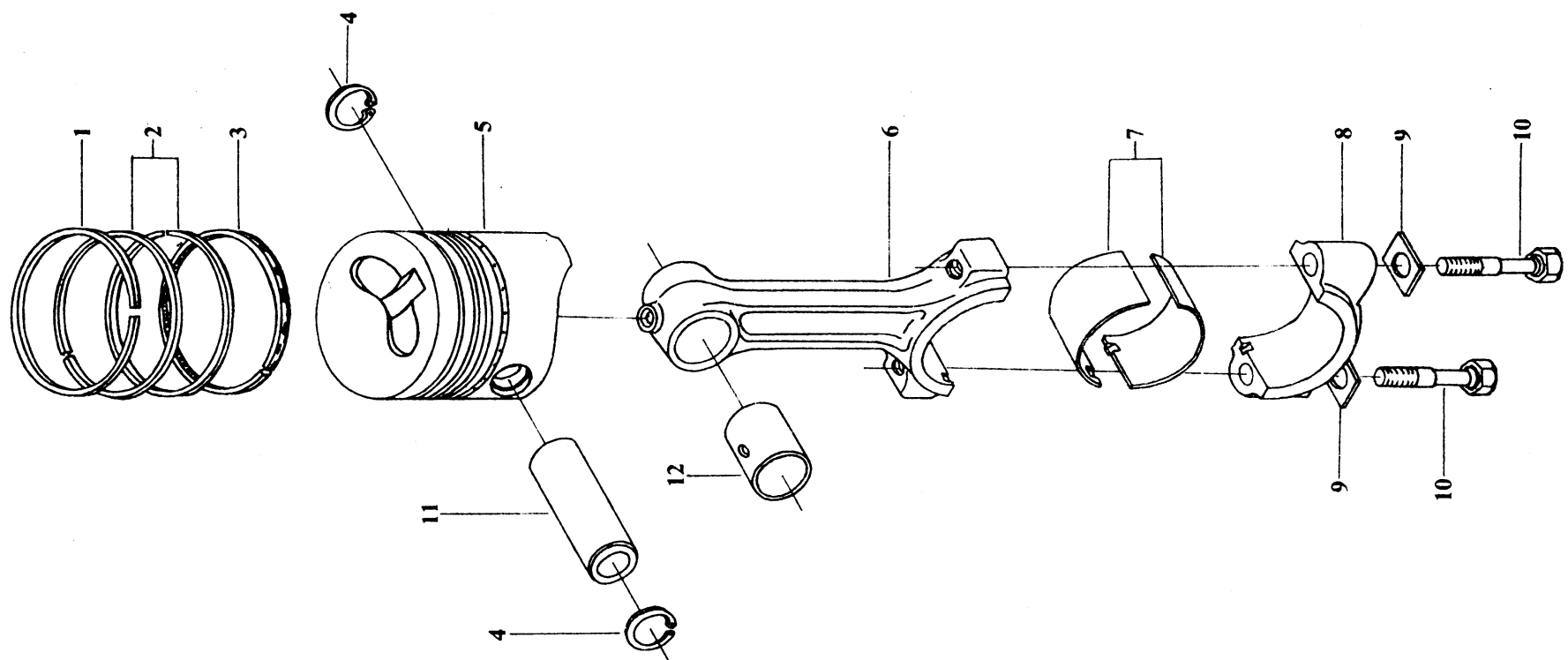

7. 活塞连杆总成(480, 380, 280) Piston-connecting Rod Assy (480, 380, 280)

序号 Ser No	图号 Parts No	名称 Name of Parts	数量 Qty	附注 Remarks
1	480G-04001	第一道气环 Top compression ring	1×n	n 为气缸数
2	480G-04002	第二、三道气环 2nd and 3rd compression ring	2×n	
3	480G-04100	油环部件 Oil ring unit	1×n	
4	GB893.1-86	孔用弹性挡圈 26 Circlip for hole 26	2×n	
5	480G-04005	活塞 Piston	1×n	
6	480G-04202	连杆 Connecting rod	1×n	
7	480G-04003	连杆轴瓦 Connecting rod bearing shell	2×n	
8	480G-04203	连杆盖 Connecting rod cap	1×n	
9	480G-04205	连杆螺栓锁片 Connecting rod bolt lock plate	2×n	
10	480G-04204	连杆螺栓 Connecting rod bolt	2×n	
11	480G-04004	活塞销 Piston pin	1×n	
12	480G-04201	连杆衬套 Connecting rod bush	1×n	

注: 480—n 为 4    380—n 为 3    280—n 为 2

8.曲轴飞轮总成(480、380、280) Crankshaft-flywheel Assy (480、380、280)

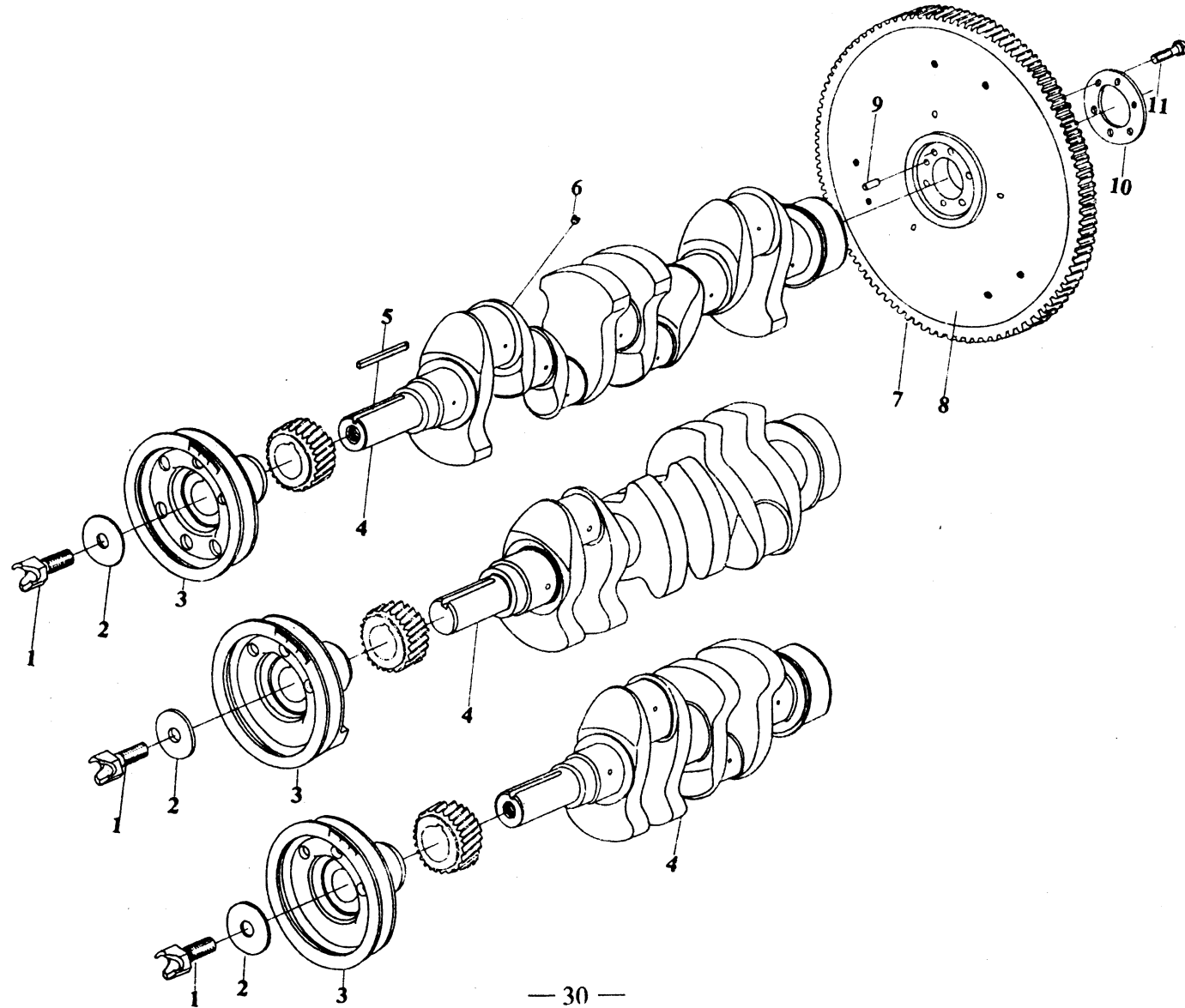



### 8.曲轴飞轮总成(480、380、280) Crankshaft-flywheel Assy (480、380、280)

序号 Ser No	图号 Parts No	名称 Name of Parts	数量 Qty			附注 Remarks	
			480	380	280		
1	480G-05007	起动爪	Starting claw	1	1	1	
2	480G-05006	起动爪垫板	Starting claw backing plate	1	1	1	
3	480G-05005	曲轴皮带轮	Crankshaft belt pulley	1			
	380-05005	曲轴皮带轮	Crankshaft belt pulley		1		
	280-05005	曲轴皮带轮	Crankshaft belt pulley			1	
4	480G- <sup>05003</sup> <sub>05003A</sub>	曲轴	Crankshaft	1			05003,05003A 仅材质 不同, 可通用 (Interchangeable, on- ly different materials used)
	380- <sup>05003</sup> <sub>05003A</sub>	曲轴	Crankshaft		1		
	280- <sup>05003</sup> <sub>05003A</sub>	曲轴	Crankshaft			1	
5	GB1096-79	键 C10×64	Key C10×64	1	1	1	
6	480G-05004	螺塞	Plug	4	3	2	
7	480G-05102	飞轮齿圈	Flywheel gear ring	1	1	1	
8	480G-05101	飞轮	Flywheel	1			
	380-05101	飞轮	Flywheel		1		
	280-05101	飞轮	Flywheel			1	
9	GB119-86	销 B8×20	Pin B8×20	1	1	1	
10	480G-05002	飞轮螺栓垫板	Flywheel bolt backing plate	1	1	1	
11	480G-05001	飞轮螺栓	Flywheel bolt	6	6	6	

9. 凸轮轴总成 (480, 380, 280) Camshaft Assy (480, 380, 280)

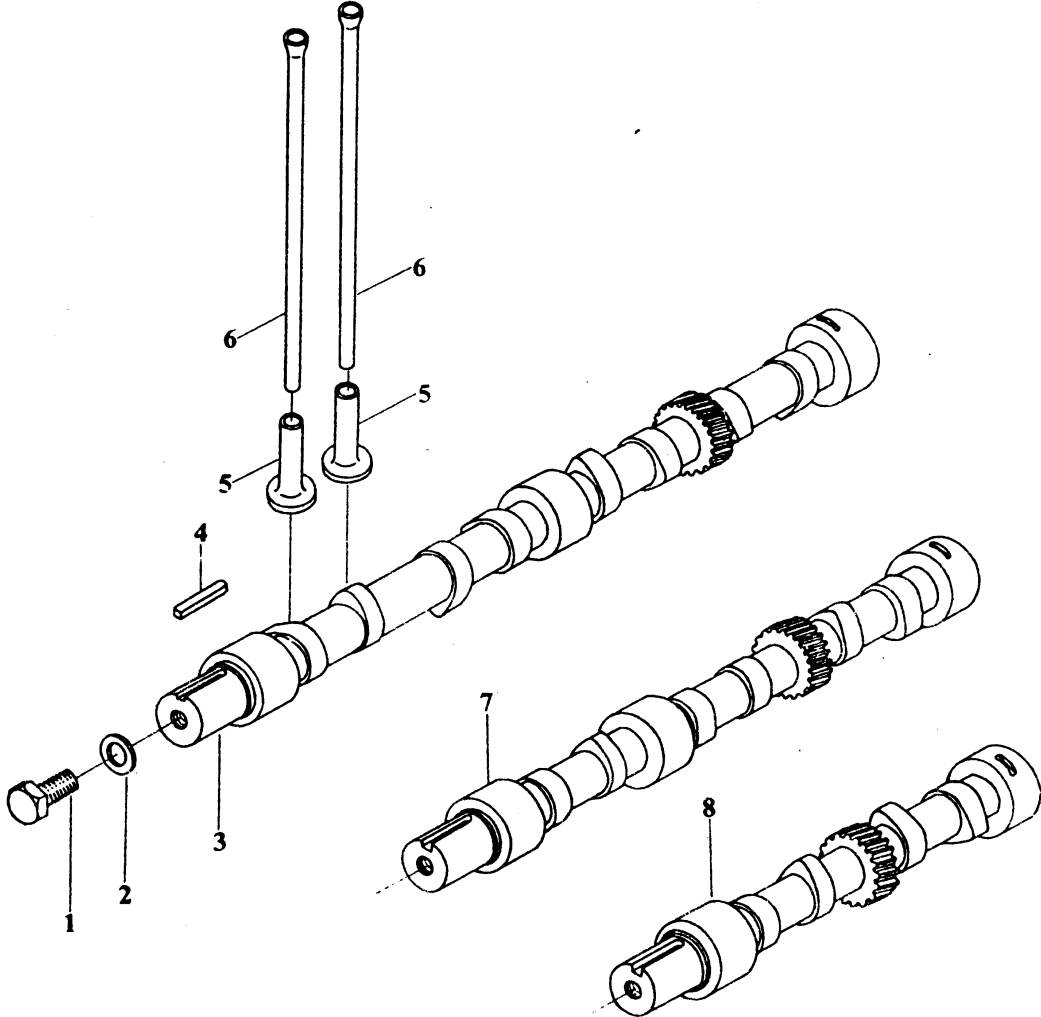

9.凸轮轴总成 (480, 380, 280) Camshaft Assy (480, 380, 280)

序号 Ser No	图号 Parts No	名称 Name of Parts	数量 Qty			附注 Remarks
			480	380	280	
1	GB5783-86	螺栓 M12×30 Bolt M12×30	1	1	1	06001, 06001A 仅材质不同, 可通用 (Interchangeable, only different materials used)
2	GB848-85	垫圈 12-140HV Washer 12-140HV	1	1	1	
3	480G-06001 -06001A	凸轮轴 Camshaft 凸轮轴 Camshaft	1			
4	GB1096-79	键 C8×22 Key C8×22	1	1	1	06002, 06002A 仅材质不同, 可通用 (Interchangeable, only different materials used)
5	480G-06002 -06002A	挺柱 Tappet 挺柱 Tappet	8	6	4	
6	480G-06003	推杆 Push rod	8	6	4	
7	380-06001 -06001A	凸轮轴 Camshaft		1		同上
8	280-06001 -06001A	凸轮轴 Camshaft			1	同上

10.进气管总成 (480, 380, 280) Intake Pipe Assy (480, 380, 280)

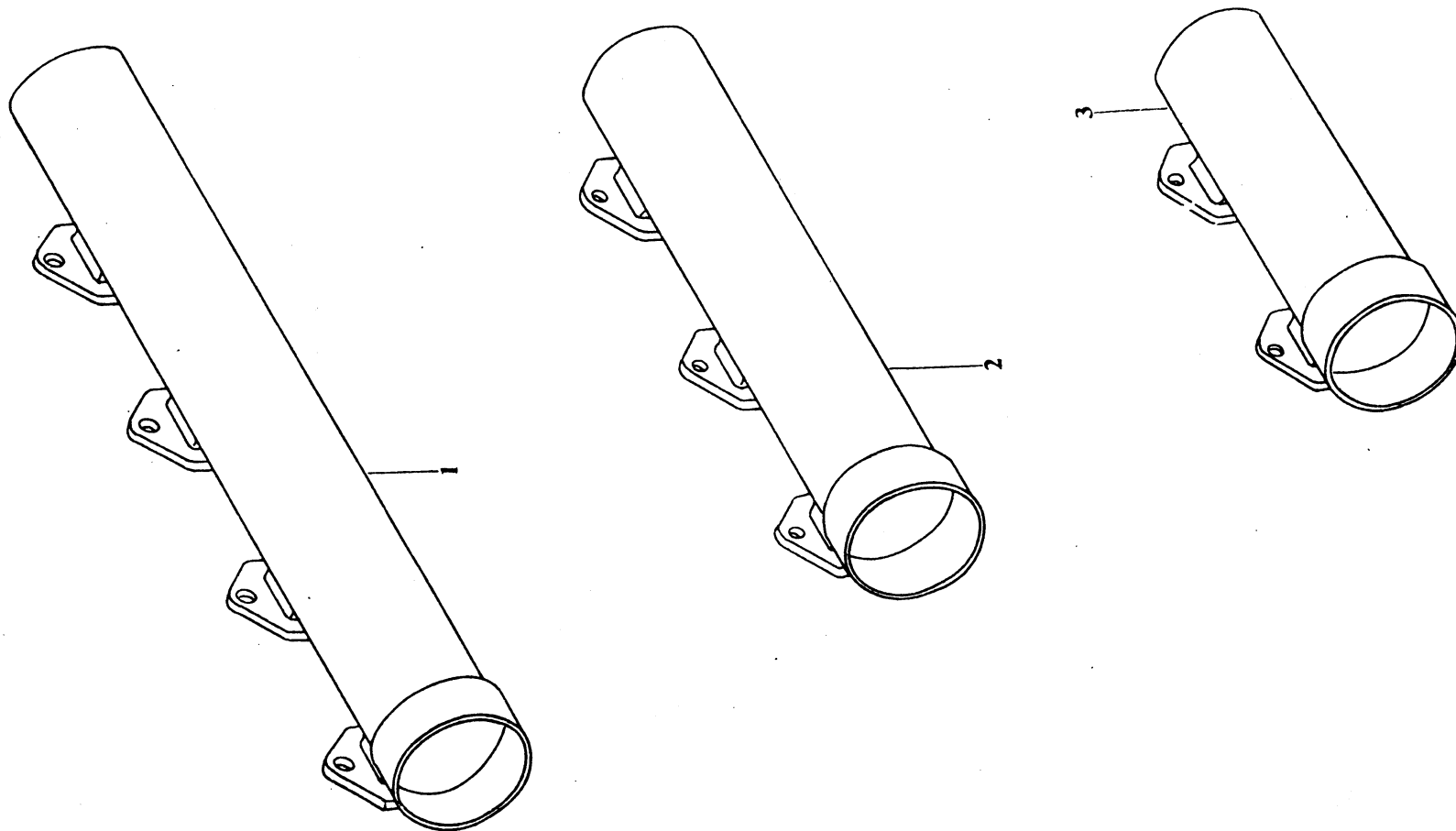

10.进气管总成 (480, 380, 280) Intake Pipe Assy (480, 380, 280)

序号 Ser No	图号 Parts No	名称 Name of Parts	数量 Qty			附注 Remarks
			480	380	280	
1	480G-07000	进气管总成 Intake pipe assy	1			
2	380-07000	进气管总成 Intake pipe assy		1		
3	280-07000	进气管总成 Intake pipe assy			1	

11.排气管总成 (480, 380, 280) Exhaust Pipe Assy (480, 380, 280)

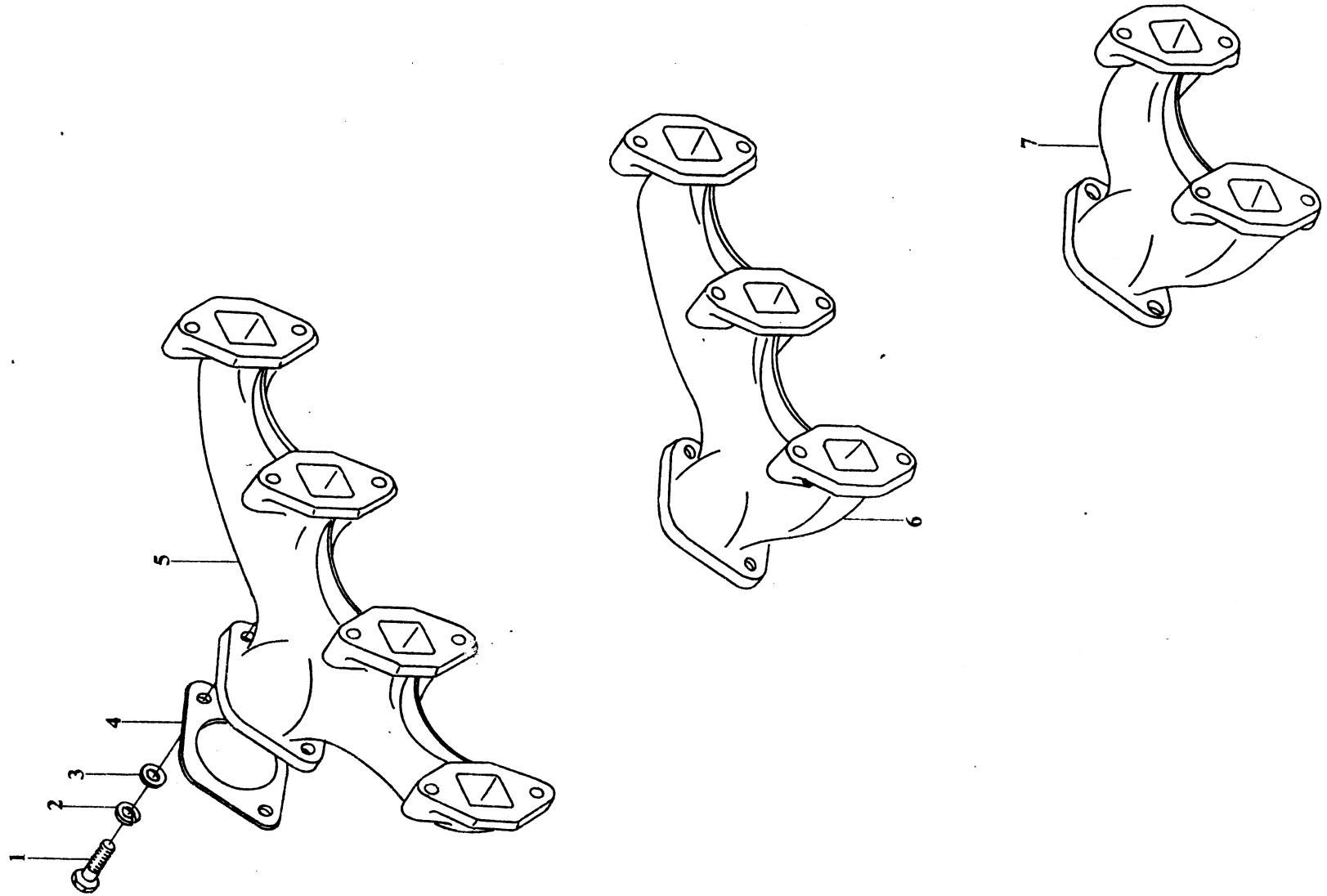

11.排气管总成 (480, 380, 280) Exhaust Pipe Assy (480, 380, 280)

序号 Ser No	图号 Parts No	名称 Name of Parts	数量 Qty			附注 Remarks
			480	380	280	
1	GB5783-86	螺栓 M10×30 Bolt M10×30	2	2	2	
2	GB859-87	垫圈 10 Washer 10	2	2	2	
3	GB848-85	垫圈 10-140HV Washer 10-140HV	2	2	2	
4	480G-08002	排气总管垫片 General exhaust pipe gasket	1	1	1	
5	480G-08001	排气管 Exhaust pipe	1			
6	380-08001	排气管 Exhaust pipe		1		
7	280-08001	排气管 Exhaust pipe			1	

12. 润滑系统总成 (480, 380, 280) Lubricating System Assy (480, 380, 280)

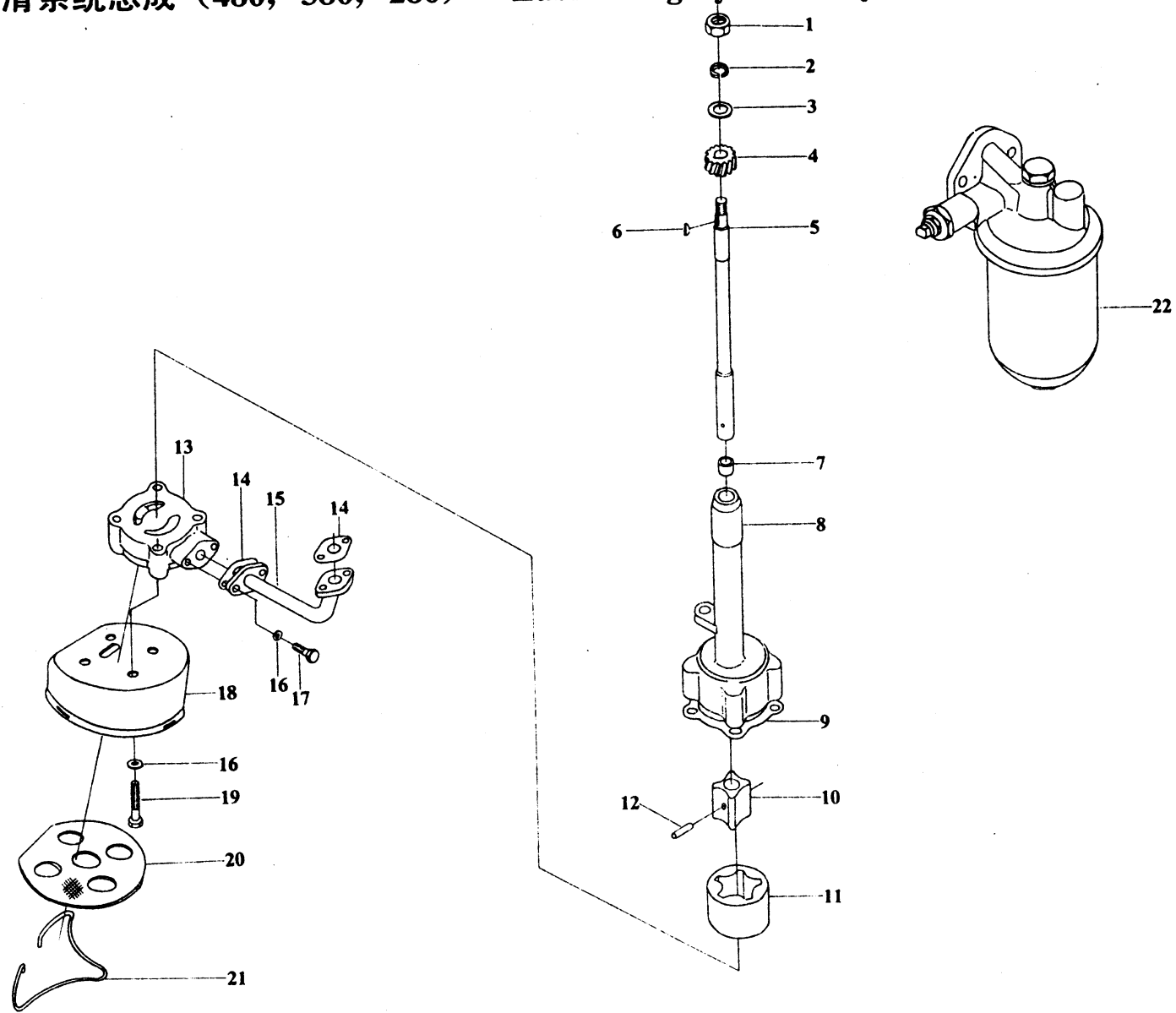



12.润滑系统总成 (480, 380, 280) Lubricating System Assy (480, 380, 280)

序号 Ser No	图号 Parts No	名称 Name of Parts	数量 Qty	附注 Remarks	
1	GB6170-86	螺母 M10	Nut M10	1	
2	GB93-87	垫圈 10	Washer 10	1	
3	GB848-85	垫圈 10-140HV	Washer 10-140HV	1	
4	480G-09101	机油泵传动齿轮	Oil pump drive gear	1	
5	480G-09111	机油泵轴	Oil pump shaft	1	
6	GB1099-79	半圆键 3×5×13	Semicircular key 3×5×13	1	
7	480G-09102	机油泵体衬套	Oil pump body bush	1	
8	480G-09103	机油泵体	Oil pump body	1	
9	480G-09105	机油泵垫片	Oil pump gasket	1	
10	480G-09112	内转子	Inner rotor	1	
11	480G-09104	外转子	Outer rotor	1	
12	480G-09113	圆柱销	Cylindrical pin	1	
13	480G-09106	机油泵盖	Oil pump cover	1	
14	480G-09002	出油管法兰垫片	Oil outlet pipe flange gasket	2	
15	480G-09400	机油管路部件	Oil line unit	1	
16	GB848-85	垫圈 8-140HV	Washer 8-140HV	6	
17	GB5783-86	螺栓 M8×20	Bolt M8×20	2	
18	480G-09001	滤网体	Gauze filter body	1	
19	GB5782-86	螺栓 M8×40	Bolt M8×40	4	
20	480G-09200	滤网焊合件	Gauze filter weldment	1	

序号 Ser No	图号 Parts No	名称 Name of Parts	数量 Qty	附注 Remarks
21	480G-09003	滤油网撑 Gauze support	1	
22	480G-09300	机油滤清器总成 Oil filter assy	1	型号 J0810H Model J0810H

### 13.燃油系统总成(480、380、280) Fuel System Assy (480、380、280)

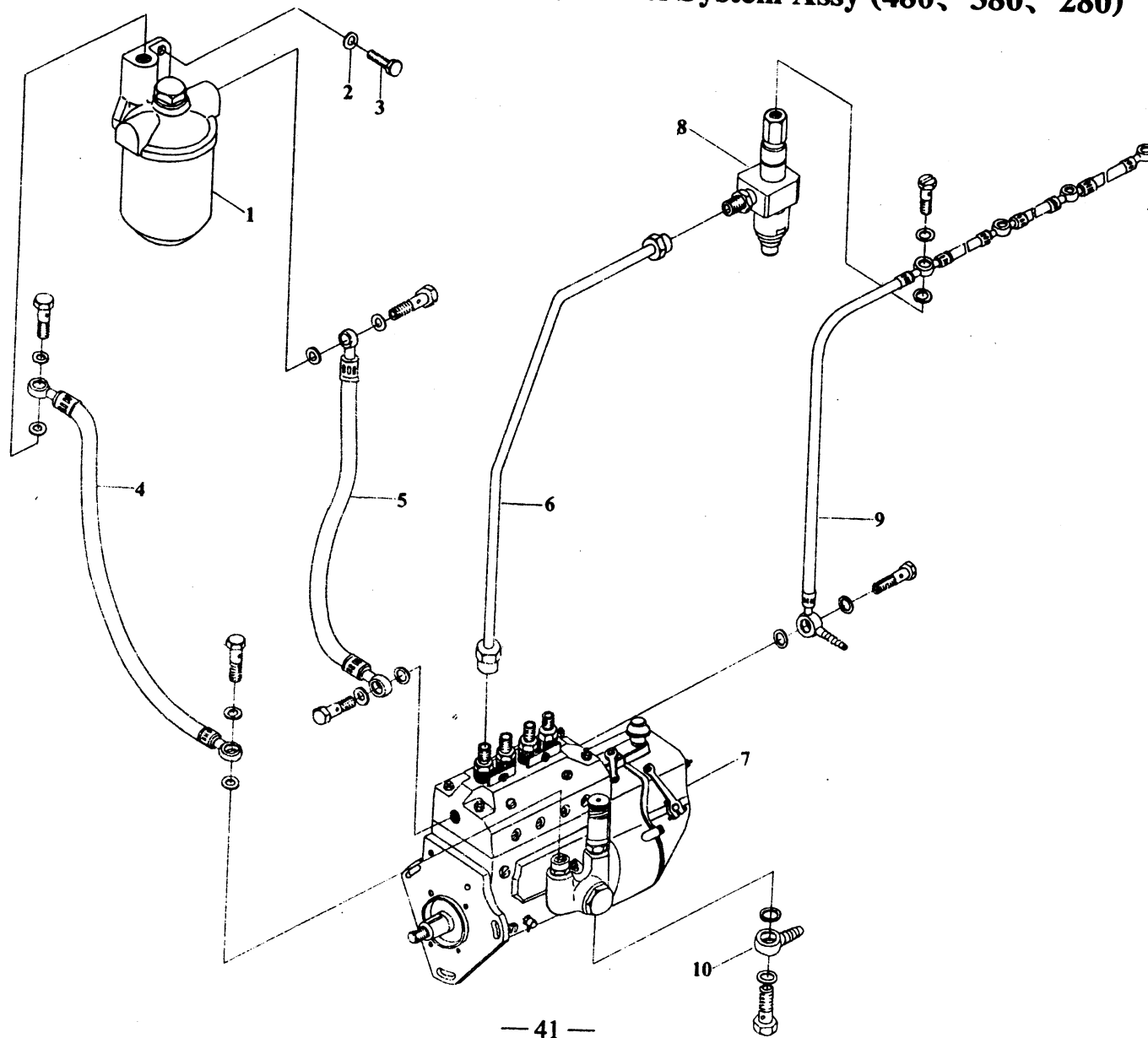

### 13.燃油系统总成(480、380、280) Fuel System Assy (480、380、280)

序号 Ser No	图号 Parts No	名称 Name of Parts	数量 Qty			附注 Remarks	
			480	380	280		
1	480G-10500	燃油滤清器总成	Fuel filter assy	2	2	2	同 S195 型 The same with Model S195
2	GB848-85	垫圈 8-140HV	Washer 8-140HV	1	1	1	
3	GB5783-86	螺栓 M8×25	Bolt M8×25	1	1	1	
4	480G-10700	喷油泵至滤清器油管部件	Lines from injection pump to filter	1	1	1	
5	480G-10600	滤清器至喷油泵油管部件	Lines from filter to injection pump	1	1	1	
6	480G-10200	高压油管部件	Fuel injection pipe	4	3	2	
7	480G-10100	喷油泵总成	Injection pump assy	1			
	380-10100	喷油泵总成	Injection pump assy		1		
	280-10100	喷油泵总成	Injection pump assy			1	
8	P662-00MX	喷油器总成	Injector assy	4	3	2	
9	480G-10400	回油管部件	Fuel return pipe	1			
	380-10400	回油管部件	Fuel return pipe		1		
	280-10400	回油管部件	Fuel return pipe			1	
10	480G-10001	喷油泵接头	Injection pump fittings	1	1	1	

14.冷却系统总成(480, 380, 280) Cooling System Assy (480, 380, 280)

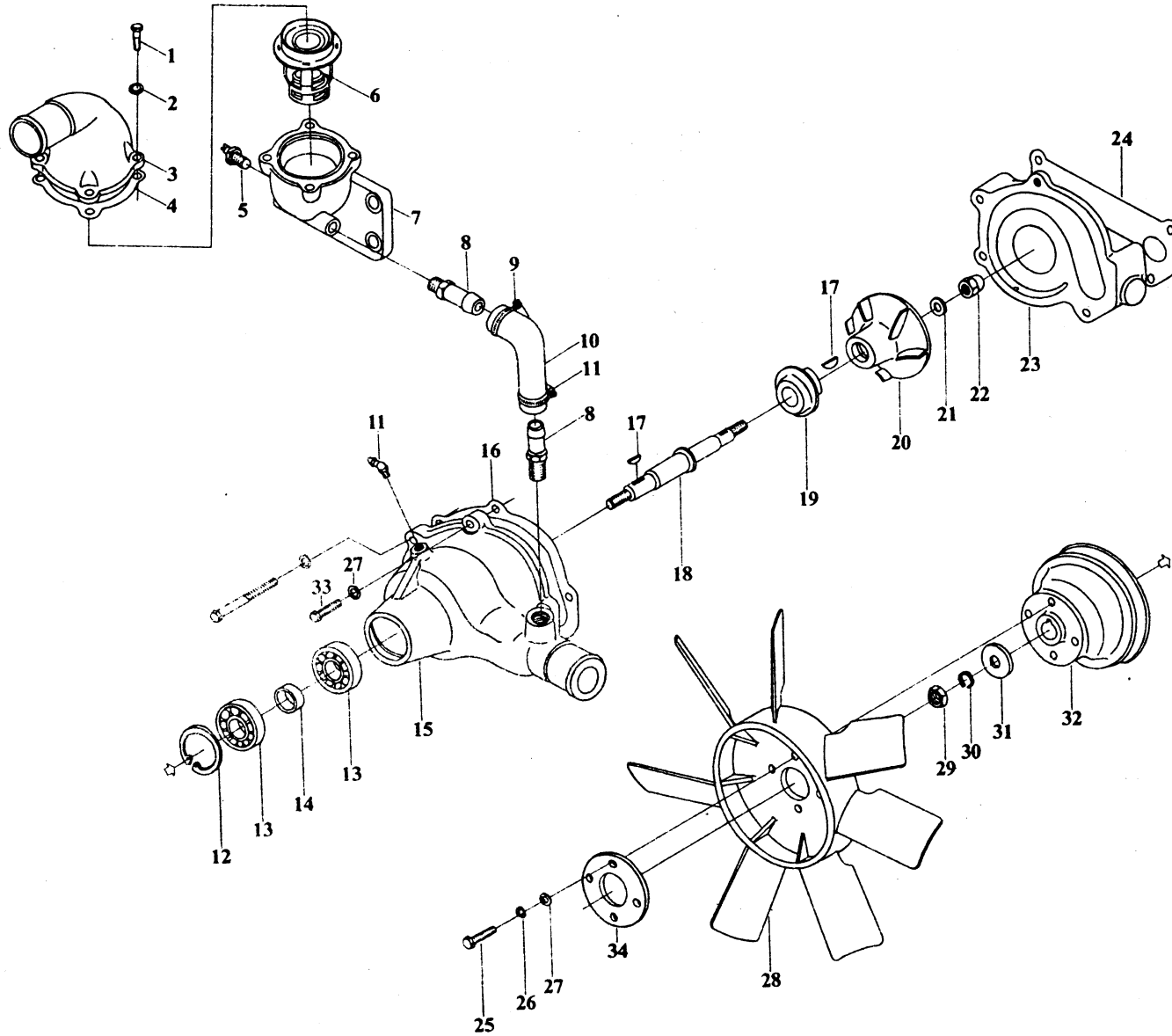

### 14.冷却系统总成(480, 380, 280) Cooling System Assy (480, 380, 280)

序号 Ser No	图号 Parts No	名称	Name of Parts	数量 Qty	附注 Remarks
1	GB5783-86	螺栓 M6×20	Bolt M6×20	4	
2	GB848-85	垫圈 6-140HV	Washer 6-140HV	4	
3	480G-11301	节温器盖	Thermostat cover	1	
4	480G-11302	节温器盖垫片	Thermostat cover gasket	1	
5		水温感应塞 (360 型)	Water temperature induction plug (Model 360)	1	与 CA-10 通用 Interchangeable with that of the CA-10
6	480G-11303	节温器 SH130	Thermostat SH130	1	
7	480G-11304	节温器壳	Thermostat housing	1	
8	480G-11109	小循环接管	Small circulating adapter	2	
9	No.1A	螺丝喉箍 $\Phi 3/4 \sim 1 1/8$ "	Screw clip $\Phi 3/4 \sim 1 1/8$ "	2	
10	480G-11001	橡胶弯管	Rubber bent pipe	1	两层夹布橡胶 Double cloth rubber
11	GB1153-79	油杯 45° M10×1	Oil cup 45° M10×1	1	
12	GB893.1-86	挡圈 40	Check ring 40	1	
13	GB278-82	单列向心球轴承 60203	Single-row radial ball bearing 60203	2	
14	480G-11104	轴承隔圈	Bearing spacer	1	
15	480G-11103	水泵壳体	Water pump housing	1	
16	480G-11107	水泵垫片	Water pump gasket	1	
17	GB1099-79	半圆键 4×6.5×16	Semicircular key 4×6.5×16	2	
18	480G-11106	水泵轴	Water pump shaft	1	
19	IIF-15 型	陶瓷石墨水封	Ceramic graphite water seal	1	

序号 Ser No	图号 Parts No	名称 Name of Parts	数量 Qty	附注 Remarks
20	480G-11105	水泵叶轮	1	
21	480G-11110	铜垫圈	1	
22	GB923-88	盖形螺母 M10	1	
23	480G-11108	水泵后盖	1	
24	480G-11107	水泵垫片	1	
25	GB5783-86	螺栓 M8×20	4	
26	GB859-87	垫圈 8	4	
27	GB848-85	垫圈 8-140HV	5	
28	480G-11200	风扇部件	1	
29	GB6170-86	螺母 M10	1	
30	GB859-87	垫圈 10	1	
31	480G-11101	垫圈	1	
32	480G-11102	水泵皮带轮	1	
33	GB5783-86	螺栓 M8×30	1	
34	480G-11003	风扇压板	1	

# 15.电气系统总成(480, 380, 280) Electric System Assy(480, 380, 280)

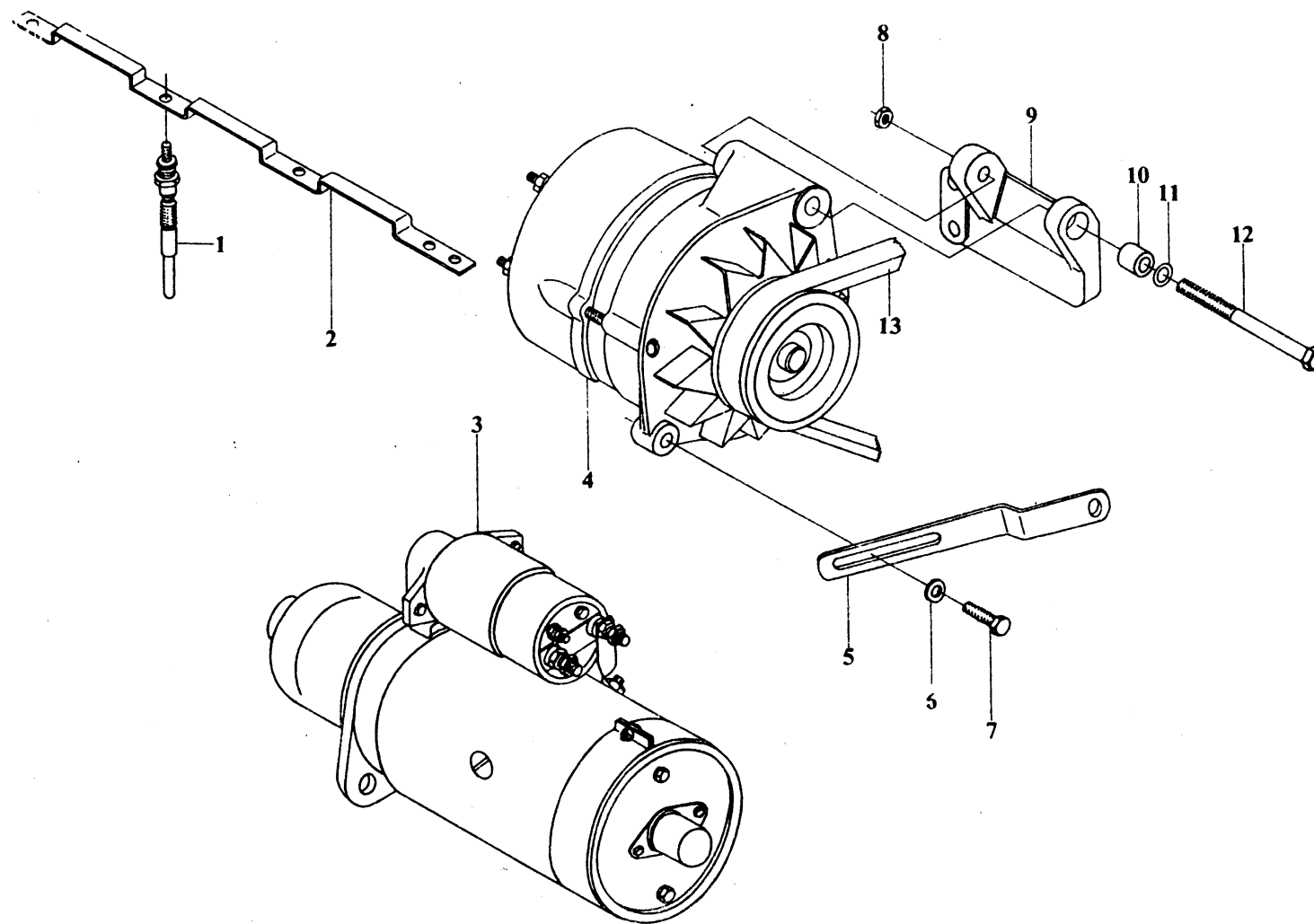



15.电气系统总成(480, 380, 280) Electric System Assy(480, 380, 280)

序号 Ser No	图号 Parts No	名称 Name of Parts	数量 Qty			附注 Remarks
			480	380	280	
1	480G-12200	电热塞部件 Glow plug	4	3	2	Model 1055
2	480G-12002	导电板 Current-conducting plate	1			
	380-12002	导电板 Current-conducting plate		1		
	280-12002	导电板 Current-conducting plate			1	
3	480G-12300	起动电机部件 QD1315A Starting motor unit QD1315A	1	1		
	380T-12300	起动电机部件 Starting motor unit			1	
4	480G-12100	JF-11 350W14V 交流发电机 Alternator JF-11 350W14V	1	1	1	
5	480G-12003	发电机下支撑 Alternator support (lower)	1	1	1	
6	GB848-85	垫圈 8-140HV Washer 8-140HV	1	1	1	
7	GB5783-86	螺栓 M8×20 Bolt M8×20	1	1	1	
8	GB6170-86	螺母 M10 Nut M10	1	1	1	
9	480G-12001	发电机上支撑体 Alternator support body (upper)	1	1	1	
10	480G-12004	发电机上支撑压紧套 Holddown sleeve of alternator support (upper)	1	1	1	
11	GB848-85	垫圈 10-140HV Washer 10-140HV	1	1	1	
12	GB5782-86	螺栓 M10×95 Bolt M10×95	1	1	1	
13	GB1171-74	三角胶带 A-950 V-belt A-950	1	1	1	

16.消声器总成(480, 380, 280) Silencer Assy(480, 380, 280)

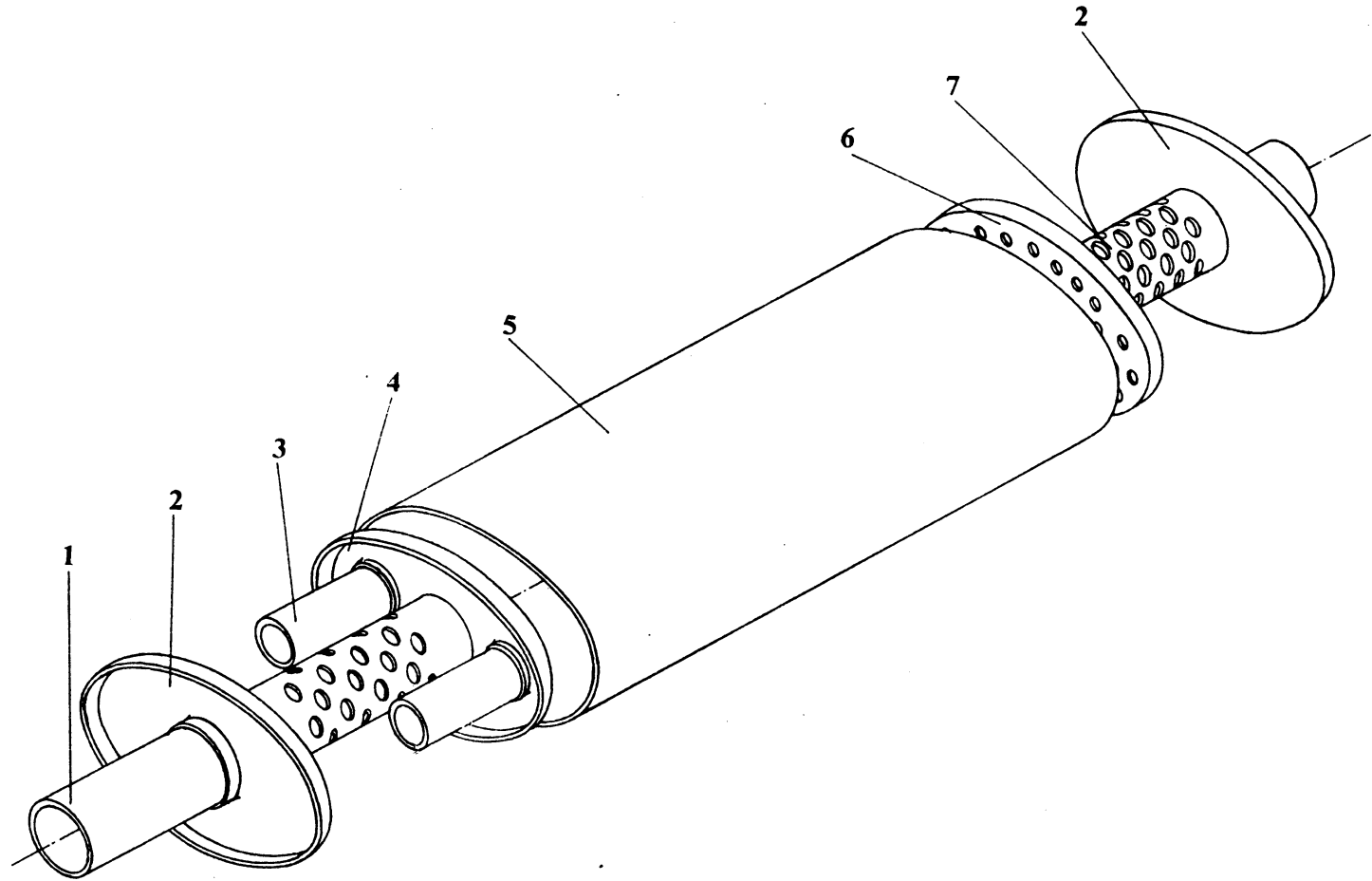

16.消声器总成(480, 380, 280) Silencer Assy(480, 380, 280)

序号 Ser No	图号 Parts No	名称 Name of Parts	数量 Qty	附注 Remarks
1	480G-13101	排气管 Exhaust pipe	1	
2	480G-13001	盖板 Cover plate	2	
3	480G-13102	中心管 Center pipe	2	
4	480G-13103	隔板 Spacer plate	1	
5	480G-13002	壳体 Housing	1	
6	480G-13201	穿孔板 Punched plate	1	
7	480G-13202	进气管 Intake pipe	1	

17. 随机工具总成(480, 380, 280) Tools Supplied with the Engine(480, 380, 280)

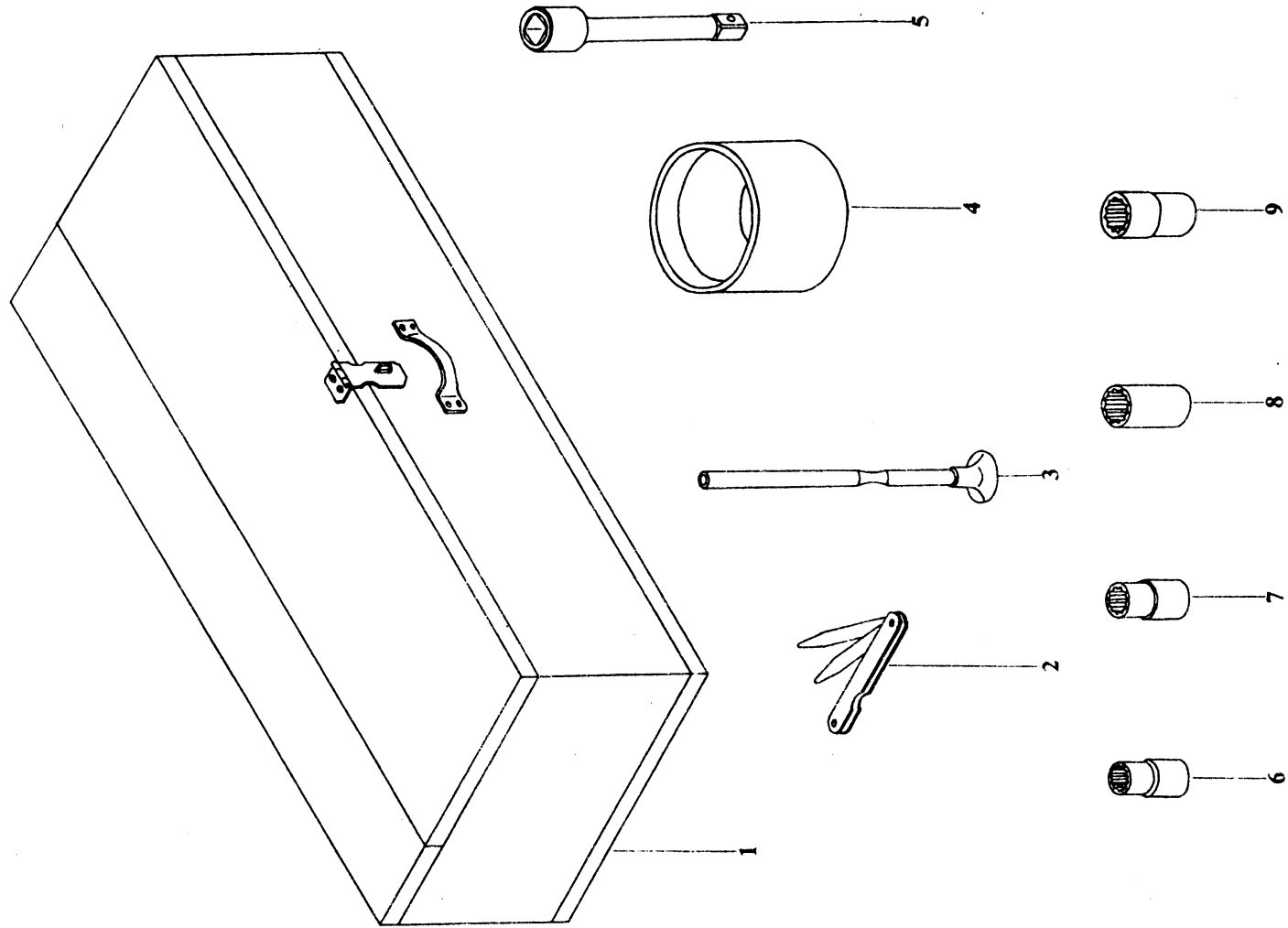

17.随机工具总成(480, 380, 280) Tools Supplied with the Engine(480, 380, 280)

序号 Ser No	图号 Parts No	名称 Name of Parts	数量 Qty	附注 Remarks
1	480G-14007	内销随机工具箱	1	
2	480G-14100	气门塞尺部件	1	
3	480G-14200	磨气门皮碗部件	1	
4	480G-14001	装活塞工具	1	
5	480G-14002	方榫套筒接杆	1	
6	480G-14003	套筒头(13)	1	
7	480G-14004	套筒头(16)	1	
8	480G-14005	套筒头(18)	1	
9	480G-14006	套筒头(21)	1	