



**SERIES Y90 DIESEL ENGINE**  
**OPERATION & MAINTENANCE MANUAL**

**YANGDONG CO., LTD.**  
**THE PEOPLE'S REPUBLIC OF CHINA**

# **FOREWORD**

**Series Y90 multi-cylinder diesel engines are ideal power units for light vehicle, agromotor, small tractor, air conditioner in bus, generator set and engineering machinery.**

**The normal and reliable operation and long service life of the engine depend not only on the manufacturing quality, but also on the reasonable operation and correct maintenance.**

**In order to provide the detailed description and instruction of this engine for operators to manipulate it correctly in short time, we offer this manual which briefly describes the performance of series Y90 diesel engines to operators, maintenance workers and relevant managers.**

**Since the construction of this engine is subject to frequent improvement and development during production and practice, it is possible that the engine supplied is somewhere not exactly the same as one described herein. Please pay attention to that when reading the manual.**

# Warning Notice

**1.It is strictly forbidden to use inferior and dirty diesel fuel or lube oil. Please choose to use fuel and lube oil with stipulated number according to the instruction.**

**2.It is strictly forbidden to leak out from an intake system(air filters,pipelines and connecting components).**

**3.It is strictly forbidden to have hard water(well water or sopping water)as cooling water.If necessary to apply the hard(water),soften it first.**

**4.It is strictly forbidden to start under the circumstances of lack of lube oil or water.**

**5.It is strictly forbidden to operate at overload or under other conditions against the rules.**

**6.It is strictly forbidden to regulate the fuel injection pump at will.**

**7.It is strictly forbidden to change the diameter of the pulley.**

**8.To control the starting time(less than 15 seconds) and the starting interval (more than 2 minutes) strictly.**

**9. It's a must to maintain the diesel engine technically in the allotted time.**

**10.Unskilled workers are not allowed to dismantle and assemble the engine and its spare parts.**

# CONTENTS

- I . Configuration and Installation Dimensions of Model YSD490Q Diesel Engine ..... I
- II .Performance Curves of Model YSD490Q Diesel Engine ..... II

## **SECTION 1. DIESEL ENGINE SPECIFICATIONS AND TECHNICAL DATA**

- I . Specifications of diesel engines ..... 1-1
- II . Specifications of the main accessories..... 1-2
- III . Main technical data of diesel engines ..... 1-3
- IV . Fit clearance and wear limit of main parts ..... 1- 4

## **SECTION 2. OPERATION**

- I . Fuel oil,lube oil and cooling water ..... 2-1
- II . Preparation before starting ..... 2-2
- III . Starting ..... 2-2
- IV . Operating ..... 2-3
- V . Stopping ..... 2-3

## **SECTION 3. MAINTENANCE**

- I . Routine maintenance ..... 3-1
- II . Maintenance after every 100 accumulated operating hours ..... 3-1
- III . Maintenance after every 500 accumulated operating hours ..... 3-2
- IV . Preservation and storage of engine ..... 3-3

## **SECTION 4. ENGINE ADJUSTMENT**

- I . Adjustment of valve lash ..... 4-1
- II . Adjustment of injection timing ..... 4-1
- III .Adjustment of injector ..... 4-2
- IV .Adjustment of lube oil pressure ..... 4-4
- V . Adjustment of injection pump ..... 4-4
- VI . Adjustment of decompression arm lash ..... 4-4

## **SECTION 5. CONSTRUCTION OF DIESEL ENGINE**

- I . Cylinder head ..... 5-1
- II . Cylinder block ..... 5-2
- III . Piston and connecting rod ..... 5-3
- IV . Crankshaft and flywheel ..... 5-5

V . Camshaft	5-5
VI . Gear transmission system	5-6
VII . Fuel and governing system	5-7
VIII . Lubricating system	5-8
IX . Cooling system	5-10
X . Electric system	5-11

## **SECTION 6. FAULTS AND REMEDIES FOR DIESEL ENGINE**

I . Hard or refuse to start	6-1
II . Power insufficiency	6-1
III . Smoking exhaust	6-2
IV . Knocking noise in engine	6-2
V . Lube oil insufficiency or no pressure	6-2
VI . Overheating of engine	6-3
VII . Engine running-away	6-3



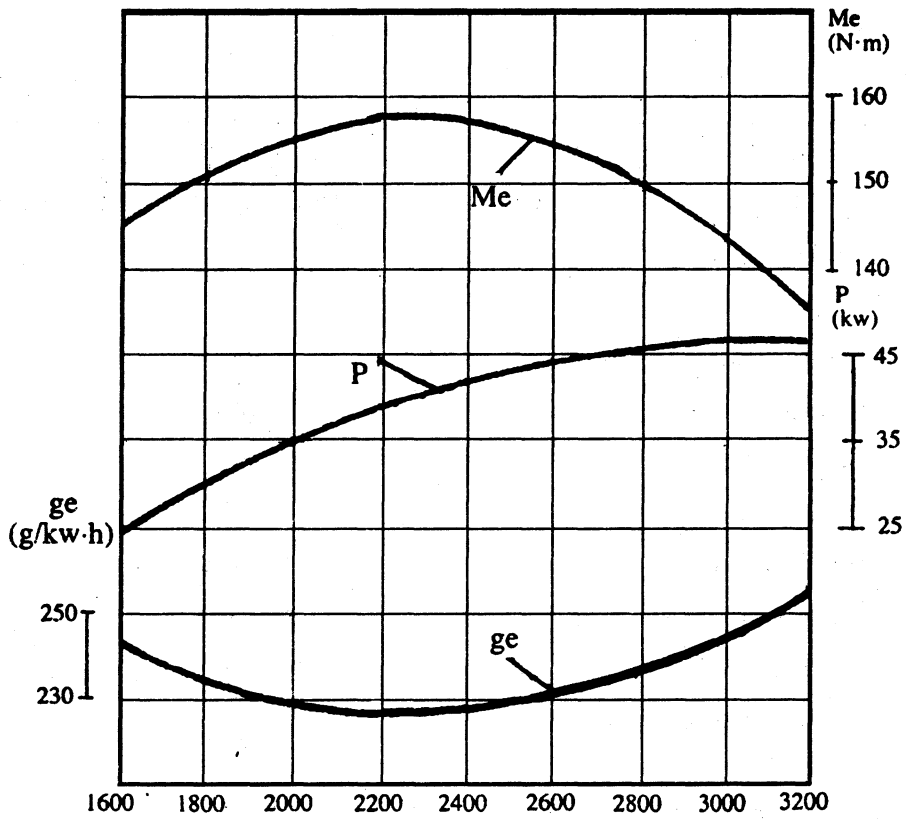

II. Performance Curves of Model YSD490Q Diesel Engine

# SECTION 1. DIESEL ENGINE SPECTFICATIONS AND TECHNICAL DATA

## I .Specifications of Diesel Engines (see Table 1)

**Table 1**

Model	YSD490Q	
Type	Vertical, water cooled, four- stroke.direct combustion chamber	
Number of cylinder	4	
Bore(mm)	90	
Stroke(mm)	100	
Compression ratio	18	
Total displacement(L)	2.54	
Firing order	1-3-4-2	
Rated power(kW)	37.0~45.6	
Rated speed(r/min)	2600~3200	
Max Torque(N m)	$\geq 149.3$	
Min Specific fuel consumption at full load (g/kW.h)	$\leq 235.3$	
Oil- fuel consumption ratio(%)	$\leq 0.8$	
Advance Injection Angle/Speed (Before TDC) (°)(rpm)	$15 \pm 1 / 2800$ With Advance Device	$18 \pm 1 / 2600$
Specific lube oil consumption(g/kw.h)	2.72	
Direction of crankshaft rotation (facing to flywheel)	Counterclockwise	
Cooling method	Forced water cooling	
Lubricating method	Pressure and splash lubrication	
Starting method	Electric	
Net mass(kg)	230	
Overall dimensions (L×W×H)(mm)	716×530×670	



## II. Specification of Main Accessories(see Table 2)

Table 2

№	Designation		Specification
			YSD490Q
1	Fuel injection pump	Type	Series I or BQ pump
		Governor	all-speed, mechanical centrifugal
		Plunger diameter(mm)	8
		Fuel delivery pump	Single-acting piston-type
2	Fuel injector	Model	P46
		Nozzle set	ZCK154-S427 or CN-DLLA154S427
		Diameter of nozzle hole(mm)	4 holes, $\phi$ 0.27
		Injection pressure(Mpa)	$19.6^{+1}_0$
3	Lube pump	Type	Rotor type
		Speed(r/min)	1500
		Capacity(L/min)	26.9
		Pressure(kpa)	400
4	Water pump	Type	Centrifugal, volute, single-suction
		Speed(r/min)	4000
		Capacity(L/min)	220
		Lift(m)	9
5	Starting motor	Type	Series DC motor
		Model	QD1315A,D138Y
		Voltage(V)	12
		Power(kw)	2.5
6	Dynamo	Type	Silicon rectifying shunt dynamo
		Model	JF11A
		Power(W)	350
		Voltage(V)	14
7	Fuel filter	Type	Single stage,paper element
		Model	C0708A
8	Lube oil filter	Type	Single stage,paper element
		Model	J0801H
9	Air filter	Type	Oil-immersed
		Model	CN212
10	Electrothermic plug	Type	Shroded
		Model	No accessory

### III. Main technical Data of Diesel Engine

#### 1. Valve lash(mm)

Intake valve(cold) 0.30~ 0.35

Exhaust valve(cold) 0.35~ 0.40

#### 2. sinkage of valve(mm) 0.7~ 0.9

#### 3. Torque limits of main bolts and nuts(N · m)

Cylinder head bolts 125~ 145

Main bearing cap bolts 140~ 160

Connecting rod bolts 100~ 120

Flywheel bolts 100~ 120

#### 4. Temperature and pressure limits

##### (1) Exhaust temperature(°C )

$n \geq 3200\text{rpm}$   $t \leq 620$

$3200\text{rpm} > n > 2600\text{rpm}$   $t \leq 600$

$n \leq 2600\text{rpm}$   $t \leq 550$

##### (2) Lube oil temperature(°C ) $\leq 100$

##### (3) Lube oil pressure in Main Passage(Mpa)

At normal operation 0.2~ 0.45

At min. Steady Speed  $\geq 0.05$

#### 5. Governor Characteristics

Min. idling steady Speed  $\leq 900\text{rpm}$

Steady regulation 5% ~ 10%

#### IV .Fit Clearance and Wear Limit of Main Parts(see Table 3)

Table 3

No	Designation	Assemlly limit (mm)	Wear limit (mm)
1	Connecting rod journal and connecting rod bushing	0.060-0.172	0.25
2	Piston pin and connecting rod small end bushing	0.025-0.050	0.10
3	Piston skirt and cylinder liner	0.130-0.195	0.40
4	Side clearance between the 1st ring and its groove	0.070-0.102	0.20
5	Side clearance between the 2nd ring its groove	0.050-0.082	0.15
6	Side clearance between the oil scraper ring and its groove	0.030-0.062	0.15
7	Gap of the 1st ring	0.300-0.450	
8	Gap of the 2nd ring and oil scraper ring	0.300-0.450	
9	Crankshaft main journal and main bearing	0.070-0.149	0.25
10	Camshaft journal and bushing	0.025-0.114	0.18
11	Idle gear shaft journal and bushing	0.025-0.075	0.18
12	Intake valve stem and valve guide	0.025-0.077	0.15
13	Exhaust valve stem and valve guide	0.040-0.092	0.15
14	Rocker arm shaft and bushing	0.016-0.061	0.20
15	Axial clearance of crankshaft	0.075-0.265	
16	Axial clearance of camshaft	0.080-0.250	

## **SECTION2. OPERATION**

### **I . Fuel Oil ,Lube Oil and Cooling Water**

#### **1.Fuel oil**

Users can select the proper grade of fuel oil according to the local ambient temperature. In the general area in China, the grade of fuel oil is according to the standard GB252 light diesel fuel. Use grade "0" light diesel fuel in summer, while in winter, use grade "— 10" light diesel fuel. Before being filled into the engine fuel tank, the diesel fuel must be settled for a long period (normally at least 48 h). Then draw out the upper part. The fuel should be filtered by silk cloth while filling it into the engine fuel tank. It will extend service life of injectors and injection pumps by using the well settle diesel fuel.

#### **2.Lube oil**

In the general area in China, users can select the proper grade according to GB/T11122 Lube Oil of Diesel Engine. Use grade CD40 lube oil in summer, while in winter use grade CD30 lube oil. When being filled into the engine oil tank, the oil should be filtered by screen.

#### **3.Cooling water**

It is recommended to use soft water such as rain water, city tap water, or clean river water for engine cooling. Well water or tap water from well water could not be used. Cooling water containing too much minerals will form water scall in an engine cooling system, affecting the engine cooling efficiency and giving rise to engine troubles.

Hard water (well or spring water, etc.) should be softened before being used. There are two softening methods;

(1) Boiling up the hard water;

(2) Adding 20g caustic soda (sodium hydroxide) to each 30L hard water to make up a solution.

When the engine operates in cold weather where the cooling water is liable to freeze, anti — freezer can be added to the cooling water to prevent it from freezing. Glycol or alcohol aqueous solution is most ordinary.

If it is difficult to start the engine under lower ambient temperature, heat the water to about 80°C before filling it into the cooling system.

## **II .Preparation before Starting**

1.Check the tightness and reliability of all connecting parts. Check control levers (speed control lever and stopping lever) to see whether they can be moved freely.

2.Rotate the crankshaft several turns,be sure that all moving parts move freely.

3.Check the oil level in the oil sump and injection pump to see whether it is kept within two marks on the dipsticks.Make sure that the fuel tank has sufficient fuel and that the fuel pipelines are unblocked.

4.Open the fuel tank cock..Check whether there is air in the fuel system. If necessary,loosen the vent screws on the fuel filter and injection pump,operate the priming pump on the fuel delivery pump by hand until the fuel flows out of these screws without bubbles,and retighten the vent screws.After that,loosen the union nuts of injection pipes on the injectors and rotate the crankshaft to bleed air from injection pipes,then retighten the union nuts.Check all fittings of the fuel system to see whether there is any leakage at all joints.

5.Check the radiator to see whether it is filled fully with water and whether there is any leakage at all joints.

6.Check the accessories to see whether they are firmly and reliably connected.Check the electrical system to see whether the battery is fully charged,all wirings are correct and all connections are tightened.

7.Check the clutch to see whether it has disengaged.

## **III . Starting**

1.Set the speed control lever at the middle speed position.

2.Turn the ignition switch to "preheating" position to heat the electrothermic plug for 20~30s.

3.Turn the ignition switch to "on" position.Press the starting button to start the engine.If it fails to start,release the button immediately.Wait 2minutes 3 minutes,before starting the engine again.If the engine fails to start after 3 attempts,check the cause and remedy the fault.

4.As soon as the engine has been started,release the press button immediately.Then turn the ignition switch to another position to charge the battery. At the same time move the fuel control lever until the engine runs at idling speed.Check the operation condition of the engine to see whether there is any abnormal noise.Especially pay close attention to the readings of oil pressure gauge,which should be within specified pressure limits.Then warm the engine up with engine speed gradually increasing to 1800~ 2000r/min

#### **IV . Operating**

1.Do not load the engine until the cooling water temperature is over 50°C and the lube oil temperature is over 40°C . The engine should not be operated undrer rated operated under rated output before the outlet water temperature reaches approximately 80°C .

2.Increase or decrease the engine load and speed gradually and evenly.In normal case,do not load and unload the engine suddenly.

3.During operation,observe the gauges on the instrument panel frequently where the readings should be within the specified limits.Pay close attention to the exhaust gas color and the operating noise.If there is any fault,stop the engine and inspect it.

#### **V . Stopping**

1.Before stopping,take off the load and reduce the engine speed gradually.Let it run at idling speed for a few minutes.Do not stop engine until the outlet water temperature falls to below 70°C .

2.After stopping the engine, the ignition switch should be turned to the middle position.

3.In winter,when ambient temperature falls to bellow 5°C ,after the engine stops and the cooling water temperature falls to below 60°C ,open all drain cocks on the cylinder block and radiator to drain off all water remnant within the cooling system,in order to avoid damages of parts due to freezing.If anti — freezer is added to the cooling water,it is not necessary to drain off.

## **SECTION3. MAINTENANCE**

For reliable engine operation with less wear and longer service life,all maintenance work must be carried out as follows.

### **I . Routine Maintenance**

1.Check the oil level in the oil sump and it should be between two marks on the dipstick and near the upper one.For a new engine or the engine reused after stopping for a long period,the lube oil must be filled to the upper mark,and operate the engine at lower speed for 5~ 10min, then stop the engine and measure the lube oil level once again.

2.Check the cooling water level in the radiator.

3.Check the lube oil level in the governor of the injection pump,replenish the oil to the specified level if needed.

4.Eliminate oil,water and gas leakags of the engine.

5.Check tightness and correctness of all components attached to the engine.

6.Check tightness and reliability of engine foundation bolts and the connection between the engine and the dirven machinery.

7.Keep the engine clean.Oil,water and dust gathered on the engine surface should be wiped away with a dry rag or cloth dipped in gasoline.Especially keep the electric equipment clean and dry and clean out the dust on the fins of the radiator.

8.For the new engine,after 50h trial running,renew the lube oil in the oil sump,fuel injection pump and governor,and flush the oil filter element,oil sump and oil strainer.

9.Promptly eliminate the troubles and faults found.

### **II .Maintenance after Every 100 Accumulated Operating Hours**

Besides the " routine maintenance" work,and the following items:

1.Renew the oil in the sump.

2.Clean the oil filter or renew the paper element if necessary.

3.Clean the fuel filter or renew the paper element if necessary.(It may as well be replaced after every 200 accumulated operating hours.)

4.Clean the oil filter or renew the paper element if necessary.

5.Clean the valve lashes,readjust them according to the recommended procedure if necessary.

6. Check the tension of the fan belt, and readjust it if necessary.

7. Fill the nipple of cooling water pump bearing with ZG-4 calcium-based grease with a grease gun.

8. Clean out the dust in intake manifold, clean the inside of the air cleaner, brush off the dust gathered on the paper element surface, and clean the inside of the exhaust manifold and silencer.

9. After every 200 accumulated operating hours, check the injection pressure and spray pattern of injection. If necessary, dismantle the injector, clean the nozzle set, and readjust the injection pressure.

10. Check the voltage of battery and the specific gravity of battery acid, which should be within 1.27~1.28 (at ambient temperature of 20°C). When it is less than 1.14, the battery should be recharged. The level of battery acid should be 10~15mm above the pole plate. If insufficient, add distilled water to the required level.

11. All parts dismantled for maintenance should be washed, and cleaned and correctly reassembled. After reassembly, start the engine and check whether it is in proper operation. All faults should be remedied.

### **III .Maintenance after Every 500 Accumulated Operating**

Besides the work of maintenance after every 100 accumulated operating hours, the following items are needed:

1. Check the injection pressure and spray pattern of the injector. If necessary, dismantle the injector, clean the nozzle set and readjust the injection pressure.

2. Check fuel delivery of the injection pump, and recalibrate it on a test bench if possible. Check the injection timing, and readjust it if necessary.

3. Check the sealing of the intake and exhaust valves. If necessary, grind and lap the valve seats and readjust the valve lashes.

4. Check the tightness of the connecting rod main bearing cap and flywheel bolts.

5. Retighten the cylinder head bolts and adjust the valve lashes according to directions given in section 4.

6. Clean or replace the paper element of air cleaner.

7. Clean the cooling system. The cleaning solution can be prepared by adding 150 grams of caustic soda (NaOH) to every litre of water. Before cleaning, drain the system completely and then fill in the same capacity with cleaning solution. Let it remain in the system for 8~12h. Then start the engine and run it until the temperature of cleaning solution reaches normal operating temperature. Stop the engine and drain the system immediately in order to avoid settling of scale within the system. Finally, flush the system with clean water until all sediment is flushed out.



8. Check whether the thermostat is in good order. Examine the water dropping out from a weep hole of the water pump. It is necessary to renew the water seal, if flowing out too much of water.

9. Check the wiring contacts of the electric equipment to see whether they are connected firmly and well. Burnt marks should be removed.

10. After every 1,000 accumulated operating hours, add the following items;

(1) Make an overall check on all parts and components. Make necessary adjustments and repairs.

(2) Dismantle the dynamo and starting motor. Clean out the dirty grease in the bearings and refill them with clean grease. Check the pinion of starting motor.

11. After every 1,500 accumulated operating hours, add the following items:

(1) Remove the cylinder head, check the valve and valve seats and other parts of cylinder head assembly.

(2) Remove the carbon deposits on the surfaces of cylinder head, liner, piston and piston ring, etc., and wash down them.

(3) Check and measure wear of the pistons and piston rings.

(4) Check and measure wear of the cylinder liner.

(5) Check and measure wear of the crankshaft main journals and crank pins. Clean lube oil passages of the crankshaft.

(6) Check wear of the main bearing and connecting-rod bearing shells.

(7) Clean oil passages of the cylinder block and replace lube oil.

#### **IV .Preservation and Storage of Engine**

If the engine is to be put out of service for a comparatively long period of time, it is necessary to preserve it according to the following procedure:

1. After the engine stops and still does not cool yet, drain out completely the lube oil, cold water and fuel immediately. Clean the oil sump and oil strainer.

2. Clear out the dust and oil on the engine surface. With antirust oil smear all the unpainted exposed surfaces of engine except rubber and plastic parts.

3. Heat the filtered lube oil to 110~120°C ,until all bubbles in the surface of oil disappear. Then pour the dehydrated oil into the oil sump until oil level reaches the upper mark, and turn the engine, in order to make sure that the lube system is completely filled up with this oil.

4. Pour some dehydrated oil into cylinder through injector — assembled holes on the cylinder head, and turn the crankshaft to make sure that the piston, piston ring, cylinder liner and valve seat are all covered with a layer of this oil.

5. Block the outlets of intake and exhaust manifolds (silencer) with wooden plugs or wrap up properly with plastic film in order to prevent any dust from getting in.

6. The engine should be stored in a clean room with good ventilation and low humidity. The engine should be covered. Chemicals near it are strictly prohibited.

The preservation according to the above procedure may be valid for 3 months. Over this period, repeat the procedure.

## SECTION.4 ENGINE ADJUSTMENT

### I . Adjustment of Valve Lash

When the engine is maintained and repaired, it is necessary to check and adjust the valve lashes. The recommended method of adjusting the valve system and valve lash is as follows:

1. Remove the cylinder head cover. Check and tighten the nuts fastening the rocker arm shaft stands.

2. Turn the crankshaft to make sure that the piston of 1st cylinder is at the compression TDC position. The timing mark on the inspection window of the flywheel housing exactly points to the " o" mark on the flywheel rim ,or the " o" mark on the crankshaft pulley is aligned with the pointer on the cover of timing gear housing.

3. slip a feeler gauge between the rocker arm and the tip of the intake or exhaust valve stems of the 1st cylinder respectively to check and adjust the valve lashes. Intake valve lash and exhaust valve lash in cold must be the value specified in section 1. Then after turning the crankshaft by 180° to adjust the valve lash of other cylinders according to the engine firing order (1- 3- 4-2) for the four cylinder engine and 1-3-2 for three cylinder engine.

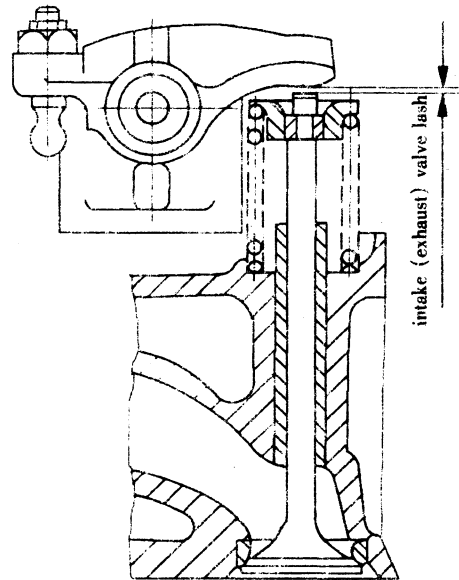

Fig. 1 Adjustment of valve lashes

### II . Adjustment of Injection Timing

To obtain the most economical specific fuel consumption and to ensure normal operation of the engine, injection timing should be adjusted properly. For the Model 485 diesel engines, the angle at which injection begins should be the value specified in section 1 .

The adjusting method of injection timing is as follows:

1. Vent the air trapped in the fuel system, and turn the crankshaft to fill up the injection pump with fuel. Disconnect the injection pipe of the 1st cylinder, turn the crankshaft slowly in the direction of its rotation and at the same time observe the fuel level in the hole of fuel pipe union. When this fuel level just starts to rise, stop turn the crankshaft immediately.

2. Check the timing mark on the inspection window of flywheel housing to see whether it aligns with the correct graduated mark of specified advanced injection angle on the flywheel rim (or on the crankshaft pulley).

3. In case that they do not match with each other, the advanced injection angle can be adjusted by removing off the front cover on the timing gear housing and loosening the three screws fastening the injection pump timing gear support (see fig.2). If the injection timing is too advanced, turn the timing gear support anticlockwise to the proper angle. Otherwise, turn the support clockwise. If adjusting range is not enough due to limitation of the three elongated holes, loosen a little the three fastening nuts on the triangular flange of the injection pump and turn the injection pump. Facing the front end of engines, when the injection pump rotates clockwise, the fuel injection will retard; while the pump rotates anticlockwise, the fuel injection will advance.

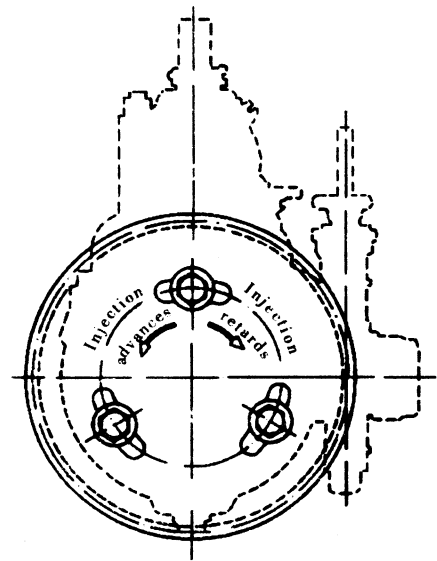

**Fig. 2 Adjustment of specified advanced injection angle**

4. Additionally, if the engine has injection angle advance device, the advanced injection angle can be adjusted by loosening the three nuts on the triangular flange of injection pump and turn the injection pump shaft. Facing the front end of engines, when the injection pump rotates clockwise, the fuel injection will retard; while the pump rotates anticlockwise, the fuel injection will advance. After turn the injection pump once, it is must to tighten the three nuts and check the advance injection angle again until the advance injection angle fits the specified value.

### **III. Adjustment of Injector**

Injector test and adjustment must be performed on a injector tester in order to adjust injecting pressure, inspect spray pattern and remedy faults.

Too high or too lower injector injecting pressure, and abnormal spray on damaged injector parts will cause engine troubles, such as black smoking, power and speed dropping, increasing exhaust temperature and diesel knocking, etc. Generally, the "shut off" method is recommended to

check a faulty injector, i.e. loosen the nuts of injection pipe from the injector of every cylinder successively, and observe the exhaust smoke. When the cylinder with the faulty injector stops firing, black smoke would disappear and engine speed is not appreciably affected or not affected at all. It may also be checked by listening to the chattering action of the injector of every cylinder with the flywheel rotating. If the distinct clear sharp sound of certain cylinder could not be heard, the injector in this cylinder may be faulty.

#### 1. Procedure of injector testing and adjustment

(1) Work the injector tester hand pump until the gauge pressure reaches about specified injection pressure. Then operate the hand pump slowly and adjust the injection pressure at which injection begins. The nozzle should not show any signs of leakage. If fuel drips around the nozzle tip after several tests, the nozzle set must be dismantled for cleaning and grinding. Then test it again.

(2) Remove the lock nut, turn the adjusting screw to get the pressure at the beginning of injection which should be specified value in section 1. Then tighten the lock nut, and test it again.

(3) Work the hand pump at a rate of approximately 1 stroke per second and observe the nozzle spray. The fuel spray should be even, and well atomized in a shape of cone. At any cross section of the cone, the atomized fuel should be finely and evenly distributed. Fuel droplets and irregular pattern which can be seen by naked eyes should not be present in the spray. There should be a distinct clear sharp sound at the end of injection. Generally, irregular pattern of the spray is caused by needle valve seizure, fuel dripping is generated by damaged conical sealing surface of needle valve and spray split results from carbon deposits on the tip of nozzle and its heat deformation.

#### 2. Injector dismantlement and repair

(1) Before dismantling the injector, clean off the dirt gathered on it. Clamp the nozzle body in a vice lined by copper sheets on its jaw with the nozzle upward. Turn off the nozzle cap nut and take out the nozzle set. Draw out the needle valve from the nozzle body and soak it in clean fuel oil. Then clamp the injector in the vice upside down again. Dismantle the adjusting nut, and adjusting screw, then take out the injector spring and spindle.

(2) If the nozzle set is seized or emits fuel badly, it must be cleaned. Soak the seized nozzle in fuel oil for a while, and clamp the needle valve by a pliers with cloth lined. Then rotate and draw it out slowly, just to avoid scratching its surface. Decarbonize the needle valve and nozzle body with wooden chip soaked in fuel oil. It is forbidden to clean them with metal chip. If the

guiding surface of the needle valve and nozzle body is not smooth enough, it may be lapped with a little bit of clean fuel oil, then clean off any metal particulates in clean fuel. While lapping of needle valve with nozzle body, never knock the needle valve against the body.

#### **IV . Adjustment of Lube Oil Pressure**

See fig.3. Loosen the lock nut and turn the adjusting screw with a wrench to take the lube oil pressure within 200 ~ 400kPa (in cold state the pressure may be higher slightly). After adjustment, the pressure adjusting screw must be locked by the lock nut.

#### **V . Adjustment of Injection Pump**

The injection pump has tested and calibrated at the factory. If it is necessary to readjust, the readjustment must be performed in a injection pump test bench with a standard injector and injection pipes of standard length according to the instructions in Operation Manual of the Injection Pump.

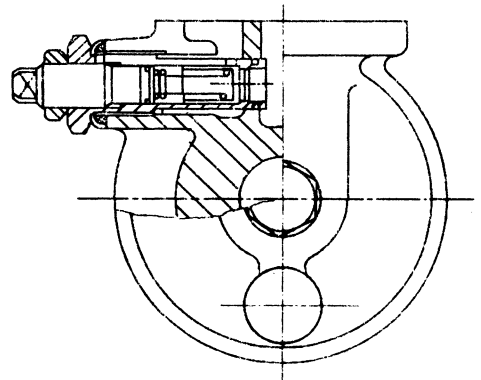

**Fig. 3 Adjustment of lube oil pressure**

#### **VI .Adjustment of Decompression Arm Lash**

Turn the crankshaft to make that the piston of 1st cylinder is at the compression T.D.C. position. Turn the decompression arm to decompression position. Loosen the lock nut. Turn the adjusting screw to bring just into contact with the lock arm of intake valve (i.e. no valve lash). Screw the adjusting screw by 3/5~4/5 turns again (make the intake valve lifting to 0.6~ 0.8mm). Then tighten the lock nut. After this, according to Item 3 of "Adjustment of Valve Lash" , make the piston of another cylinders at the compression TDC position one by one and adjust by the same method.

## SECTION 5. CONSTRUCTION OF DIESEL ENGINE

### I. Cylinder Head

When assembling, cylinder head is fixed on the cylinder block with cylinder head bolts. A torsion spanner should be used during tightening the bolts. The bolts are tightened several times in sequence shown in Fig.4 until they reach the specified torque limit. After dismantling and assembling the cylinder head, it is necessary to shut down the engine when first warming up period is over. Retighten each bolt on the cylinder head according to the specified value of torque limit and readjust the valve lashes.

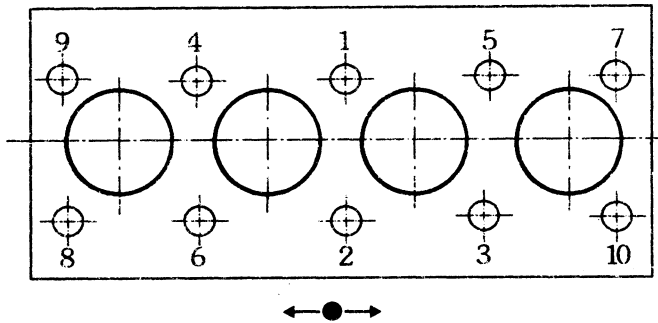

Fig. 4 Tightening sequence of cylinder head bolts

The intake and exhaust valves are made of different materials. Each couple of the valve and valve seat should be ground in order to prevent leakage.

It is necessary to grind when gas leaks out due to burning out, mechanical pitting and wear appeared on the sealing face of valve and valve seat. When grinding, apply a grinding paste (fine valve sand) on the conic sealing surface of valve. Then the valve and valve seat are lapped in pair until a even, continuous and lustreless sealing band appears. It is strictly forbidden that the grinding paste enters the valve guide. After lapping, clean the valve, valve seat and valve guide carefully. Wearing of the valve guide may cause the eccentric wear of valve sealing band which results in abnormal sealing. Pour some kerosene or diesel fuel into the gas passage, and observe whether there is any leakage, then check the valve sealing.

The sealing band of valve and valve seat is normally 1.2~1.6 mm in width. After a long period of service and regrinding many times, the width of valve sealing band may get wider, which may cause abnormal sealing. Being kept concentric with respect to the valve guide hole, the contact band on valve seat is to be refaced by a reamer. Then grind the valve and valve seat in pair.

.After service for a long period and regrinding many times, the sinkage will increase. When it exceeds 2.0mm, replacing the valve seat should be considered.

Check the valve lashes frequently. The recommended adjusting method is shown on paragraph I of Section 4.

If the lashes are too large, it may affect the correctness of valve timing and the noise level of valve device rises. On the contrary, it may cause leakage or valve burnt out.

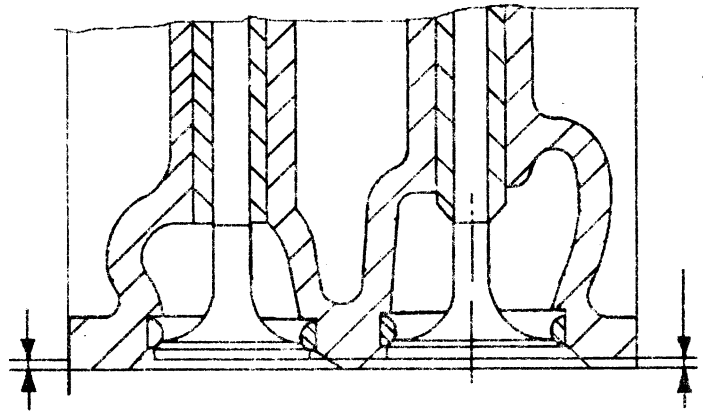

**Fig. 5 Valve sinkage**

## II . Cylinder BLock

The cylinder block is made of cast iron and is of crankshaft centerline off-split face structure. Besides the fitting bores for the liner and the cylinder head boltholes, on the top plane of the block there are holes leading water to the cylinder head. Near the rear end of the block there are channels delivering lube oil upward to the cylinder head.

The water pump is mounted on the upper front face of cylinder block, and the gear system is on the lower part. The flywheel housing is installed at

the rear face of the block. On the block bottom, there are a lube oil inlet, a hole for the lube oil pump and tap holes for installing the sump. There are a side cover and a breather on the left side of the block (facing to the front end). There are the lube oil filter, fuel filter and drain cock on the right side of this block. The main lube oil line and its branches are arranged in horizon. The lube oil passages delivering lube oil to the camshaft bushes are slant. When dismantling and repairing

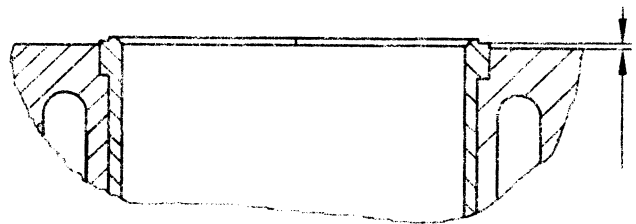

**Fig. 6 Protruding height of the liner flange plane relative to the plane of cylinder block**



the diesel engine, flush all lube oil passages, and be sure that they are clean and unlocked. All passage plugs should be sealed reliably and leakproof.

The main bearings are of complete suspension-support type. Since the main bearing caps and cylinder block are matched to bore, the matching marks are both on the block and main bearing caps. Misplacement or inverted installation, when assembling, are prohibited. The main bearing shells are made of high-tin aluminium-base alloy. When dismantling for cleaning, be sure that the upper and lower bearing shells are in right places (the upper shell with an oil groove). The crankshaft thrust plates are assembled on the last main bearing with an upper piece and a lower piece on each side. The thrust plates bear the axial force from the crankshaft. There are oil channels on its operating surface which should be located against the thrust planes on the crank, and its back surface is smooth. Never locate them in reverse. When tightening the main bearing bolts, two bolts on the bearing cap should be tightened several times in turn. Before tightening the main bearing cap, strike the crankshaft forward and backward in order to keep the upper and lower thrust plates in the same plane. Then tighten the bolts until they reach the specified tightening torque. When completing the crankshaft assembly, turn it at the flywheel end by hand to check whether it can be moved freely.

The liner is slipped into the cylinder bore vertically so that deformation of the liner may be avoided. The liner flange plane should protrude out the top plane of cylinder block by 0.07~0.15 mm to keep an excellent sealing between the cylinder liner and cylinder head, as shown in Fig 6.

### **III . Piston and Connecting-rod**

The piston and connecting-rod assembly comprises the piston, piston rings, piston pin, retaining rings, connecting-rod, connecting rod cap, connecting-rod bolts and connecting-rod bearing shells and bush, etc. The mass difference of piston and connecting-rod assemblies in the same engine should be within 20g.

All of the compression rings are made of alloy cast iron. The outer circle surface of the first ring is plated with porous chrome in order to decrease the wear between the cylinder liner and piston ring. The second ring has a conical surface. When assembling, the surface marked with a sign "up" should be kept against the top of piston and be careful to avoid assembling in reverse.

The oil-control ring is of tensioning ring type. The radial force of oil ring is still kept while decreasing the elasticity due to wear. Thus the service life of oil ring is prolonged.

Check the ring end gap before assembling the piston ring. The method measuring this gap is recommended as follows: Press down the piston ring evenly into the cylinder liner by 15~20mm from the top surface of liner. Measure the clearance with a feeler gauge. In normal case, the measuring value should be 0.2~0.4mm (Fig.7). In case the gap value is less, enlarge it by a file. If it is excess, replace it with another one. In addition, measurement should be made with a feeler (gauge) to check the side clearance between the piston ring and ring groove. The side clearance for the first ring should be 0.07~0.102mm and 0.05~0.082mm for the second ring as shown in Fig8.

When dismantling and assembling the piston ring, a special tool may be used. The ring end gap of piston rings should be set off with each other by 120 °C to prevent being in line with the piston pin seat hole.

If the piston ring is seized and could not move when checking, soak it in diesel fuel (kerosine or gasoline) for 24h or more. Then knock the piston ring slightly to make it become flexible of itself. On getting out the piston ring, clean it in diesel fuel or carbon tetrachloride.

Check the piston to see whether there is any cracks or scars. Change the defective piston and renew its rings.

The cross section of the connecting-rod is I-shaped, with the splitting surface of large end being perpendicular to the center line of connecting-rod. Boring the connecting-rod hole and connecting-rod cap must be mated. Therefore when assembling, pay close attention to the mating

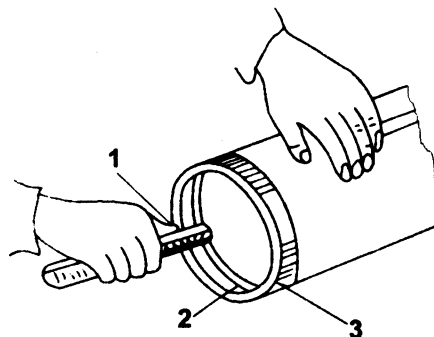

**Fig. 7 Measurement of piston ring end gap**  
**1. Thickness feeler (gauge) 2. Piston ring 3. Cylinder liner**

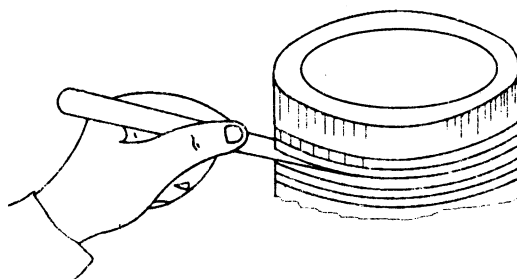

**Fig. 8 Measurement of side surface gap of piston ring**

marks on both the connecting-rod and connecting-rod cap in order to avoid making mistakes. The connecting-rod bearing shell is made of steel with high tin aluminium alloy. When the clearance between the connecting-rod bushes and crankshaft journal exceeds the specified value after wearing or severe stripping and burning occur on their surfaces, they must be renewed in pair.

During engine overhaul or renewing the connecting-rod, check the axis parallelism of the connecting-rod small end to the large end, which is specified to be within 0.01mm/100mm (both in vertical and horizontal direction). If it goes beyond the scope, alignment should be made.

Before dismantling the piston and connecting-rod assembly in cylinder liner or assembling, it is necessary to scrape and clean the carbon deposit and greasy dirt on the top part of cylinder liner. Before assembling, smear some clean oil on the cylinder liner bore, external surface of piston and piston rings, connecting-rod bearing shells and crankshaft journal. Then place the piston guide sleeve in the cylinder liner, fit the piston and connecting-rod assembly into the cylinder liner carefully, and tighten in turn the connecting-rod bolts according to the specified tightening torque limit in several separate times. After finishing the assembly, turn the crankshaft, be sure that it rotates smoothly.

#### **IV . Crankshaft and Flywheel**

The crankshaft timing gear and pulley are fitted on the front output end of crankshaft. Positioned by the locating pin, the flywheel is fitted on the rear end flange of the crankshaft with six bolts tightened according to the specified torque value. A bearing E60203, which supports the transmission shaft of gear box, is fitted on the flange center at the rear end of the crankshaft. An angular calibrating line is marked on the crankshaft pulley and a pointer, which is fitted on the cover of the timing gear housing, indicates the reading of advanced injection angle.

A flywheel gear ring is bound on the outside diameter of flywheel in shrinking fit. A calibrating line, which provides observation for advanced injection angle, is marked on the flywheel.

#### **V. Camshaft**

There is a gear driving the lube oil pump in the front of the last set of cams (facing to the front end). When the camshaft revolves, the cam on the shaft drives the tappets, push rods, valve rocker arms and valves, which respectively control the intake and exhaust valves for each cylinder.

There is a thrust flange at the front end of camshaft, and a thrust plate of camshaft is located at the front end to control the camshaft axial moving. The lube oil is delivered to the camshaft bushings separately through the main oil line. Before assembling the front bushing of camshaft, check whether the oil holes on the bushing and oil passage in the cylinder block communicate with each other. As the camshaft gear is engaged with the driven gear on the oil pump, therefore, before dismantling the camshaft, it is necessary to disassemble the lube oil pump, then draw the camshaft out from the front end.

The axis of the tappet deviates from the center line of cam width. During operating, the tappet rotates so as to provide an even wearing on the bottom surface and the cylindrical surface of tappet.

## VI . Gear Transmission System

The gear transmission system consists of the crankshaft timing gear, timing idler, camshaft timing gear, injection pump timing gear and hydraulic pump gear.

Except the hydraulic pump gear, all the timing gears are all marked with timing signs which, when assembling, should align with each other at the meshing position (the single tooth marked with a sign is inlaid between the two adjacent marked teeth) in order to ensure the movement relationship of all moving parts, as shown in Fig.9.

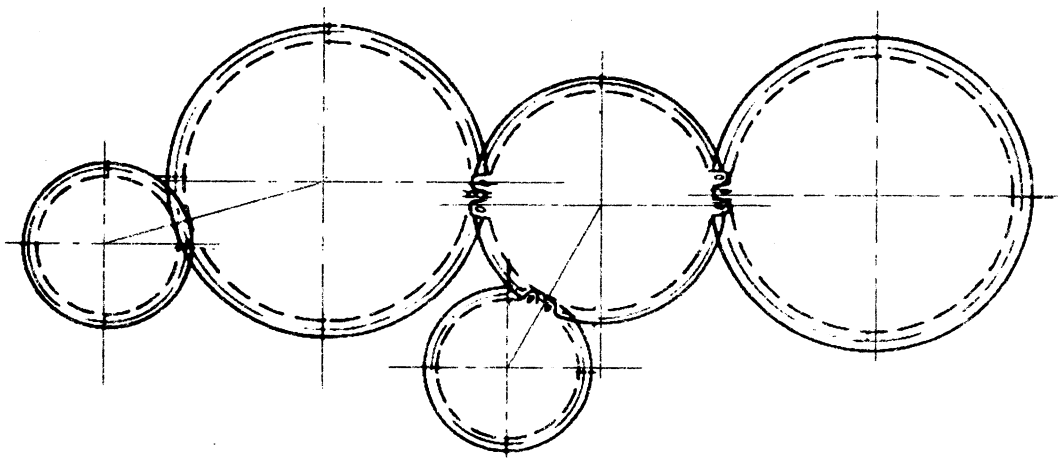

Fig.9 Timing gear meshing signs

Special tools are necessary for dismantling or assembling the crankshaft timing gear. The camshaft timing gear can be got out by two bolts M8 on the gear spoke which are turned staggeringly and evenly. The timing idler is located on the cylinder block by slide fit. The injection pump timing gear is assembled on the timing gear seat which is fixed on the camshaft of the injection pump. Whenever three bolts setting the injection pump gear are loosened, the injection pump gear can be drawn out. The injection pump gear is pushed out when the three bolts M8 × 35 are staggeringly tightened on the gear seat.

## VII. Fuel and Governing System

The fuel and governing system is the main operating section of the diesel engine. It is composed of the fuel delivery pump, fuel filter, injection pump, governor, fuel injection and fuel return pipes, etc. as shown in Fig. 10.

The fuel is pumped by the fuel delivery pump from the fuel tank into the injection pump through the fuel filter. The diesel fuel is delivered through the injection pipe under high pressure produced in the pump, and is then atomized by the injector before burning in the combustion chamber.

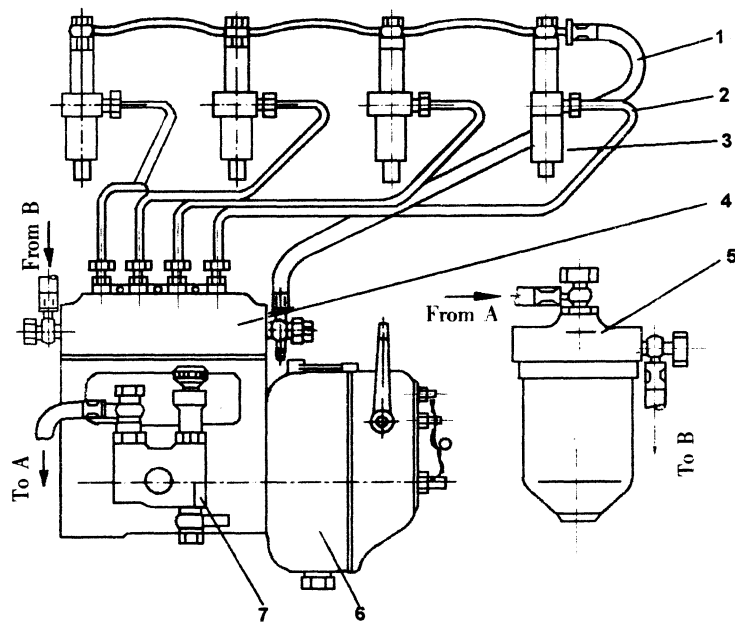

**Fig. 10 Fuel and governing system**

1. Fuel return pipe 2. Fuel injection pipe 3. Injector  
4. Injection pump 5. Fuel filter 6. Governor 7. Fuel delivery pump

The fuel delivery pump is a single-acting piston type pump located on the outside of the injection pump. The eccentric cam, which is set on the camshaft of injection pump, drives the fuel delivery pump, which finally presses the fuel into the fuel cavity in the injection pump.

The injection pump has been calibrated by the manufacturer. Be sure not to dismantle it at will. When the dismantlement, repairment and adjustment are required, it is forbidden to interchange the plugger sets and discharging valve sets, and be sure to keep clean when assembling.

The all speed mechanical- centrifugal governor is applied. The governing handle can be operated to control the speed of diesel engine. When the governing handle is turned in the direction of tightening the governing spring, the fuel supply would increase and the engine speed would be up consequently. When this fuel supply would decrease and the relevant engine speed would go down. Do not move either the high speed or the idling speed set screws or screw the maximal fuel supply set screw on the governor at will during operating.

On the governor housing, a stop handle is mounted which, if necessary, can be operated to stop the engine at emergency.

The needle valve and its body are a precise set lapped in couple, therefore, close attention is paid to that, when dismantling and assembling them. Be sure not to interchange them and to keep them clean.

### **VIII. Lubricating System**

The lubricating system is composed of the strainer, lube oil pump, oil filter and pipelines, as shown in Fig. 11.

The engine adopts pressure and splash lubrication. The pressure lubrication is applied to the main bearing, connecting-rod bearing, camshaft bushing. The cylinder sleeve, piston, piston pin, connecting-rod bushing, cam and its tappet, as well as valve and its guide are lubricated by splashed oil spray. The bearings for the water pump shaft are lubricated regularly by adding lubricating grease.

The lube oil is sucked up to the lube oil pump from the oil sump through the strainer and the oil inlet pipe, and pumped into main oil line through the oil filter. One path of the lube oil lubricates the main bearing and the connecting-rod bearing through the oil hole on the crankshaft; other path of the oil lubricates the camshaft bushing, and also the oil is supplied intermittently to the rocker arm shaft bushing through the eccentric oil channel in the rear journal of the camshaft; and the third path of the oil is fed to the timing idler bearing. The lube oil pump is of slantingly mounted type. A single stage paper cartridge oil pump is used. The filter element can be replaced regularly. In case of blocking up during operation, the oil flows into the main oil line by opening

the safety valve while the oil filter loses the function of filtration,so it is necessary for the cartridge to be cleaned or replaced regularly according to the maintenance.

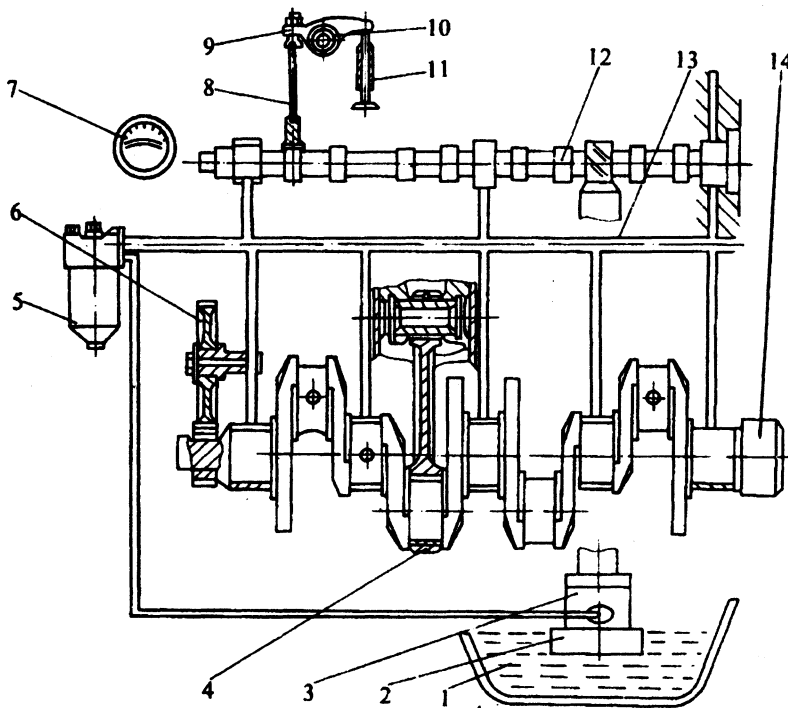

**Fig. 11 Lubricating system**

- 1. Oil sump 2. Strainer 3. Lube oil pump 4. Piston and connecting – rod assembly and cylinder liner 5. Lube oil filter 6. Gear train 7. Oil pressure gauge 8. Rocker arm 9. Valve push rod, valve tappet and block hole for tappet 10. Rocker arm shaft 11. Valve and valve guide 12. Camshaft and bushing 13. Oil lines in the block 14. Crankshaft and bearing**

## IX . Cooling System

The cooling system is a forced circular water cooled type,as shown in Fig. 12.The system consists of a radiator,water pump,cooling fan,thermostat and diversion hood,etc.

The cooling water,pumped from the radiator into the cylinder block water gallery ,flows tangentially and round to the cylinder liner,then up to the cylinder head.The hot water from the front end of cylinder head flows back into the radiator through the thermostat and outlet water pipe.When the temperature of cooling

water is below 70 C ,the thermostat closes,and the cooling water will be short-cut for circulation from the branch water pipe on the front end of the cylinder head to the water pump inlet pipe and the water pump;when the temperature of the cooling water is above 70 ~ 80 °C ,the thermostat opens,and the cooling water flows into the upper part of the radiator through the thermostat and flows downward the thermostat and flows downward along the flat- tube into the lower part of the radiator,during which the cooling water is cooled by the fan and completes the regular circulation. The cooling fan can be of either suction or blast type according to its application.

The centrifugal water pump is driven by the fan belt on the crankshaft pulley.In case of severe water dropping out from the weep hole at the lower part of the pump housing due to the damage of water seal during operation,it is necessary to replace the water seal but blocking the weep hole at the time of leakage is not permitted,or the water will enter into the bearings,which causes their quick wear.Replacement must be considered while abnormal noise occurs during operation. The grease nipple of water pump must be filled regularly with ZG- 4 calcium based grease which amounts to about 1/2 ~ 1/3 of the capacity of bearing cavity according to the maintenance.The bearing will be overheated with excessive grease. The single valve type thermostat with corrugated pipe is filled with temperature- sensitive fluid which can automatically control the valve opening and closing.

The fan belt must be checked and adjusted regularly for its tension according to the proedures for the maintenance.The slack is 10 ~ 20 mm when pressing the belt between the fan and the dynamo pulleys.

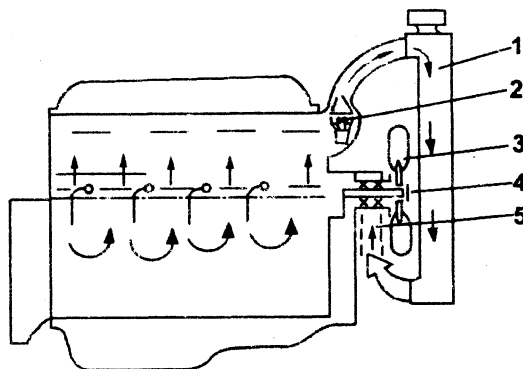

Fig. 12 Cooling system

1. Radiator
2. Thermostat
3. Cooling fan
4. Water pump
5. Inlet water pump



## X . Electric System

The electric system is composed of the battery, starting motor, dynamo, electrothermal plug, starting button and instruments, etc., as shown in Fig. 13.

The parallel excited silicon rectifying dynamo model JF11 comprises the three — phase

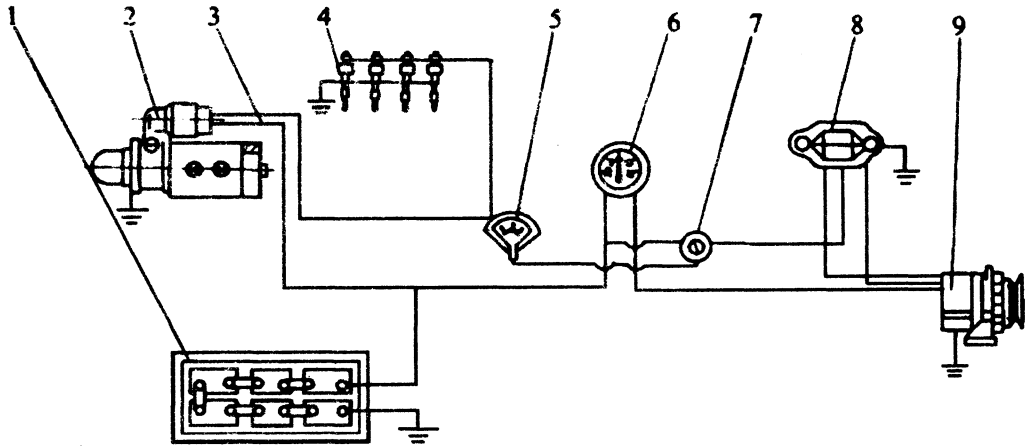

**Fig. 13 Electric system**

**1. Battery 2. Starting motor 3. Wire 4. Glow plug 5. Preheating and starting switch 6. Galvanometer 7. Ignition switch 8. Regulator 9. Dynamo**

alternator and silicon diode rectifier. Be careful that the armature must be negative pole grounded, or the dynamo will be damaged.

Refer to operation and maintenance manual for JF series silicon rectifying dynamo for the operation and maintenance of the dynamo.

After turning on the starting switch, the flywheel gear ring is engaged with the motor pinion by the solenoid, meanwhile the flywheel is driven by closing the current circuit of starting motor.

As soon as the engine is started, the starting switch must be turned off immediately. Then the core along with the pinion returns to the original place under the actuation of spring. The continuous working time for the starting motor should not exceed 15 seconds. The interval between two starting operations is 2~3 minutes. It is necessary to check and eliminate the faults in case of starting failure for three attempts. The electrifying time of the glow plug each time during operation is not permitted to be over 30 seconds.

## SECTION 6. FAULTS AND REMEDIES FOR DIESEL ENGINE

### I. Hard or refuse to Start (see Table 4)

**Table 4**

Causes	Remedies
1. Fuel filters and fuel pipelines blocked.	1. Clean.
2. Air trapped in fuel system.	2. Exhaust air and tighten all fuel pipeline connector.
3. Advanced fuel injection angle incorrect.	3. Readjust it according to specifications.
4. Fuel spray abnormal.	4. Readjust fuel injection pressure according to specifications and clean or replace injector needle valve sets.
5. Compression pressure low.	5. Check or replace piston rings, and cylinder liners. Grind valves. Cylinder head nuts should be tightened in case of leakage on cylinder head gaskets.
6. Valve lash incorrect	6. Adjust it according to specifications and align gear marks.
7. Battery charge insufficient.	7. Charge it.
8. Wire connections loosened.	8. Check and tighten wire connections. Clean up contact points.
9. Ambient temperature too low, and oil too viscous	9. Preheat cooling water and lube oil.

### II. Power Insufficient (see Table 5)

**Table 5**

Causes	Remedies
1. Compression pressure inside cylinders too low.	1. Refer to item 5 in paragraph I and replace components exceeding wear limit.
2. Advanced fuel injection angle incorrect.	2. Adjust it according to specifications.
3. Valve lash incorrect.	3. Adjust it according to specifications.
4. Fuel supply for each cylinder unbalanced.	4. Adjust fuel injection pumps to proper supply.
5. Air filter clogged.	5. Clean.
6. Fuel injection pumps, fuel injector sets worn off or fuel injection pressure incorrect.	6. Replace them with new sets, adjust fuel injection pressure and check fuel spray.
7. Rotation speed incorrect.	7. Adjust it with speed governing handle in order to reach specified speed.

### III.Smoking Exhaust (see Table 6)

**Table 6**

<b>Causes</b>	<b>Remedies</b>
1.Engines overloaded.	1.Reduce the load properly and in case of unsuited matching, adjustment should be made.
2.Fuel injectors not well atomized	2.Check the injection pressure and fuel spray. Replace then in case of damage.
3.Fuel unqualified	3.Use qualified fuel.
4.Combustion incomplete	4.Mainly caused by unqualified fuel injectors, incorrect advanced fuel injection angle,leakage at cylinder head gaskets and low compression pressure.Remedy in accordance with specific problems.

### IV.Knocking Noise in Engine (see Table 7)

**Table 7**

<b>Causes</b>	<b>Remedies</b>
1.Advanced fuel injection angle incorrect.	1.Readjust it according to specification.
2.Air trapped in fuel systems.	2.Exhaust air.
3.Fuel supply for each cylinder unbalanced.	3.Readjust fuel supply.
4.Fuel unqualified.	4.Use qualified supply.
5.Wear of certain components exceeds limits	5.Replace them.

### V.Lube Oil Insufficient or No Pressure (see Table 8)

**Table 8**

<b>Causes</b>	<b>Remedies</b>
1.Oil level in oil sumps too low.	1.Add oil up to mark line on dip sticks.
2.Serious leakage from oil pipelines.	2.Eliminate leakage.
3.Oil strainers,oil filters and pipelines clogged.	3.Clean and replace elements if necessary.
4.Oil gauges damaged or gauge lines clogged.	4.Check and replace elements if necessary
5.Oil too thin.	5.Use qualified oil.
6.Oil pump gears seriously worn off ,with excessive clearance.	6.Adjust the clearance or replace them.
7.Pressure relief valves of oil filter cease to function.	7.Check and repair or readjust them.
8.Main bearings, connecting-rod bearings and camshaft bushings seriously worn off with excessive clearance.	8.Check and repair or replace them.

**VI.Overheating of Engine** (see Table 9)

**Table 9**

<b>Causes</b>	<b>Remedies</b>
<p>1.Temperature of cooling water too high;</p> <p>(1)Insufficient cooling water or vapor lock in water pipes.</p> <p>(2)Bad working state of water pumps.</p> <p>(3)Water scale in cooling systems too thick.</p> <p>2.Oil temperature too high:</p> <p>(1)Insufficient or excessive oil.</p> <p>(2)Oil pressure too low with insufficient flow.</p> <p>3.Engines overloaded</p>	<p>(1)Fill the tank to make cooling water level higher than the center line of water pump.</p> <p>(2)Check water pump clearance and tightness of belts. Eliminate leakage.</p> <p>(3)Remove it.</p> <p>(1)Check whether the oil level is between the dip stick scale lines.</p> <p>(2)Refer to paragraph V.</p> <p>3.Relieve load.</p>

**VII.Engine Running-away** (see Table 10)

**Table 10**

<b>Causes</b>	<b>Remedies</b>
<p>1.Malfunction of governors.</p> <p>2.Control rod fuel injection pump gets stuck.</p> <p>3.Injection pump delivery too much.</p> <p>4.Excessive oil burnt.</p>	<p>1.Stop engines immediately, check and repair.</p> <p>2.Stop engines immediately, check and repair.</p> <p>3.Stop the engine and readjust injection pump delivery.</p> <p>4.Stop engines immediately,check and repair.</p>

MANUFACTURING LICENSE: XK06 - 205 - 00141  
PRODUCT STANDARD: Q/321284 JCA06 - 2002  
LICENSE APPROVAL DATE: JULY 2, 2003

