

TP μ P-A SERIES

MICROPRINTER

USER'S MANUAL

(August 1992)

CONTENTS

Introduction.....	3
Chapter 1 Features and Specifications	
1.1 Models.....	3
1.2 Interface.....	4
1.3 Character Codes.....	4
1.4 Print Commands.....	4
1.5 Working Modes.....	4
1.6 "Off-Line" Printing.....	4
1.7 Specifications.....	4
Chapter 2 Installation	
2.1 Measurements.....	6
2.2 Method of Installation.....	7
2.3 Connecting Power Supply.....	8
2.4 Loading Ribbon Cassette.....	8
2.5 Loading Paper.....	9

Chapter 3 Operation

3.1 Checking Model.....	11
3.2 Parallel Interface Connection.....	11
3.3 Serial Interface Connection.....	12
3.4 Indicator and Switches Operation.....	16
3.5 Self-Test.....	17
3.6 Printer Initialization.....	17

Chapter 4 Printing Commands

4.1 Summary.....	18
4.2 Paper Feeding Commands.....	19
4.3 Formatting Commands.....	20
4.4 Character Setting Commands.....	25
4.5 User-Defined Character Commands.....	30
4.6 Graphics Commands.....	32
4.7 Initialization Command.....	36
4.8 Data Control Commands.....	36
4.9 Hexadecimal Dump Printing Command.....	37

Chapter 5 Operating Note..... 38

Appendix A Specifications.....	39
Appendix B DIP Switch.....	41
Appendix C Character Code Tables.....	42
Appendix D Self-Test Samples.....	43
Appendix E Printing Command Codes.....	46
Appendix F Parallel Interface and Operation.....	48
Appendix G Serial Interface and Operation.....	49
Appendix H Option List.....	50
Appendix I Printer Outline.....	51

Warning !

The power supply of TP μ P-A series printers is
only DC +5V.

Never use AC mains !

Introduction

TP μ P-A is a new series of panel-mounted impact dot-matrix microprinters. All members of this series are very easy to mount on the instrument panel. These instruments then can print ASCII characters, curves, or any other required print function.

TP μ P-A comes in six models with different print speeds, line widths, and interfaces. They print 16, 24 or 40 characters per line. Interfaces are standard parallel CENTRONICS compatible or serial RS-232C compatible. TP μ P-A provides 36 standard ESC print commands.

TP μ P-A series printers operate with single DC 5 volt power supply. They have a compact size: 111mm(W)x62mm(H)x128mm(D).

Chapter 1. Features and Specifications

1.1 Models

The models of TP μ P-A series are shown as follows:

TP μ P-A16S

16 character line width, 1 line per second printing speed and RS-232 serial interface.

TP μ P-A16P

16 character line width, 1 line per second printing speed and CENTRONICS parallel interface.

TP μ P-A24S

24 character line width, 0.7 line per second printing speed and RS-232 serial interface.

TP μ P-A24P

24 character line width, 0.7 line per second printing speed and CENTRONICS parallel interface.

TP μ P-A40S

40 character line width, 0.4 line per second printing speed and RS-232 serial interface.

TP μ P-A40P

40 character line width, 0.4 line per second printing speed and CENTRONICS parallel interface.

1.2. Interface

The Serial Interface, compatible with RS-232C standard, is linked with the master computer through a 9 pin D type connector and cable. The Parallel Interface, compatible with CENTRONICS, is linked with the master computer through a 26-pin connector and a ribbon cable. For details see "Interface" sections - Chapter 3 and Appendix F & G.

1.3. Character Codes

TP μ P-A provides a font with 448 characters in the internal ROM. The font includes English, Greek, German, French, Russian, Japanese and Chinese characters, math symbols, specific meaning symbols and tabulation symbols. Characters are 5 x 7 dot matrix and graphics 6 x 8. 32 special characters can also be defined with the print program.

TP μ P-A provides Bit Image mode. The Bit Image mode can be mixed with characters on the same line.

1.4. Print Commands

TP μ P-A provides 36 print commands. Most of these are compatible with the popular standard. TP μ P-A can be substituted for 9 pin printers or even 24 pin printers usually without modification. Some new commands are added for special features. The command for printing curves, convenient for plotting graphs, is an example.

1.5. Working Modes

TP μ P-A has six working modes - Dump, Text, Bit Image, Self-Test, On/Off Line and Paper Feed mode. The first three modes are selected by control commands and the last three by button switches. See Chapters 3 and 4.

1.6. "Off-Line" Printing

For some applications, particularly for industrial control, a faster printing process is needed. To provide this a buffer storage may be added. The master computer transfers data to the buffer very fast. Then the printer prints "Off-Line" and the computer can proceed to other jobs without delay. There are three sizes of printer buffer, 0.5K, 6.5K and 30.5K bytes. (6.5K and 30.5K are optional extras.)

1.7. Specifications

The general features of TP μ P-A series are listed as follows:

1. Interface - Parallel or Serial

The Parallel Interface is compatible with CENTRONICS standard. The data bus DB0 - DB7 is one direction. Synchronous signal STB is sent from the master computer. Information on the present condition of the printer is sent to the master computer by signal ACK, BUSY, and SFL.

Signal level is TTL standard.

The Serial Interface is compatible with RS-232C standard. The Baud Rate may be selected as 150, 300, 600, 1200, 2400, 4800, 9600 or 19200 bps. Transmission is asynchronous. Handshaking is by Flag Control or X-ON/X-OFF Protocol. The Parity Check can be selected as Even, Odd or None by setting an internal DIP switch. The signal level is EIA standard.

2. Indicator and Switches

A green LED lamp indicates the status of the printer : On Line or Off Line. There are two push button switches, SEL (SElect On/Off Line) and LF (Line Feed).

3. Power supply

Single DC 5 Volt only. The required current is 1.5 Amps MAX.

4. Ribbon

Life time is 10,000 lines. Two colours - black or blue.

5. Printing Paper

Plain white paper. Paper width 44.5 +/- 0.5 mm for TP μ P-A16, or 57.5 +/- 0.5mm for the other models. Thickness 0.07mm. The outer diameter of paper roll must be not more than 40mm.

Specifications of six models are shown as follows:

Parameters of 6 Models of TP μ P-A Series

Model	Char./Line (5x7)	Char. Size (WxH mm)	Dot Size (WxH mm)	Dots/Line	Speed (Lines/Sec)	Interface
TP μ P-A16P	16	1.8x2.5	0.35x0.35	96	1.0	CENTRONICS
TP μ P-A16S						RS-232C
TP μ P-A24P	24	1.7x2.4	0.33x0.37	144	0.7	CENTRONICS
TP μ P-A24S						RS-232C
TP μ P-A40P	40	1.1x2.4	0.20x0.33	240	0.4	CENTRONICS
TP μ P-A40S						RS-232C

Chapter 2. Installation

2.1 Measurements

The appearance of TP μ P-A series printer is shown in Figure 2-1. And measurements of the outline in Appendix I.

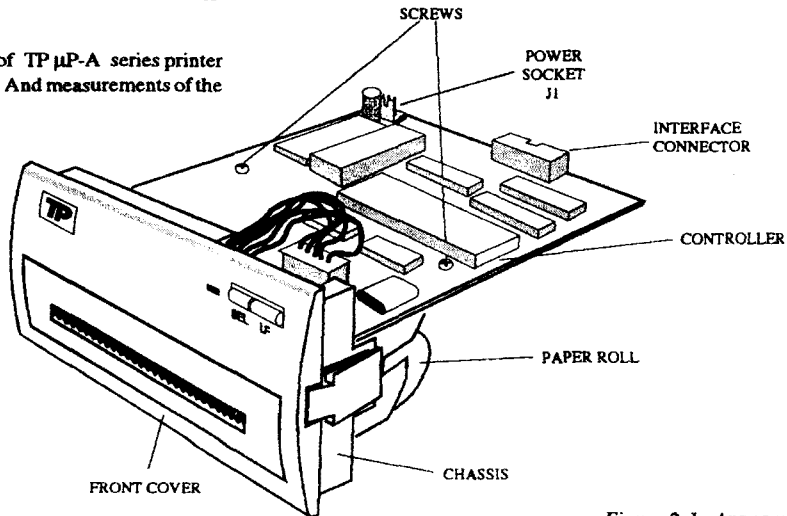

Figure 2-1. Appearance of TP μ P-A series printer

To install TP μ P-A onto an instrument panel an opening is required with measurements as shown in Figure 2-2.

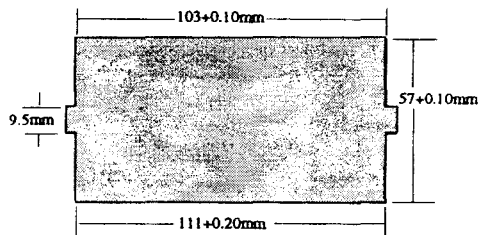

Figure 2-2 Measurement of Opening

2.2 Method of Installation

Spring clips will be found on both sides of the printer chassis. To install TP μ P-A press these spring clips and insert chassis into the opening as Figure 2-3. The spring clips should secure this firmly in place. A steel or aluminium plate of 0.8 - 1.2 mm is recommended as a base plate on the instrument panel.

The Chassis and Controller can be placed in instrument separately. Take off two screws on the Controller. The Controller is linked with Chassis by two cables as Fig. 2-4.

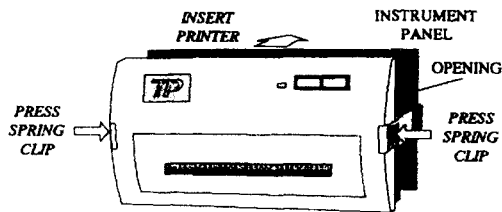

Figure 2-3 Install TP μ P-A on the Panel of Instrument

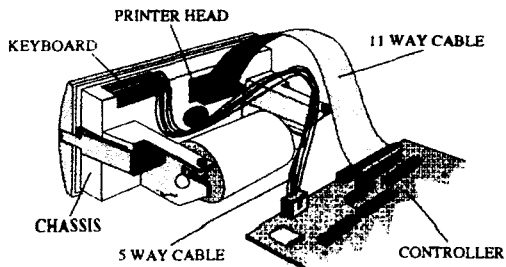

Figure 2-4 Two cables link TP μ P-A Chassis and Controller when they are placed separately

2.3 Connecting Power Supply

TP μ P-A printers require a single 5 Volt DC power supply. Capacity is not less than 1.5 Amps. Voltage Tolerance 4.5 - 5.5 V. Before switching on check polarity, voltage and capacity of the power supply. Exceeding the normal range of TP μ P-A or connecting wrongly, may make the printer work poorly or even cause permanent damage.

TP μ P-A is provided with a two-wire power cable - RED positive, WHITE negative. The plug fits socket J1 on the controller board. This plug is protected to prevent wrong polarity.

2.4 Loading Ribbon Cassette

Ribbon Cassette has been loaded inside the printer before packing. When the printing becomes faint, load a new Ribbon Cassette as follows:

1. Take off Front Cover. (Note arrow. Figure 2-5.)

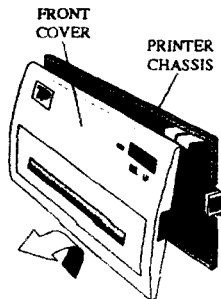

Fig. 2-5. Take off Front Cover

2. Remove old cassette (Figure 2-6)

Caution - First lift the left end of Ribbon Cassette, then right.

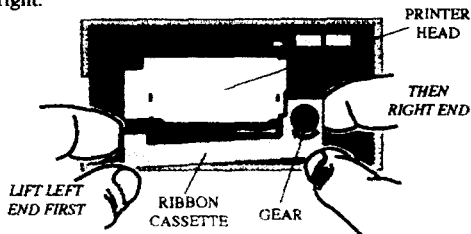

Fig. 2-6. Remove Ribbon Cassette

3. Replace a new Ribbon Cassette.

Remove Paper Roll. Put the right end of the Cassette onto the Axle on the Printer Head, then the left end. If it is difficult to push the right end down rotate the Gear slightly as indicated. (See arrow on Cassette Cover.) When the Cassette clips into place, check that the ribbon is straight. If not, rotate Gear.

4. Replace Front Cover.

2.5 Loading Paper

With the TP μ P-A as shipped a roll of paper has been loaded but has not been fed to the Printer Head. This is to prevent damage. Before use prepare as follows:

1. Switch off.
2. Take off Front Cover.
3. Remove TP μ P-A from instrument panel (Figure 2-7).

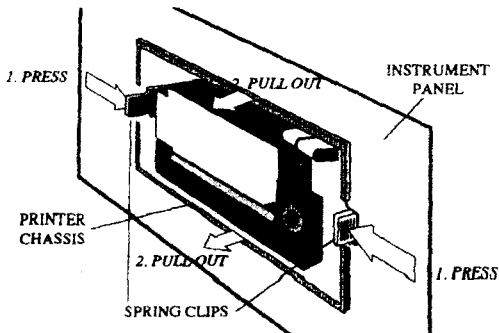

Fig. 2-7. Remove Printer

4. If a roll has not been installed, remove the Axle Rod (Figure 2-8); slide on Paper Roll; and replace loaded Axle Rod in slots (Figure 2-9).

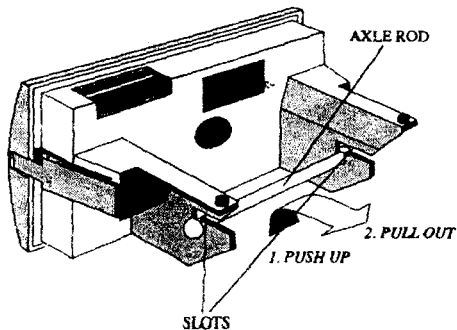

Fig. 2-8. Remove Axle Rod

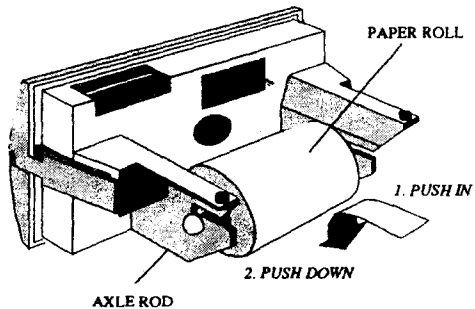

Fig. 2-9. Replace Axle Rod and Paper Roll

5. Cut paper as Figure 2-10.

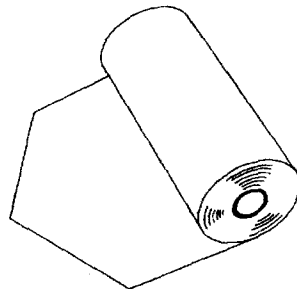

Fig. 2-10. Cut Paper

6. Feed paper to Printer Head.

Turn on power. Press SEL Key until LED Indicator turns off. Then press LF. Motor starts. Feed paper to Printer Head. When paper begins to come out of the Exit Slot press LF or SEL Key to stop motor. Switch off power.

7. Replace Printer Chassis in instrument panel and clip on Front Cover.

Chapter 3. Operation

3.1 Checking Model

The TP μ P-A is shown in Fig. 2-1. Check model No. on the label. Read special instructions on this model in the manual

3.2 Parallel Interface Connection

TP μ P-AXXP microprinter has a parallel interface. The interface is compatible with CENTRONICS standard. The interface connector is a 26-way socket with 0.1" pin pitch. (Fig. 3-1.) This socket connects with a plug provided by user. The recommended plug is model 5320-26 of MOLEX.

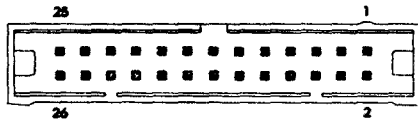

Fig. 3-1. Pin order of the connector for Parallel Interface

The descriptions of signals are listed in Figure 3-2.

Pin No.	Signal	In/Out	Description
1	$\overline{\text{STB}}$	IN	Strobe pulse to read data in
3	DATA1	IN	These signals represent information of the 1st to 8th bits of parallel data respectively. Each signal is at "HIGH" level when data is logical "1" and "LOW" when logical "0"
5	DATA2	IN	
7	DATA3	IN	
9	DATA4	IN	
11	DATA5	IN	
13	DATA6	IN	
15	DATA7	IN	
17	DATA8	IN	
19	$\overline{\text{ACK}}$	OUT	Acknowledge pulse, "LOW" indicates that data has been received and that the printer is ready to accept next data.
21	BUSY	OUT	Signal set "HIGH" to indicate the printer cannot accept data.
23	PE	-----	Pull-down to ground.
25	SEL	OUT	Pull-up to +5V through 3.3k resistor, to indicate the printer in ON-LINE.
4	$\overline{\text{ERROR}}$	OUT	Pull-up to +5V through 3.3k resistor.
2, 6, 8, 26	NC	-----	No connection
10-24	GND	-----	Ground, Logical "0" level.

Fig. 3.2 Descriptions of Parallel Interface signals

Signal level is TTL standard.

The signal timing chart of parallel interface is shown in Figure 3-3.

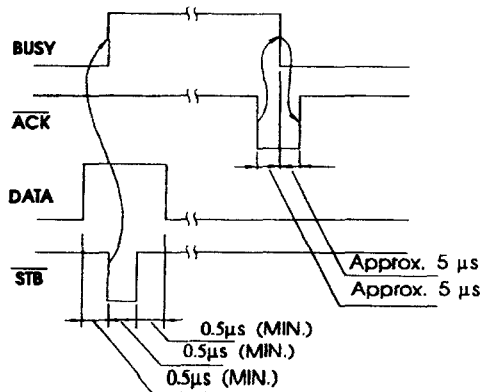

Fig. 3-3. Signal timing chart of parallel interface

3.3 Serial Interface Connection

TP μ P-AXXS microprinter is a serial interface printer. The interface is compatible with RS-232C standard. The interface connector on the Controller of TP μ P-AXXS is a 9-pin D-type connector (female, Fig. 3-4). The connector provided by user is 9-pin D-type connector (male).

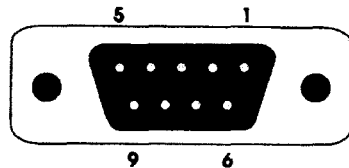

Fig. 3-4. Hole order of the connector of serial interface

The descriptions of signals are listed in Figure 3-5.

Pin No.	Signal	Source	Description
1	DCD	Printer	Same as CTS
2	RxD	Printer	Printer transmits data when uses the hand-shaking of X-ON/X-OFF
3	TxD	Host	Printer receives data from host computer
5	GND		Signal ground
6	DSR	Printer	Signal set "SPACE" to indicate the printer is ON-LINE
8	CTS	Printer	Signal set "MARK" state to indicate the printer is BUSY and can not accept data, and "SPACE" state to indicate the printer is ready and can accept data

Fig. 3-5. Descriptions of serial interface signals

Signal level is compatible with EIA standard.

The Baud Rate of serial interface can be selected as 150, 300, 600, 1200, 2400, 4800, 9600 or 19200 bps. It can be set with internal DIP switches as required. To set the Baud Rate, take off the removable Front Cover and pull the printer out. You can see the DIP switch in the upper right corner of the PCB. Baud Rate can be selected as in Figure 3-6. Switch near the white mark is K1. The setting is K1 ON, K2 OFF, K3 OFF ex-factory, i.e. 9600 bps.

DIP SWITCH	BPS
ON <input checked="" type="checkbox"/> <input checked="" type="checkbox"/> <input checked="" type="checkbox"/> <input type="checkbox"/> <input type="checkbox"/> <input type="checkbox"/> <input type="checkbox"/> <input type="checkbox"/> <input type="checkbox"/> <input type="checkbox"/> <input type="checkbox"/> <input type="checkbox"/> 1 2 3 4 5 6	150
ON <input type="checkbox"/> <input checked="" type="checkbox"/> <input checked="" type="checkbox"/> <input type="checkbox"/> <input type="checkbox"/> <input type="checkbox"/> <input type="checkbox"/> <input type="checkbox"/> <input type="checkbox"/> <input type="checkbox"/> <input type="checkbox"/> <input type="checkbox"/> 1 2 3 4 5 6	300
ON <input checked="" type="checkbox"/> <input checked="" type="checkbox"/> <input type="checkbox"/> <input type="checkbox"/> <input type="checkbox"/> <input type="checkbox"/> <input type="checkbox"/> <input checked="" type="checkbox"/> <input type="checkbox"/> <input type="checkbox"/> <input type="checkbox"/> <input type="checkbox"/> 1 2 3 4 5 6	600
ON <input type="checkbox"/> <input type="checkbox"/> <input checked="" type="checkbox"/> <input type="checkbox"/> <input type="checkbox"/> <input type="checkbox"/> <input checked="" type="checkbox"/> <input checked="" type="checkbox"/> <input type="checkbox"/> <input type="checkbox"/> <input type="checkbox"/> <input type="checkbox"/> 1 2 3 4 5 6	1200
ON <input checked="" type="checkbox"/> <input checked="" type="checkbox"/> <input type="checkbox"/> <input type="checkbox"/> <input type="checkbox"/> <input type="checkbox"/> <input type="checkbox"/> <input checked="" type="checkbox"/> <input type="checkbox"/> <input type="checkbox"/> <input type="checkbox"/> <input type="checkbox"/> 1 2 3 4 5 6	2400
ON <input type="checkbox"/> <input checked="" type="checkbox"/> <input type="checkbox"/> <input type="checkbox"/> <input type="checkbox"/> <input type="checkbox"/> <input checked="" type="checkbox"/> <input type="checkbox"/> <input checked="" type="checkbox"/> <input type="checkbox"/> <input type="checkbox"/> <input type="checkbox"/> 1 2 3 4 5 6	4800
ON <input checked="" type="checkbox"/> <input type="checkbox"/> <input type="checkbox"/> <input type="checkbox"/> <input type="checkbox"/> <input type="checkbox"/> <input type="checkbox"/> <input checked="" type="checkbox"/> <input checked="" type="checkbox"/> <input type="checkbox"/> <input type="checkbox"/> <input type="checkbox"/> 1 2 3 4 5 6	9600
ON <input type="checkbox"/> <input type="checkbox"/> <input type="checkbox"/> <input type="checkbox"/> <input type="checkbox"/> <input type="checkbox"/> <input checked="" type="checkbox"/> <input checked="" type="checkbox"/> <input checked="" type="checkbox"/> <input type="checkbox"/> <input type="checkbox"/> <input type="checkbox"/> 1 2 3 4 5 6	19200

Fig. 3-6. Baud Rate selection

The format of serial data is asynchronous as shown in Figure 3-7.

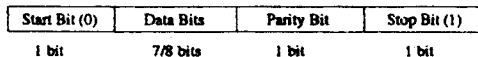

Fig. 3-7. Asynchronous transmitting format

START bit and STOP bit are one bit signals. These signals come at the beginning and the end of a computer message. The computer message, the DATA, has seven or eight bits, plus a Parity Check bit. The Data bits and Parity Check can be set with K5 and K6 switches as in Figure 3-8. These are set at NonParity ex-factory, K5 ON, K6 ON.

DIP SWITCH	PARITY
ON <input type="checkbox"/> <input type="checkbox"/> <input type="checkbox"/> <input type="checkbox"/> <input checked="" type="checkbox"/> <input checked="" type="checkbox"/> <input type="checkbox"/> <input type="checkbox"/> <input type="checkbox"/> <input type="checkbox"/> <input type="checkbox"/> <input type="checkbox"/> 1 2 3 4 5 6	8-NON
ON <input type="checkbox"/> <input type="checkbox"/> <input type="checkbox"/> <input type="checkbox"/> <input checked="" type="checkbox"/> <input type="checkbox"/> <input type="checkbox"/> <input type="checkbox"/> <input type="checkbox"/> <input type="checkbox"/> <input type="checkbox"/> <input checked="" type="checkbox"/> 1 2 3 4 5 6	8-ODD
ON <input type="checkbox"/> <input type="checkbox"/> <input type="checkbox"/> <input type="checkbox"/> <input type="checkbox"/> <input checked="" type="checkbox"/> <input type="checkbox"/> <input type="checkbox"/> <input type="checkbox"/> <input checked="" type="checkbox"/> <input type="checkbox"/> <input type="checkbox"/> 1 2 3 4 5 6	8-EVEN
ON <input type="checkbox"/> <input type="checkbox"/> <input type="checkbox"/> <input type="checkbox"/> <input checked="" type="checkbox"/> <input checked="" type="checkbox"/> <input type="checkbox"/> <input type="checkbox"/> <input type="checkbox"/> <input checked="" type="checkbox"/> <input type="checkbox"/> <input type="checkbox"/> 1 2 3 4 5 6	7-EVEN

Fig. 3-8. Parity selection

The signal polarity of serial RS-232C is:

Mark = Logic "1" (EIA low level, -3V to -27V)

Space = Logic "0" (EIA high level, +3V to +27V)

There are two kinds of Handshaking to be selected. First is the flag control. The other is the X-ON/X-OFF protocol. It is selected with K4 as in Figure 3-9. The K4 is set to OFF ex-factory.

DIP SWITCH	HANDSHAKING
ON <input type="checkbox"/> <input type="checkbox"/> <input type="checkbox"/> <input checked="" type="checkbox"/> <input type="checkbox"/> <input type="checkbox"/> <input type="checkbox"/> <input type="checkbox"/> <input type="checkbox"/> <input type="checkbox"/> 1 2 3 4 5 6	FLAG
ON <input type="checkbox"/> <input type="checkbox"/> <input type="checkbox"/> <input type="checkbox"/> <input type="checkbox"/> <input type="checkbox"/> <input type="checkbox"/> <input checked="" type="checkbox"/> <input type="checkbox"/> <input type="checkbox"/> 1 2 3 4 5 6	XON/XOFF

Fig. 3-9. Handshaking selection

Two kinds of Handshaking are listed in Figure 3-10.

Handshaking	Data Direction	RS-232 Interface's Signal
Flag Control	Can accept data	Line 1 & 8 are SPACE state
	Can't accept data	Line 1 & 8 are MARK state
X-ON/X-OFF Control	Can accept data	Send X-ON code (11H) on line 2
	Can't accept data	Send X-OFF code (13H) on line 2

Fig. 3-10. Two kinds of Handshaking

The operation procedure of serial interface is shown as follows:

- (1) Select Baud Rate with switches K1 - K3.
- (2) Select Data bits and Parity with switches K5 and K6.
- (3) Select Handshaking with switch K4.
- (4) When only 32 bytes free space is left in the printer buffer, signal DCD (line 1) and CTS (line 8) are both set to "busy", i.e. Mark status, by printer. Otherwise set to "ready", i.e. Space status.
- (5) Under X-ON/X-OFF control Handshaking, the printer sends X-OFF code (13 in Hex.) when it is busy, sends X-ON code (11 in Hex.) when ready. Under Flag control Handshaking, host computer sends data to printer when both DCD and CTS are ready.

3.4 Indicator and Switches Operation

There are one green LED indicator and two button switches on the panel of the printer. A button switch is labelled "SEL" for selecting On/Off Line. Another is labelled "LF" for paper Line Feeding.

On/Off-Line status is indicated by the green LED. When the indicator is On the printer is On-Line. The SEL button changes this status.

Three working mode - Self-Test, On/Off Line and Paper Feed are selected by SEL and LF buttons.

1. Self-Test Mode

There are two ways to enter the Self-Test mode.

(1) When Power On Press SEL button for a few seconds, then release. The indicator then turns off and the printer prints out Self-Test sample.

(2) With Power On and printer Off-Line, press and hold LF and then press SEL. Release both buttons together. The printer will enter Self Test mode

There are also two ways to exit the Self-Test mode.

(1) The printer will exit Self-Test mode automatically after printing the Self-Test sample.

(2) When the Self-Test sample is being printed, it can be terminated by pressing the SEL button.

2. On/Off Line Mode

After switching on or exiting from the Self-Test mode, the printer enters On-Line mode. The green indicator lights up. Press the SEL button, green indicator goes off. Printer enters Off-Line mode and can not receive data. Press SEL again. Printer re-enters the On-Line mode.

SEL has another function - to interrupt the printout. If SEL is pressed and then released during a printout, the printer will stop after completing the current line. At this point you can feed more paper. To complete the printout, press and release SEL button. The printer will run again at the point printout was interrupted.

3. Paper Feed Mode

When print procedure is interrupted, green LED off, the printer enters Off-Line mode. If paper has to be replaced, press LF button, then release. Printer will feed paper without printing. Re-press LF, then release, printer will stop paper feed. Press SEL, printer re-enters On-Line mode. Printer can also re-enter On-Line mode in the Paper Feed procedure by pressing the SEL button.

3.5 Self-Test

Self-Test checks condition of printer. If the printer prints out the Self-Test sample correctly It is working normally. Faults, if they exist, can not lie in the printer and must in the interface or master computer. If Self-Test does not run or prints out a faulty sample, check Power Supply. If power is OK, the printer itself requires attention.

Self-Test prints out all characters in the fonts. Then prints the messages about interface type and printer head model. (See Appendix D.)

After Self-Test the printer enters On-Line mode. It can then receive data from the master computer.

3.6 Printer Initialization

Initialization includes default value settings. Default values are: 3 dot Line Spacing, 40 lines Form Length, 0 values of Vertical Tab and Horizontal Tab, 0 values of Right Margin and Left Margin, normal alphanumeric and graphic character size (i.e. Enlarge Factor is 1). Initialization clears all user defined characters and data in printing buffer, and selects character set 1, then sets printer to On-Line mode, i.e. ready to receive commands and data.

There are three ways to realize Initialization.

First - run Initialization software on master computer. Master computer sends Initialization command (ESC @) to printer.

Second - through Self-Test procedure.

Third - power on Initialization.

Chapter 4. Printing Commands

4.1 Summary

TP μ P-A provides up to 36 printing commands. These command special functions:

- (1) Define formatting.
- (2) Enlarge or condense characters.
- (3) Print image graphics.
- (4) Select font.
- (5) Define special characters.
- (6) Other.

Some of these commands consist of a one byte control code. Some are ESC code sequences. The latter sequences start with "ESC", followed by other alphanumeric characters.

Printer's control codes (especially ESC control codes) are not standardized. Every printer manufacturer has his own code system. Control codes for the TP μ P-A series were designed with reference to the popular printer. Hence, they are compatible with most printers.

Printing commands are described under five headings

set out below:

Code Sequence
Function
Format
Explanation
Example

Code Sequence	Function
Format: ASCII :	the sequence in standard ASCII characters.
Decimal :	the sequence in decimal numbers.
Hexadecimal:	the sequence in hexadecimal numbers.

Explanation:

A description of the effect of issuing the command, i.e. what the command does.

Example:

Some program examples are listed to illustrate the commands. These printing commands are introduced below according to the type of function they perform.

4.2 Paper Feeding Commands

LF	Line Feed
----	-----------

Format: ASCII : LF

Decimal : 10

Hexadecimal: 0A

Explanation:

Print the data in the buffer of the printer and feed paper one line. If no data in the buffer feed paper one line only.

ESC J	Perform Dot-Line Feed
-------	-----------------------

Format: ASCII : ESC J n

Decimal : 27 74 n

Hexadecimal: 1B 4A n

Explanation:

Immediate Line Feed for n dot lines without Carriage Return. The value of n can be any number in the range 1 - 255.

Enlarge character commands ESC V or ESC W (refer to Section 4.4) enlarge line spacing and consequently change the value of any following ESC J command.

ESC I	Set line spacing
-------	------------------

Format: ASCII : ESC I n

Decimal : 27 49 n

Hexadecimal: 1B 31 n

Explanation:

The line spacing is set to n dot-lines for future Line Feed commands.

The value of n can be any number in the range 1 - 255. Normal settings are n=0 for ESC K Bit Image print mode and n=3 for text print mode.

Example:

The BASIC program for this command is shown below:

```
10 FOR I=1 TO 11 STEP 2
```

```
20 LPRINT CHR$(27);"I";CHR$(I); 'ESC I  
'set line spacing
```

```
30 LPRINT "LINE SPACING";CHR$(10);
      'print string and Line Feed
40 NEXT I
```

A printout of the above the program on TP μ P-A:

```
LINE SPACING
LINE SPACING
LINE SPACING
LINE SPACING
LINE SPACING
LINE SPACING
```

FF Form feed

Format: ASCII : FF
Decimal : 12
Hexadecimal: 0C

Explanation:

Feed paper to the beginning position of next page.

4.3 Formatting Commands

ESC C Set page length in lines

Format: ASCII : ESC C n
Decimal : 27 67 n
Hexadecimal: 1B 43 n

Explanation:

The page length is set to n lines. The value of n should be within the range 0 to 255. If n=0, the page length will be 256 line. Default value n=40.

ESC N Set bottom margin

Format: ASCII : ESC N n
Decimal : 27 78 n
Hexadecimal: 1B 4E n

Explanation:

The bottom margin is set to n lines. The value of n should be within the range 0 to 255. Default value n=0. In TP μ P-A, the bottom margin is the spacing between the last

line of a page and the first line of the next page.

Example:

To set the bottom margin to 3 lines, send the following sequence:

ASCII : ESC N ETX

Decimal : 27 78 3

Hexadecimal : 1B 4E 03

BASIC program:

```
LPRINT CHR$(27);"N";CHR$(3);
```

ESC O

Cancel bottom margin

Format: ASCII : ESC O

Decimal : 27 79

Hexadecimal : 1B 4F

Explanation:

The bottom margin is set to zero. This means the printer will print line by line without page breaks.

ESC B

Set vertical tabs

Format: ASCII : ESC B n1 n2 n3 ... NUL

Decimal : 27 66 n1 n2 n3 ... 0

Hexadecimal : 1B 42 n1 n2 n3 ... 00

Explanation:

The tab positions are entered as n1, n2, and so on. These n1, n2, ... are within the page length set by ESC C command.

The NUL character is added to indicate the end of the command.

All vertical tab settings can be cleared by using this command in the format ESC B NUL.

VT command executes vertical tab, and feeds paper to next tab position.

Example:

To set three vertical tabs at lines 2, 5 and 8 on a page, you would send the following commands:

ASCII : ESC B STX ENQ BS NUL

Decimal : 27 66 2 5 8 0

Hexadecimal : 1B 42 02 05 08 00

BASIC program:

```

10 LPRINT
   CHR$(27);"B";CHR$(2)CHR$(4)CHR$(6)CHR$(0);
                                     'ESC B commands
20 LPRINT CHR$(11);                 'VT command
30 LPRINT "VTAB1";                  'print string
40 LPRINT CHR$(11);                 'VT command
50 LPRINT "VTAB2";                  'print string
60 LPRINT CHR$(11);                 'VT command
70 LPRINT "VTAB3";                  'print string

```

Printout:

UTAB3

UTAB2

UTAB1

VT Vertical tab

Format: ASCII : VT

Decimal : 11

Hexadecimal : 0B

Explanation:

Feed paper to next vertical tab set by ESC B command.

Note: If no vertical tab setting or if current position equals or exceeds the last vertical tab, command VT feeds paper one line (same as LF command). If the position setting with ESC B exceeds the current position, no line feed is performed for such position.

ESC D

Set horizontal tabs

Format: ASCII : ESC D n1 n2 ... NUL

Decimal : 27 68 n1 n2 ... 0

Hexadecimal: 1B 44 n1 n2 ... 00

Explanation:

The tab positions are entered as n1, n2 and so on. These n1, n2, ... are within the line width of the printer. (See 1.7.)

The NUL character is added to indicate the end of the command.

All horizontal tab settings can be cleared by using this command in the format ESC D NUL.

HT command executes horizontal tab.

Example:

To set three horizontal tabs at character positions 2, 9 and 14, you would send the following commands:

ASCII :	ESC D	STX	HT	SO	NUL	
Decimal :	27	68	2	9	14	0
Hexadecimal :	1B	44	02	09	0E	00

The BASIC program for this example is set out below:

```
10 LPRINT "1234567890123456"          'scalar
```

```
20 LPRINT
```

```
CHR$(27);"D";CHR$(2)CHR$(9)CHR$(14)CHR$(0);
```

'ESC D

```
30 LPRINT CHR$(9);                    'HT command
```

```
40 LPRINT "HT1";                       'print string
```

```
50 LPRINT CHR$(9);                    'HT command
```

```
60 LPRINT "HT2";                       'print string
```

```
70 LPRINT CHR$(9);                    'HT command
```

```
80 LPRINT "HT3"                        'print string
```

The printout from this program on TP μ P-A is:

```
HT1    HT2    HT3
1234567890123456
```

HT

Horizontal tab

Format: ASCII : HT

Decimal : 9

Hexadecimal : 09

Explanation:

The printing position is advanced to the next horizontal tab set by ESC D command.

If no Horizontal Tab setting or if the current print position equals or exceeds the last Horizontal Tab, HT command does not execute.

ESC f

Print blank characters or lines

Format: ASCII : ESC f m n

Decimal : 27 102 m n

Hexadecimal : 1B 66 m n

Explanation:

If m=0, command ESC f NUL n will print n blank

characters. The value n should be within the line width of the printer (See 1.7).

If m=1, command ESC f SOH n will print n blank lines. The value n should be within the range 0 to 255.

Example:

To print 6 space characters in the line, send the following command:

ASCII :	ESC	f	NUL	ACK
Decimal :	27	102	0	6
Hexadecimal :	1B	66	00	06

To print 6 blank lines:

ASCII :	ESC	f	SOH	ACK
Decimal :	27	102	1	6
Hexadecimal :	1B	66	01	06

ESC Q Set right margin

Format: ASCII : ESC Q n
Decimal : 27 81 n
Hexadecimal : 1B 51 n

Explanation:

The value n should be within the line width of the printer

(See Section 1.7).

Default value n=0. No right margin.

The command sets an absolute position and is not affected by character enlarge command ESC U or ESC W.

When the right margin is reached, a Carriage Return and Line Feed is added.

Example:

To set the right margin to 6 columns, send:

ASCII :	ESC	Q	ACK
Decimal :	27	81	6
Hexadecimal :	1B	51	06

The BASIC program for this example is set out below:

```
10 LPRINT "1234567890123456"          'scale
20 LPRINT CHR$(27);"Q";CHR$(6);      'ESC Q
30 LPRINT "123456789012345678901234567890"
Printout on TP μP-A:
```

```
1234567890
1234567890
1234567890
1234567890123456
```

ESC I	Set left margin
--------------	------------------------

Format: ASCII : ESC I n
Decimal : 27 108 n
Hexadecimal : 1B 6C n

Explanation:

The value n should be within the line width of the printer (See Section 1.7). Default value n=0. This means no left margin.

The command sets an absolute position and is not affected by character enlarge command ESC U or ESC W.

Example:

To set the left margin to 6, you would send:

ASCII : ESC I ACK
Decimal : 27 108 6
Hexadecimal : 1B 6C 06

BASIC program:

```
10 LPRINT "1234567890123456" 'scale
20 LPRINT CHR$(27);"I";CHR$(6); 'ESC I
30 LPRINT "123456789012345678901234567890"
```

Printout on TP μ P-A:

```
1234567890
1234567890
1234567890
1234567890123456
```

4.4 Character Setting Commands

ESC U	Enlarge width
--------------	----------------------

Format: ASCII : ESC U n
Decimal : 27 85 n
Hexadecimal : 1B 55 n

Explanation:

Characters or graphics following this command are printed at n times normal width. The value n should be in the range 1 to 4. Default value n=1, i.e. normal width.

Example:

BASIC program:
10 FOR I=1 TO 3 'from 1 to 3 times

```

20 LPRINT CHR$(27);"U";CHR$(I);
                                'ESC U command
30 LPRINT "TP";
                                'print string
40 NEXT I
50 LPRINT CHR$(13);
                                'CR command
Printout:

```

TPTTP

Note: ESC U will not function unless preceded by ESC W SOH (n=1, see ESC W in this section), i.e. Set height and width to normal size before enlarging width ESC U.

ESC V Enlarge height

Format: ASCII : ESC V n
 Decimal : 27 86 n
 Hexadecimal : 1B 56 n

Explanation:

Characters or graphics following this command are printed at n times normal height. The value n should be within the range 1 to 4. Default value n=1, i.e. normal height.

This command can only be set at the beginning of a line.

Example:

```

BASIC program:
10 FOR I=1 TO 3
                                'from 1 to 3 times
20 LPRINT CHR$(27);"V";CHR$(I);
                                'ESC V command
30 LPRINT "TP"
                                'print string
40 NEXT I

```

Printout on TP μ P-A:

TP

TP
TP

Note: ESC V will not function unless preceded by ESC W SOH (n=1, see ESC W in this section), i.e. Set height and width to normal size before enlarging height ESC V.

ESC +	Turn overscore on/off
-------	-----------------------

Format: ASCII : ESC + n
Decimal : 27 43 n
Hexadecimal : 1B 2B n

Explanation:

Overscoring is turned on if n=1 and turned off if n=0.
All characters are overscored including spaces.

Example :

```
BASIC program :  
10 LPRINT "TP"  
20 LPRINT CHR$(27);"+";CHR$(1)           'turn on  
                                           overscore  
  
30 LPRINT "-PRINTER-";  
40 LPRINT CHR$(27);"+";CHR$(0);         'turn off  
                                           overscore  
  
50 LPRINT "TP"
```

Printout :

TP-PRINTER-TP

ESC 6	Select Font 1
-------	---------------

Format: ASCII : ESC 6
decimal : 27 54
Hexadecimal: 1B 36

Explanation:

Characters following this command are printed using
the Font 1 (See Appendix C).

There two fonts available in the TP μ P-A printer. Font
1 is selected at power on or on ESC @ command.

ESC 7	Select Font 2
-------	---------------

Format: ASCII : ESC 7
decimal : 27 55
Hexadecimal: 1B 37

Explanation:

Characters following this command are printed using
the Font 2 (See Appendix C).

Also see ESC 6.

SO Select double-width printing for one line

Format: ASCII : SO
 decimal : 14
 Hexadecimal: 0E

Explanation:

Characters following this command on the same line in the print buffer are printed at twice their normal width. The command is cancelled by a Carriage Return or using DC4 (see next command).

Normal and enlarged characters can be mixed on the same line, using SO-on ... DC4-off.

DC4 Cancel double-width

Format: ASCII : DC4
 Decimal : 20
 Hexadecimal: 14

Explanation:

Double-width printing is cancelled if it has been set

using SO. This command does not cancel enlarge width printing selected using ESC U or ESC W.

ESC i Turn reverse printing on/off

Format: ASCII : ESC i n
 Decimal : 27 105 n
 Hexadecimal: 1B 69 n

Explanation:

Reverse printing is turned on if n=1 and turned off if n=0. Reverse printing is white on black, as in a photographic negative.

Normal printing is black characters on a white background and is selected at power on or on ESC @ command.

Example:

```
BASIC program:
10 LPRINT CHR$(27);"i";CHR$(1);
                                     'turn on reverse printing
20 LPRINT " ABCDEFGHIJKLMNO"
```

Printout:



ESC c	Turn inverse printing on/off
--------------	------------------------------

Format: ASCII :	ESC c	n
Decimal :	27 99	n
Hexadecimal :	1B 63	n

Explanation:

Inverse printing (**NAOD ECHS UP**) is turned On if n=1, Off if n=0. Inverse printing is usual in TP μ P-A. ESC c supports also the inverse printing of Graphics, see ESC K command.

n=1 is selected at power on for TP μ P-A. ESC c is not changed on ESC @.

4.5 User-Defined Character Commands

ESC &	Define user-defined characters
------------------	--------------------------------

Format: ASCII :	ESC &	m	n1	n2 ...	n6
Decimal :	27 38	m	n1	n2 ...	n6
Hexadecimal:	1B 26	m	n1	n2 ...	n6

Explanation:

This command allows a character to be defined. The value m is the code of this user-defined character, and ranges from 32 to 255.

The values n_1, n_2, \dots, n_6 are codes for structure defined characters. Character size is 6 x 8 dot matrix. The relation of the structure and codes n_1, n_2, \dots, n_6 is shown below :

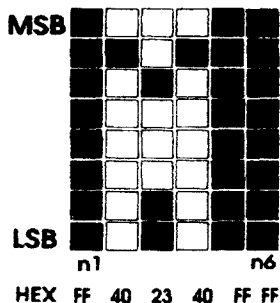

User-defined characters are stored in printer RAM until power off.

If many ESC & commands use same m value, only the last one is effective. The maximum number of user-defined characters is 32.

Also see ESC % and ESC : commands.

ESC % Replace with user-defined characters

Format: ASCII : ESC % $m_1 n_1 m_2 n_2 \dots m_k n_k$ NUL
 Decimal : 27 37 $m_1 n_1 m_2 n_2 \dots m_k n_k$ 0
 Hexadecimal : 1B 25 $m_1 n_1 m_2 n_2 \dots m_k n_k$ 00

Explanation:

This command is used to replace Font characters with user-defined characters.

m_1, m_2, \dots, m_k are codes of user-defined characters.

n_1, n_2, \dots, n_k are codes of the characters in the current font - the replaced characters.

The values m and n should be in the range 32 to 255.

The subscript k ranges from 1 to 32. The maximum number of replaced characters is 32.

The NUL character is added to indicate the end of the command.

Also see ESC & and ESC : commands.

ESC : Reinstates the Font characters

Format: ASCII : ESC :
Decimal : 27 58
Hexadecimal : 1B 3A

Explanation:

This command reinstates the original characters in the font replaced by user-defined characters using ESC % command. User-defined characters, however, are not deleted from the RAM in printer and may be brought back again with ESC %.

Example:

The BASIC program for showing ESC &, ESC % and ESC : commands is listed below:

```
10 LPRINT CHR$(27);"W";CHR$(2);
      'enlarge in W & H
20 LPRINT CHR$(27);"&";CHR$(65);
      'ESC & command
30 LPRINT
      CHR$(&HFF);CHR$(&H40);CHR$(&H23);
```

```
40 LPRINT
      CHR$(&H40);CHR$(&HFF);CHR$(&HFF);
50 LPRINT
      CHR$(27);"%";CHR$(65);CHR$(65);CHR$(0);
      'ESC %
60 LPRINT CHR$(65);
      'print defined char.
70 LPRINT CHR$(13);
80 LPRINT CHR$(27);";";
      'ESC : command
90 LPRINT CHR$(65)
      'reinstare char. in Font I
```

Printout on TP μ P-A :



4.6 Graphics Commands

ESC K Bit Image printing

Format: ASCII : ESC K n1 n2 ... data ...
Decimal : 27 75 n1 n2 ... data ...
Hexadecimal : 1B 4B n1 n2 ... data ...

BASIC program for inverse printing:

```
10 FOR E=1 TO 2
20 RESTORE 120
30 LPRINT CHR$(27);"W";CHR$(E);
                                     'enlarge in W & H
40 LPRINT CHR$(27);"1";CHR$(0);
                                     'line spacing = 0

50 FOR J=1 TO 2
60 LPRINT CHR$(27);"K";CHR$(16);CHR$(0);
                                     'ESC K command

70 FOR I=1 TO 16
80 READ D: LPRINT CHR$(D);
                                     'enter 16 bytes of data
90 NEXT I: LPRINT
                                     'enter CR
100 NEXT J: LPRINT: LPRINT
110 NEXT E: END
120 DATA &HC0, &H30, &H08, &H04
130 DATA &H04, &H72, &H92, &H12
140 DATA &H12, &H32, &H04, &H04
150 DATA &H08, &H30, &HC0, &H00
160 DATA &H07, &H18, &H20, &H40
170 DATA &H40, &H98, &H90, &H91
180 DATA &H91, &H9E, &H40, &H40
190 DATA &H20, &H18, &H07, &H00
```

Printout on TP μ P-A :



ESC ' **Print curving graph lines**

Format: ASCII : ESC ' m n1 n2 ... nk CR
Decimal : 27 39 m n1 n2 ... nk 13
Hexadecimal : 1B 27 m n1 n2 ... nk 0D

Explanation:

This command is designed to print curving graph lines along the paper feed (vertically). The value m is the number of lines and should be within the range 1 to the maximum number of dots per line (See Section 1.7)

In a horizontal dot line, there are m intersections of m curving graph lines. The value n1, n2, ... , nk represent the position of these m intersections. The number of nk must

equal m . Each n_k must fall within the maximum number of dots per line. The last CR (Carriage Return) lets printer print one dot line. As all horizontal lines are printed out with respective n_k values, m curves will appear in the printout.

Example:

To print out graph lines of the five equations:

$$Y_1 = 50 + 40 \cdot \exp(-0.01 \cdot X) \cdot \sin(X/10)$$

$$Y_2 = 50 - 40 \cdot \exp(-0.01 \cdot X) \cdot \sin(X/10)$$

$$Y_3 = 50$$

$$Y_4 = 50 + 40 \cdot \exp(-0.01 \cdot X)$$

$$Y_5 = 50 - 40 \cdot \exp(-0.01 \cdot X)$$

Program with BASIC language as below:

```
10 FOR X=0 TO 150      'print 150 dot lines
20 Y=INT(40*EXP(-0.01*X))
30 YY=INT(Y*SIN(X/10))
40 LPRINT CHR$(27)CHR$(39)CHR$(5);
                        'ESC' command m=5
50 LPRINT CHR$(50+YY)CHR$(50-YY)CHR$(50);
60 LPRINT CHR$(50+Y)CHR$(50-Y)CHR$(13);
70 NEXT X
```

Printout on TP μ P-A :

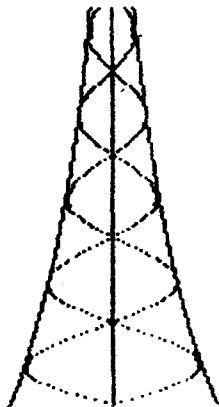

4.7 Initialization Command

ESC @ Initialize printer

Format: ASCII : ESC @
Decimal : 27 64
Hexadecimal : 1B 40

Explanation:

Reset printer to:

- * clear print buffer
- * restore default values
- * select Font 1
- * de-select user-defined characters

4.8 Data Control Commands

CR Carriage Return

Format: ASCII : CR
Decimal : 13
Hexadecimal : 0D

Explanation:

When a Carriage Return is sent to the printer, any data in the buffer is printed and paper is fed one line.

CAN Cancel line

Format: ASCII : CAN
Decimal : 24
Hexadecimal : 18

Explanation:

This command cancels all text in the print buffer preceding this code back to the previous Carriage Return. It does not cancel any control code sequences issued in that line.

DEL	Delete character
------------	------------------

Format: ASCII : DEL
Decimal : 127
Hexadecimal : 7F

Explanation:

The previous character in the buffer is deleted unless that character has already been printed. This command will not remove control codes.

NUL	Null
------------	------

Format: ASCII : NUL
Decimal : 0
Hexadecimal : 00

Explanation:

NUL is used as the final code in some commands such as ESC B, ESC D and ESC %.

NUL command is ignored by printer when used alone.

4.9 Hexadecimal Dump Printing Command

ESC "	Turn Hexadecimal Dump printing on/off
--------------	---------------------------------------

Format: ASCII : ESC " n
Decimal : 27 34 n
Hexadecimal : 1B 22 n

Explanation:

Hexadecimal Dump print mode is turned on if n=1, and turned off if n=0. If you execute programs or list program in Hexadecimal Dump print mode, all data sent from the host computer will be printed out in hexadecimal.

Example:

When the following 4 data are sent from the host computer after the command ESC ".

```
10 LPRINT CHR$(27);CHR$(34);CHR$(1);  
20 LPRINT CHR$(0);CHR$(27);"A";CHR$(24);
```

The printout reads:

```
00 1B 41 18
```

Printing in the Hexadecimal Dump mode is performed only when the printer is in the buffer-full state.

Chapter 5. Operating Note

1. Do not dismantle printer head.
2. Do not leave power on when not in use for a long period.
3. Switch off if printer works abnormally.
4. Power supply must match requirement. See Section 2.3.
5. Do not lubricate the printer head.
6. Fluff and dust from paper are harmful to printer head.
Check and clear the head when replacing paper roll.
7. When replacing ribbon, do not press the cassette too heavily. Otherwise the plastic wheel on the head may be damaged
7. Keep the main circuit board clean.
8. Do not remove the IC chips in the main board.
10. Never use ribbon oil. It may damage printer head.

Appendix A. Specifications

- * **Print Method:**
Impact dot matrix.
- * **Print Characters:**
448 defined characters, include all 96 ASCII characters, Greek, German, Russian, French, Japanese and Chinese characters; math symbols, printing symbols, block graphic characters, plus
32 user definable characters.
- * **Character Compositions:**
Standard characters: 5X7 dot matrix.
Block graphic characters: 6X8 dot matrix.
User definable characters: 6X8 dot matrix.
- * **Line Feed Pitch:**
1 - 255 dot lines.
- * **Interface:**
Parallel interface (CENTRONICS compatible).
Serial interface (RS-232C compatible).
- * **Interface Connector:**
Parallel interface: 26-pin ribbon cable socket.
Serial interface: DB-9 female socket.

* Interface Signals:

Parallel interface:

Pin 1:	data STroBe	(in)
Pin 3-17:	DB0-DB7	(in)
Pin 19:	ACKnowledge	(out)
Pin 21:	BUSY	(out)
Pin 25:	SElect	(out)
Pin 4:	ERRor	(out)

Serial interface:

Pin 1:	DCD	(out)
Pin 2:	RxD	(out)
Pin 3:	TxD	(in)
Pin 5:	GND	(---)
Pin 6:	DSR	(out)
Pin 8:	CTS	(out)

- * **Control Codes:**
36 codes ESC/P compatible.
- * **Input Buffer:**
0.5K bytes, expandable to 6.5K or 30.5K.
- * **Buttons:**
SEL SElect (On/Off Line)
LF Line Feed
- * **LED Indicators:**
Green LED, On/Off Line indicator.

- * Self-Test:
 - Press button SEL when Power On
 - Press buttons L.F & SEL when LED SEL off
- * DIP Switch: (for serial interface, built in)
 - Baud Rate selection: 19200, 9600, 4800, 2400, 1200, 600, 300, 150 bps
 - Parity selection: Even, Odd, or None.
 - Handshaking selection:
 - FLAG control
 - XON/XOFF protocol
 - Data bits selection:
 - 8 bits with Even, Odd or None Parity
 - 7 bits with Even Parity
- * Paper: Normal paper roll
 - Width: 44.5mm +/- 0.5mm for TP μ P-A16 or 57.5mm, +/- 0.5mm for other models
 - OD: <= 40 mm
- * Reliability:
 - MCBF 500,000 lines
- * Power:
 - DC 5V, Max. 1.5A
- * Dimension:
 - 111mm (W) X 62mm (H) X 128mm (D)
- * Weight:
 - 350 grams, with paper roll.
- * Environment :
 - 0°C to +40°C

Parameters of 6 Models of TP μ P-A Series

Model	Char./Line (5x7)	Char. Size (WxH mm)	Dot Size (WxH mm)	Dots/Line	Speed (Lines/Sec)	Interface
TP μ P-A16P	16	1.8x2.5	0.35x0.35	96	1.0	CENTRONICS
TP μ P-A16S						RS-232C
TP μ P-A24P	24	1.7x2.4	0.33x0.37	144	0.7	CENTRONICS
TP μ P-A24S						RS-232C
TP μ P-A40P	40	1.1x2.4	0.20x0.33	240	0.4	CENTRONICS
TP μ P-A40S						RS-232C

Appendix B. DIP Switch

There is a six-section DIP switch on the controller board. This is used to set the parameters of the serial port of TP μ P-AXXS. Three switches of the DIP switch are used to set the Baud Rate. One sets Handshaking. The remaining two switches set 8 bits or 7 bits each character as well as Parity Check.

The DIP switch was set ex-factory as:

Ex-factory Switch Setting

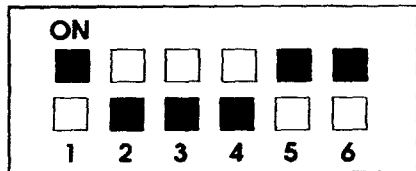

i.e. Baud Rate 9600 bps, Handshaking X-ON/X-OFF protocol, character 8 bits, and Parity Check Non-Parity.

DIP switch settings:

Baud Rate Setting

DIP SWITCH	BPS
ON <input checked="" type="checkbox"/> <input type="checkbox"/> <input type="checkbox"/> <input type="checkbox"/> <input type="checkbox"/> <input type="checkbox"/> 1 2 3 4 5 6	150
ON <input checked="" type="checkbox"/> <input type="checkbox"/> <input type="checkbox"/> <input type="checkbox"/> <input type="checkbox"/> <input type="checkbox"/> 1 2 3 4 5 6	300
ON <input type="checkbox"/> <input type="checkbox"/> <input type="checkbox"/> <input type="checkbox"/> <input type="checkbox"/> <input type="checkbox"/> <input checked="" type="checkbox"/> <input checked="" type="checkbox"/> <input type="checkbox"/> <input type="checkbox"/> <input type="checkbox"/> <input type="checkbox"/> 1 2 3 4 5 6	600
ON <input type="checkbox"/> <input type="checkbox"/> <input type="checkbox"/> <input type="checkbox"/> <input type="checkbox"/> <input type="checkbox"/> <input checked="" type="checkbox"/> <input checked="" type="checkbox"/> <input checked="" type="checkbox"/> <input type="checkbox"/> <input type="checkbox"/> <input type="checkbox"/> 1 2 3 4 5 6	1200
ON <input type="checkbox"/> <input type="checkbox"/> <input type="checkbox"/> <input type="checkbox"/> <input type="checkbox"/> <input type="checkbox"/> <input checked="" type="checkbox"/> <input checked="" type="checkbox"/> <input type="checkbox"/> <input type="checkbox"/> <input type="checkbox"/> <input type="checkbox"/> <input checked="" type="checkbox"/> <input checked="" type="checkbox"/> <input checked="" type="checkbox"/> <input checked="" type="checkbox"/> <input type="checkbox"/> <input type="checkbox"/> 1 2 3 4 5 6	2400
ON <input type="checkbox"/> <input type="checkbox"/> <input type="checkbox"/> <input type="checkbox"/> <input type="checkbox"/> <input type="checkbox"/> <input checked="" type="checkbox"/> <input checked="" type="checkbox"/> <input type="checkbox"/> <input type="checkbox"/> <input type="checkbox"/> <input type="checkbox"/> <input checked="" type="checkbox"/> <input checked="" type="checkbox"/> <input checked="" type="checkbox"/> <input checked="" type="checkbox"/> <input checked="" type="checkbox"/> <input type="checkbox"/> 1 2 3 4 5 6	4800
ON <input type="checkbox"/> <input type="checkbox"/> <input type="checkbox"/> <input type="checkbox"/> <input type="checkbox"/> <input type="checkbox"/> <input checked="" type="checkbox"/> <input checked="" type="checkbox"/> <input type="checkbox"/> <input type="checkbox"/> <input type="checkbox"/> <input type="checkbox"/> <input checked="" type="checkbox"/> <input checked="" type="checkbox"/> <input checked="" type="checkbox"/> <input checked="" type="checkbox"/> <input checked="" type="checkbox"/> <input checked="" type="checkbox"/> 1 2 3 4 5 6	9600
ON <input type="checkbox"/> <input type="checkbox"/> <input type="checkbox"/> <input type="checkbox"/> <input type="checkbox"/> <input type="checkbox"/> <input checked="" type="checkbox"/> <input checked="" type="checkbox"/> <input type="checkbox"/> <input type="checkbox"/> <input type="checkbox"/> <input type="checkbox"/> <input checked="" type="checkbox"/> <input checked="" type="checkbox"/> <input checked="" type="checkbox"/> <input checked="" type="checkbox"/> <input checked="" type="checkbox"/> <input checked="" type="checkbox"/> 1 2 3 4 5 6	19200

Handshaking Setting

DIP SWITCH	HANDSHAKING
ON <input type="checkbox"/> <input type="checkbox"/> <input checked="" type="checkbox"/> <input type="checkbox"/> <input type="checkbox"/> <input type="checkbox"/> <input type="checkbox"/> <input type="checkbox"/> <input type="checkbox"/> <input type="checkbox"/> <input type="checkbox"/> <input type="checkbox"/> 1 2 3 4 5 6	FLAG
ON <input type="checkbox"/> <input type="checkbox"/> <input type="checkbox"/> <input type="checkbox"/> <input type="checkbox"/> <input type="checkbox"/> <input type="checkbox"/> <input checked="" type="checkbox"/> <input type="checkbox"/> <input type="checkbox"/> <input type="checkbox"/> <input type="checkbox"/> 1 2 3 4 5 6	XON/XOFF

Parity Setting

DIP SWITCH	PARITY
ON <input type="checkbox"/> <input type="checkbox"/> <input type="checkbox"/> <input type="checkbox"/> <input checked="" type="checkbox"/> <input checked="" type="checkbox"/> <input type="checkbox"/> <input type="checkbox"/> <input type="checkbox"/> <input type="checkbox"/> <input type="checkbox"/> <input type="checkbox"/> 1 2 3 4 5 6	8-NON
ON <input type="checkbox"/> <input type="checkbox"/> <input type="checkbox"/> <input type="checkbox"/> <input checked="" type="checkbox"/> <input checked="" type="checkbox"/> <input type="checkbox"/> <input type="checkbox"/> <input type="checkbox"/> <input type="checkbox"/> <input checked="" type="checkbox"/> <input checked="" type="checkbox"/> 1 2 3 4 5 6	8-ODD
ON <input type="checkbox"/> <input type="checkbox"/> <input type="checkbox"/> <input type="checkbox"/> <input checked="" type="checkbox"/> <input checked="" type="checkbox"/> <input type="checkbox"/> <input type="checkbox"/> <input type="checkbox"/> <input type="checkbox"/> <input type="checkbox"/> <input checked="" type="checkbox"/> 1 2 3 4 5 6	8-EVEN
ON <input type="checkbox"/> <input type="checkbox"/> <input type="checkbox"/> <input type="checkbox"/> <input type="checkbox"/> <input type="checkbox"/> <input checked="" type="checkbox"/> <input checked="" type="checkbox"/> <input type="checkbox"/> <input type="checkbox"/> <input type="checkbox"/> <input type="checkbox"/> <input checked="" type="checkbox"/> <input checked="" type="checkbox"/> <input checked="" type="checkbox"/> <input checked="" type="checkbox"/> <input type="checkbox"/> <input type="checkbox"/> 1 2 3 4 5 6	7-EVEN

Appendix C. Character Code Tables

There are two character code tables or sets in the printer.
Code Range from 20H (Hexadecimal) to FFH (Hexadecimal).

Font 1:

	0	1	2	3	4	5	6	7	8	9	A	B	C	D	E	F
2	!	"	#	\$	%	&	'	<	>	*	+	,	-	.	/	
3	0	1	2	3	4	5	6	7	8	9	:	;	<	=	>	?
4	@	A	B	C	D	E	F	G	H	I	J	K	L	M	N	O
5	P	Q	R	S	T	U	V	W	X	Y	Z	[\]	^	_
6	`	a	b	c	d	e	f	g	h	i	j	k	l	m	n	o
7	p	q	r	s	t	u	v	w	x	y	z	()	~		
8	9	ü	é	ä	ä	ä	9	ø	é	é	î	î	ä	ä		
9	é	æ	é	ö	ö	ü	ü	ÿ	ö	ö	€	€	€	€	€	€
A	ä	ä	ö	ü	ü	ü	ü	ü	ü	ü	ü	ü	ü	ü	ü	ü
B	ü	ü	ü	ü	ü	ü	ü	ü	ü	ü	ü	ü	ü	ü	ü	ü
C	L	L	T	T	T	T	T	T	T	T	T	T	T	T	T	T
D	ä	ä	ä	ä	ä	ä	ä	ä	ä	ä	ä	ä	ä	ä	ä	ä
E	ä	ä	ä	ä	ä	ä	ä	ä	ä	ä	ä	ä	ä	ä	ä	ä
F	ä	ä	ä	ä	ä	ä	ä	ä	ä	ä	ä	ä	ä	ä	ä	ä

Code 00H to 1FH are control codes (See Appendix E).
ESC 6 command is used to select Font 1, and ESC 7 to
select Font 2.

Font 2:

	0	1	2	3	4	5	6	7	8	9	A	B	C	D	E	F
2	-	二	三	四	五	六	七	八	九	十	百	千	万	元	角	分
3	■	ア	イ	ウ	エ	オ	カ	キ	ク	ケ	コ	ク	シ	ス	セ	ソ
4	サ	チ	ツ	テ	ト	ナ	ニ	ホ	ヘ	フ	ノ	ハ	ヒ	フ	ヘ	マ
5	キ	ク	ケ	コ	カ	キ	ク	ケ	コ	カ	キ	ク	ケ	コ	カ	キ
6	ン	ア	カ	キ	ク	ケ	コ	カ	キ	ク	ケ	コ	カ	キ	ク	ケ
7	ハ	ヒ	フ	ヘ	マ	メ	ム	ミ	モ	ム	ミ	モ	ム	ミ	モ	ム
8	ヤ	ユ	ヨ	ヤ	ユ	ヨ	ヤ	ユ	ヨ	ヤ	ユ	ヨ	ヤ	ユ	ヨ	ヤ
9	ヨ	ヨ	ヨ	ヨ	ヨ	ヨ	ヨ	ヨ	ヨ	ヨ	ヨ	ヨ	ヨ	ヨ	ヨ	ヨ
A	1	2	3	4	5	6	7	8	9	0	1	2	3	4	5	6
B	□	□	□	□	□	□	□	□	□	□	□	□	□	□	□	□
C	□	□	□	□	□	□	□	□	□	□	□	□	□	□	□	□
D	△	△	△	△	△	△	△	△	△	△	△	△	△	△	△	△
E	○	○	○	○	○	○	○	○	○	○	○	○	○	○	○	○
F	..	()	ア	イ	ウ	エ	オ	カ	キ	ク	ケ	コ	カ	キ	ク

VER. 3.3A-168
9600bps, N,8,1
RS-232 INTERFACE

Selftest OK!
TPMP

TPMP 025
* * * * *
A L T - 1 2 3 4 5 6 7 8 9 0
[] \ / # % & ' () * + , - . : ;
! " # \$ % & ' () * + , - . : ;
@ A B C D E F G H I J K L M N O
P Q R S T U V W X Y Z [\] ^ _ ` a b c d e f g
h i j k l m n o p q r s t u v w x y z { | } ~
! " # \$ % & ' () * + , - . / 0 1 2 3 4 5 6 7

* * * * *
@ A B C D E F G H I J K L M N O
P Q R S T U V W X Y Z [\] ^ _ ` a b c d e f g
h i j k l m n o p q r s t u v w x y z { | } ~
! " # \$ % & ' () * + , - . / 0 1 2 3 4 5 6 7
8 9 : ; < = > ? @ A B C D E F G H I J K L M N O
! " # \$ % & ' () * + , - . / 0 1 2 3 4 5 6 7

Fig. D-3. Self-Test sample of TP μ P-A24S

VER. 3.3A-168
CENTRONICS INTERFACE

Selftest OK!
TPMP

TPMP 025
* * * * *
A L T - 1 2 3 4 5 6 7 8 9 0
[] \ / # % & ' () * + , - . : ;
! " # \$ % & ' () * + , - . : ;
@ A B C D E F G H I J K L M N O
P Q R S T U V W X Y Z [\] ^ _ ` a b c d e f g
h i j k l m n o p q r s t u v w x y z { | } ~
! " # \$ % & ' () * + , - . / 0 1 2 3 4 5 6 7

* * * * *
@ A B C D E F G H I J K L M N O
P Q R S T U V W X Y Z [\] ^ _ ` a b c d e f g
h i j k l m n o p q r s t u v w x y z { | } ~
! " # \$ % & ' () * + , - . / 0 1 2 3 4 5 6 7
8 9 : ; < = > ? @ A B C D E F G H I J K L M N O
! " # \$ % & ' () * + , - . / 0 1 2 3 4 5 6 7

Fig. D-4. Self-Test sample of TP μ P-A24P

Selftest OK!
TPMP

Selftest OK!
TPMP

Fig. D-5. Self-Test sample of TP μP-A40S

Selftest OK!
TPMP

Selftest OK!
TPMP

Fig. D-6. Self-Test sample of TP μP-A40P

Appendix E. Printing Command Codes

Decimal	Hex.	Symbol Format	Function	Page
0	00	NUL	Ending signal-----	37
9	09	HT	Horizontal tab-----	23
10	0A	LF	Line Feed-----	19
11	0B	VT	Vertical tab-----	22
12	0C	FF	Form Feed-----	20
13	0D	CR	Carriage Return-----	36
14	0E	SO	Double-width print-----	29
20	14	DC4	Cancel SO command-----	29
24	18	CAN	Delete line-----	36
27 34	1B 22	ESC " n	Hexadecimal Dump print-----	37
27 37	1B 25	ESC % m1 n1 ... NUL	Replace with user-defined characters-----	31
27 38	1B 26	ESC & m n1 ... n6	Define user-defined character-----	30
27 39	1B 27	ESC ' m n1 ... nk CR	Print curving graph lines-----	34
27 43	1B 2B	ESC+ n	Overscore-----	28
27 45	1B 2D	ESC - n	Underline-----	27
27 49	1B 31	ESC 1 n	Set line spacing-----	19
27 54	1B 36	ESC 6	Select Font 1-----	28
27 55	1B 37	ESC 7	Select Font 2-----	28
27 58	1B 3A	ESC :	Reinstate character in ROM-----	32
27 64	1B 40	ESC @	Initialize printer-----	36

Appendix E. Printing Command Codes - Continued

Decimal	Hex.	Symbol Format	Function	Page
27 66	1B 42	ESC B n1 n2 ... NUL	Set vertical tabs-----	21
27 67	1B 43	ESC C n	Set page length-----	20
27 68	1B 44	ESC D n1 n2 ... NUL	Set horizontal tabs-----	22
27 74	1B 4A	ESC J n	Paper Feed-----	19
27 75	1B 4B	ESC K n1 n2 .data.	Bit Image printing-----	32
27 78	1B 4E	ESC N n	Set bottom margin-----	20
27 79	1B 4F	ESC O	Cancel bottom margin-----	21
27 81	1B 51	ESC Q n	Set right margin-----	24
27 85	1B 55	ESC U n	Enlarge in width-----	25
27 86	1B 56	ESC V n	Enlarge in height-----	26
27 87	1B 57	ESC W n	Enlarge in width & height-----	27
27 99	1B 63	ESC c n	Inverse printing-----	30
27 102	1B 66	ESC f m n	Print blank character or blank line-----	23
27 105	1B 69	ESC i n	Reverse printing (white in black)-----	29
27 108	1B 6C	ESC l n	Set left margin-----	25
127	7F	DEL	Delete last character-----	37

Appendix F. Parallel Interface and Operation

1. Parallel Interface Signals

Pin No.	Signal	In/Out	Description
1	STB	IN	Strobe pulse to read data in
3	DATA1	IN	These signals represent information of the 1st to 8th bits of parallel data respectively. Each signal is at "HIGH" level when data is logical "1" and "LOW" when logical "0"
5	DATA2	IN	
7	DATA3	IN	
9	DATA4	IN	
11	DATA5	IN	
13	DATA6	IN	
15	DATA7	IN	
17	DATA8	IN	
19	ACK	OUT	Acknowledge pulse. "LOW" indicates that data has been received and that the printer is ready to accept next data
21	BUSY	OUT	Signal set "HIGH" to indicate the printer cannot accept data
23	PE	Pull-down to ground
25	SEL	OUT	Pull-up to +5V through 3.3k resistor, to indicate the printer in ON-LINE
4	ERROR	OUT	Pull-up to +5V through 3.3k resistor
2, 6, 8, 26	NC	No connection
10-24	GND	Ground, Logical "0" level

2. Parallel Interface Operation

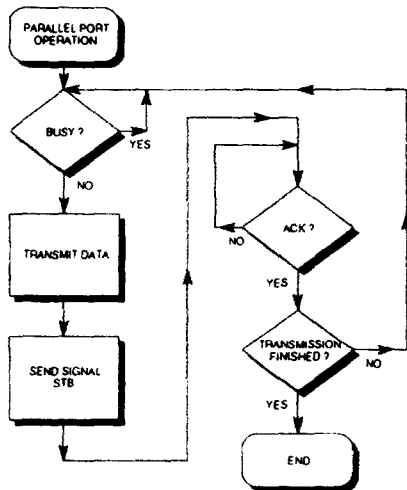

Appendix G. Serial Interface and Operation

1. Serial Interface Signals

Pin No.	Signal	Source	Description
1	DCD	Printer	Same as CTS
2	RxD	Printer	Printer transmits data when uses the hand-shaking of X-ON/X-OFF
3	TxD	Host	Printer receives data from host computer
5	GND		Signal ground
6	DSR	Printer	Signal set "SPACE" to indicate the printer is ON-LINE
8	CTS	Printer	Signal set "MARK" state to indicate the printer is BUSY and can not accept data, and "SPACE" state to indicate the printer is ready and can accept data

2. Serial Interface Operation

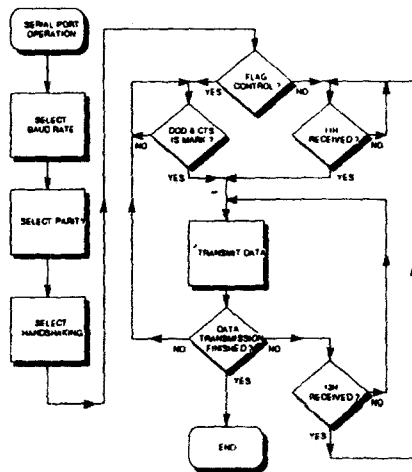

Appendix H. Option List

1. Ribbon Cassette

- A. EPSON ERC-05, for TP μ P-A16.**
- B. EPSON ERC-09, for TP μ P-A24 or TP μ P-A40.**

2. Paper Roll

- A. Width 44.5 \pm 0.5mm, Thickness 0.07mm**
Outer Diameter less than 40mm, for TP μ P-A16.
- B. Width 57.5 \pm 0.5mm, Thickness 0.07mm**
Outer Diameter less than 40mm, for TP μ P-A24 or
TP μ P-A40

3. Cable

- for separate installation of Chassis and Controller.**
- A. TP CABUPA-01, 11 way flat cable, length 25cm,**
for link between Printer Head and Controller.
- B. TP CABUPA-02, 5 way cable, length 25cm,**
for link between Keyboard and Controller.

Appendix I. Printer Outline

Unit: mm

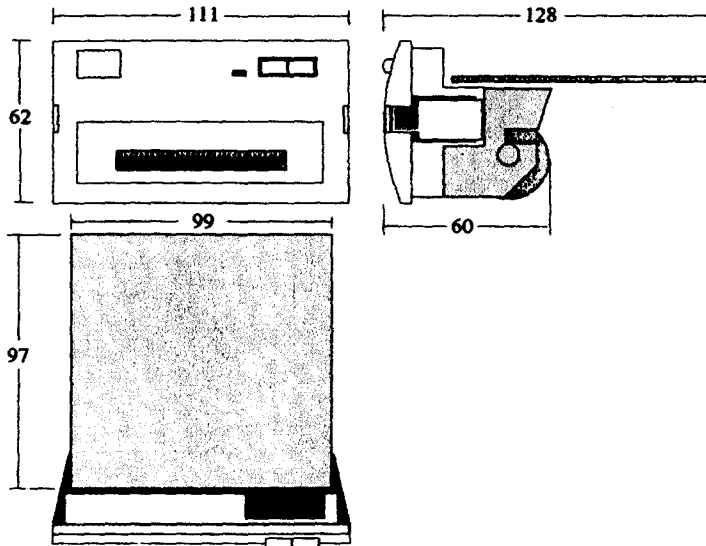

Notes: